

# MAGNETIC CONTACTORS AND STARTERS

# SOLID-STATE CONTACTORS

## INDIVIDUAL CATALOG

from D&C CATALOG 19th Edition  
Revised

# 01

Magnetic contactors  
SC series



Solid-state contactors



Magnetic motor starters  
SW series



Solid-state contactors



Reversing motor starters  
SW series



Thermal overload relays



Magnetic contactors  
FC series



**LOW  
VOLTAGE  
EQUIPMENT  
Up to 600 Volts**

## D & C CATALOG DIGEST INDEX

---

Individual catalog No.	LOW VOLTAGE PRODUCTS Up to 600 Volts
------------------------	--------------------------------------

---

<b>01</b>	Magnetic Contactors and Starters Thermal Overload Relays, Solid-state Contactors
-----------	---

---

<b>02</b>	DUO series Manual Motor Starters and Contactors Combination Starters
-----------	--

---

<b>03</b>	Industrial Relays, Industrial Control Relays Annunciator Relay Unit, Time Delay Relays Electronic Counters
-----------	--

---

<b>04</b>	Pushbuttons, Selector Switches, Pilot Lights Rotary Switches, Cam Type Selector Switches Panel Switches, Terminal Blocks, Testing Terminals
-----------	---

---

<b>05</b>	AS-Interface, Limit Switches Proximity Switches Photoelectric Switches
-----------	--

---

<b>06</b>	Molded Case Circuit Breakers
-----------	------------------------------

---

<b>07</b>	Earth Leakage Circuit Breakers Earth Leakage Protective Relays
-----------	---

---

<b>08</b>	Circuit Protectors Low Voltage Current-Limiting Fuses Air Circuit Breakers
-----------	--

---

<b>09</b>	Measuring Instruments, Arresters, Transducers Power Factor Controllers Power Monitoring Equipment (F-MPC)
-----------	---

---

<b>10</b>	AC Power Regulators Noise Suppression Filters Control Power Transformers
-----------	--

---

### HIGH VOLTAGE PRODUCTS Up to 36kV

---

<b>11</b>	Disconnecting Switches, Power Fuses Air Load Break Switches Instrument Transformers — VT, CT
-----------	--

---

<b>12</b>	Vacuum Circuit Breakers, Vacuum Magnetic Contactors Protective Relays
-----------	--

---

# 01

## Magnetic Contactors and Starters Solid-state Contactors

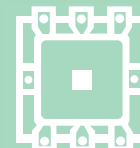

	Page
<b>Magnetic Contactors and Starters</b>	SC and SW series standard type
	General information ..... 01/1
	Design feature ..... 01/2
	Versions ..... 01/10
	Quick selection guide
	Non reversing, Open type ..... 01/12
	Enclosed type ..... 01/17
	Reversing, Open type ..... 01/20
	Enclosed type ..... 01/23
	Type number nomenclature ..... 01/25
	Ordering code system ..... 01/26
	Specifications ..... 01/28
	Standard type ..... 01/33
	Reversing standard type ..... 01/42
	DC operated ..... 01/49
	OFF-delay release ..... 01/54
	With extra pick-up operating coil ..... 01/55
	Mechanical latch contactors ..... 01/56
	Heavy starting duty starters ..... 01/61
	With quick operating overload relay ..... 01/63
	With phase loss protective device ..... 01/64
	With phase loss and phase-sequence protective device ..... 01/66
	Enclosed with pushbuttons ..... 01/68
	Dust-tight/light-corrosion resistance ..... 01/70
	For single-phase resistance load ..... 01/71
	With single button auxiliary contact ..... 01/72
	With quick connection terminals ..... 01/73
	Optional unit ..... 01/74
<b>DC Magnetic Contactors</b>	SB series ..... 01/87
<b>Magnetic Contactors and Starters</b>	FC and FW series
	FC series ..... 01/90
	Ordering code system ..... 01/91
	FW series ..... 01/93
	FW series with pushbuttons ..... 01/96
<b>Thermal Overload Relays</b>	TR series
	General information ..... 01/97
	Ordering code system ..... 01/98
	Features and optional accessories ..... 01/99
	Selection guide
	Standard type ..... 01/100
	Long time operating type ..... 01/101
	Quick operating type ..... 01/102
	TK series
	With phase loss protective device ..... 01/109
<b>Solid-state Contactors</b>	SS series ..... 01/110
<b>Magnetic Contactors and Starters</b>	UL and CSA approved ..... 01/129
	TÜV approved ..... 01/136
	CCC approved ..... 01/140
	SJ series ..... 01/143

## **MINIMUM ORDERS**

Orders amounting to **less than ¥10,000** net per order will be charged as ¥10,000 net per order plus freight and other charges.

## **WEIGHTS AND DIMENSIONS**

Weights and dimensions appearing in this catalog are the best information available at the time of going to press.

FUJI ELECTRIC FA has a policy of continuous product improvement, and design changes may make this information out of date.

Please confirm such details before planning actual construction.

**INFORMATION IN THIS CATALOG IS SUBJECT TO CHANGE WITHOUT NOTICE.**

FUJI low-voltage contactors and starters are available in a broad choice of types, from high-performance to economy, for all consumer and industrial needs. For standard applications, we offer the high-performance SC series. We offer the economical F series for light industrial use, the SB series dedicated to DC circuits, and the SS series with long service-life noise-free solid-state contactors.

**SC and SW series**  
**Standard type magnetic contactors and starters**

The SC series is a range of long service-life and high-performance contactors. SC-03 to SC-N3 small-frame contactors provide snap-on fitting of numerous optional units, such as auxiliary contact blocks, coil surge suppressors, and operation counters. Field modifications are quick and easy to make.

Type SC-N5 and above contactors come with an IC-controlled SUPER MAGNET coil, which operates from both AC and DC sources, to eliminate burnt coils and contact chattering caused by voltage fluctuation.

**SB series**  
**DC magnetic contactors**

We developed the SB series DC contactors from our SC series AC contactors. Applications include opening and closing DC circuits and controlling DC motors. They permit switching of DC loads up to 550V DC, 360A. There are two main contact arrangements available: the 2NO type and the 2NO + 1NC type, which has one NC contact for dynamic brake circuits. Type SB-5N and above contactors come with an IC-controlled SUPER MAGNET coil for improved operational stability.

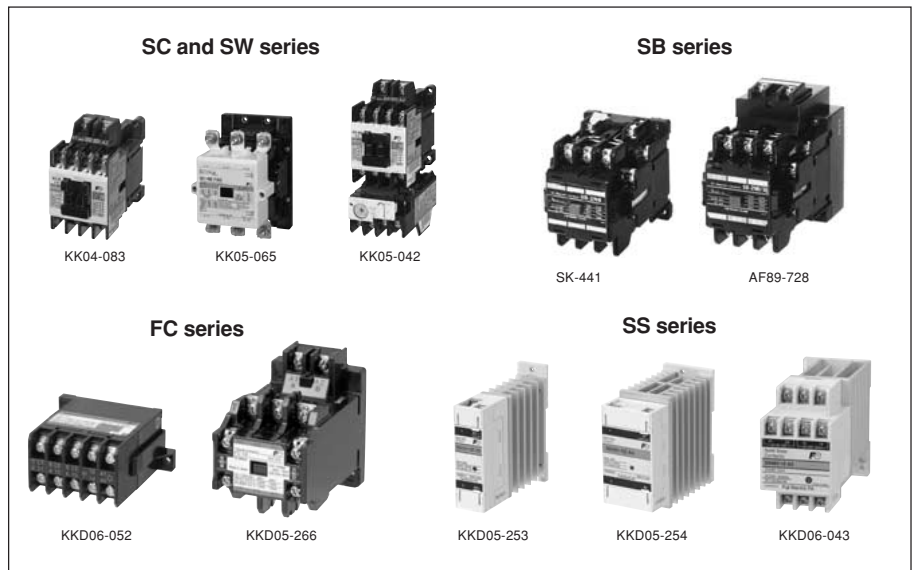

**FC and FW series**  
**Definite purpose contactors and starters**

The FC series contactors are compact and economical contactors designed for use in consumer appliances with relatively low switching frequencies. Typical applications include air conditioners, industrial washing machines, heaters, compressors, driers, and fans. Contactor pickup voltage is 75% of the rated voltage. FC-0 is available with tab and printed board terminals, as well as with self-lifting screw terminals.

**SS series**  
**Solid-state contactors**

The SS series contactors employ a semiconductor that can withstand both high voltage and large overcurrent when making and breaking load circuits. The completely contactless design gives high performance, including long service life and noise-free operation. Applications include frequent making and breaking for motors, heaters, and similar circuits. A built-in surge absorbing varistor and CR circuit to protect the SSC from surges when switching inductive loads, and surges from external circuits.

**DUO series**  
**BM3 series manual motor starters, SC-M and SC-E series magnetic contactors**

Refer to the Individual Catalog No.02.

# Magnetic Contactors and Starters

## SC and SW series

### Design features

**SC-03, 0, 05, 4-0, 4-1, 5-1**  
**SC-N1, N2, N2S, N3**

#### ■ Description

Small frame contactors with new functions join the SC series. The SC line up, which is based on high level technology, now extends from the SC-03 to the SC-N16. The SC series contactors have such options as additional auxiliary contact blocks and operation counter unit with snap-on fittings, and coil surge suppressors. Modification can be made quickly and easily on site.

Improved contact materials and structure double the electrical life compared with existing contactors —2 million operations. Bifurcated type auxiliary contacts have a high degree of contact reliability. Therefore, they can be used in low-level circuits of 5V, 3mA and directly input to electronic equipment.

Long electrical life  
 2 million operations (AC-3 duty)

Easy-to-read front display  
 Type, ratings and terminal numbers

Manual operator for easy circuit checking  
 ON-OFF status indicator

Direct-fitted overload relay assures time-saving assembly

Manual reset button

Dial cover for protection against unauthorized current setting

Single-side-mounted coil terminal  
 The coil surge suppressor or coil drive unit can be easily added

Terminal numbers meet IEC standards

Meets international standards  
 IEC, NEMA, BS, JIS, VDE  
 UL, CSA, NK, BV and LR approved

Bifurcated auxiliary contact with high contact reliability

Optional function unit can be easily added to modify contactor immediately on site.

- Auxiliary contact block fits all size contactors(03 to N3)
- Snap-on mechanical interlock unit can be fixed to equal or unequal size contactors without tools.
- Front-mounted operation counter

Exact current setting possible

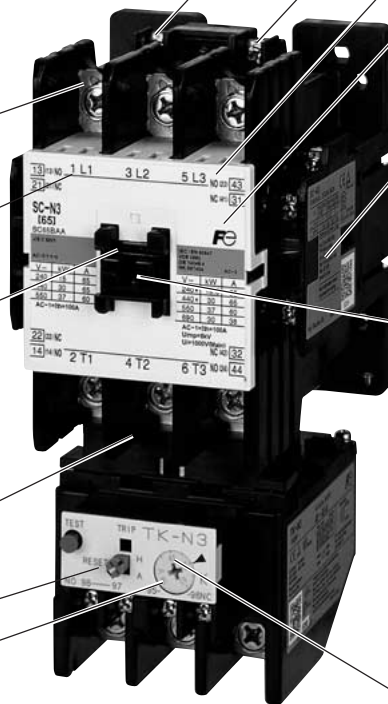

■ **Easy modular system**

- **Side mounting**  
 Auxiliary contact block  
 Single pole (1NO + 1NC)

**Mechanical interlock unit**  
 The mechanical interlock unit is used to interlock two contactors for reversing. One size fits all contactors.

**Main circuit surge suppression unit**  
 This unit prevents miss-operation of electronic controllers due to motor surge voltages.

- **Top mounting**  
**Coil drive unit**  
 This unit controls ON-OFF operation for magnetic contactors with output from electronic equipment.
- **Coil surge suppression unit**  
 This unit absorbs coil surge voltage due to contactor ON-OFF operations.

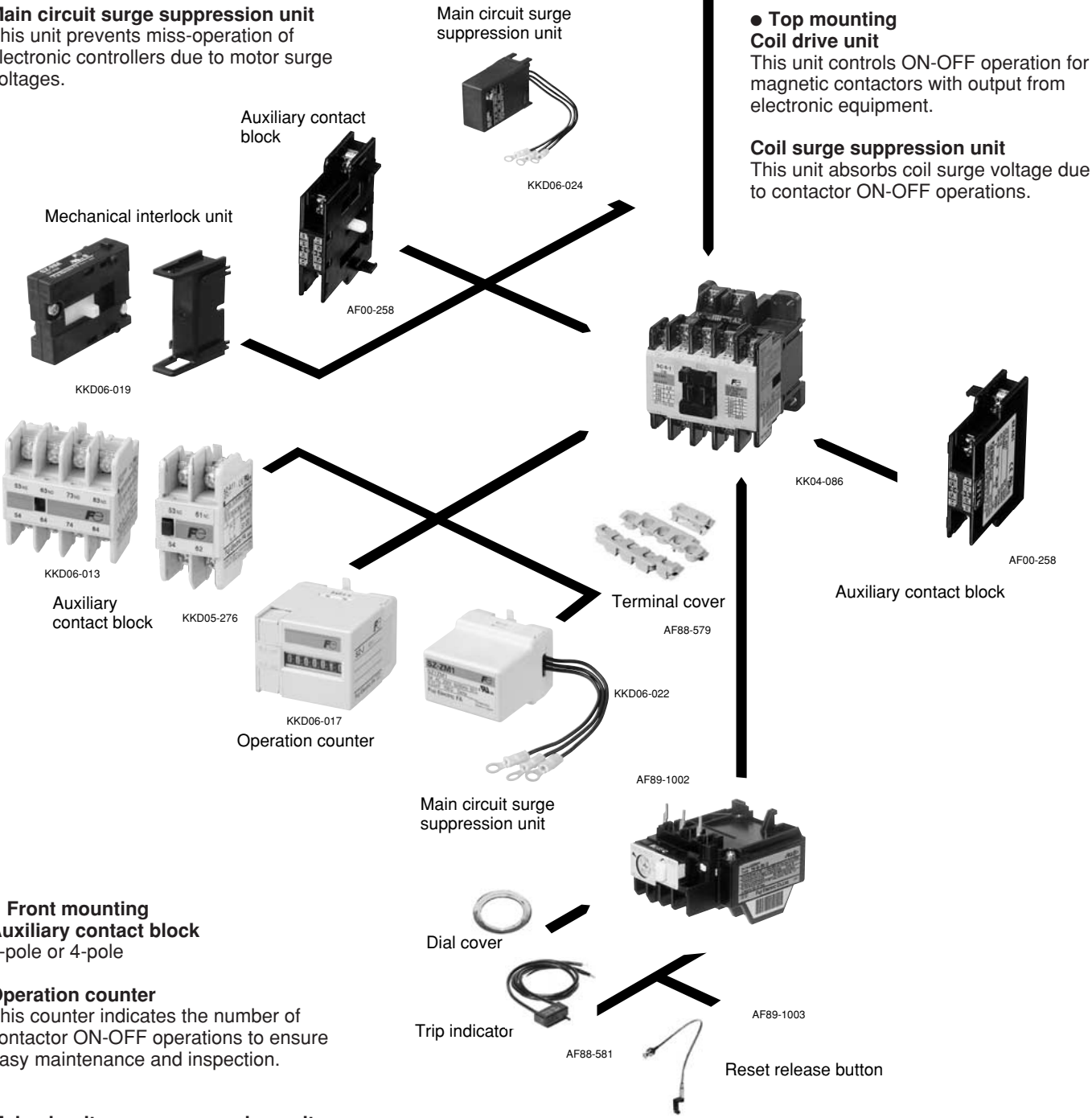

- **Front mounting**  
**Auxiliary contact block**  
 2-pole or 4-pole

**Operation counter**  
 This counter indicates the number of contactor ON-OFF operations to ensure easy maintenance and inspection.

**Main circuit surge suppression unit**

■ **Further information**  
[See page 01/75](#)

# Magnetic Contactors and Starters

## SC and SW series

### Design features

#### SC-N1 to N16

##### ■ Description

FUJI SC series (SC-N5 to N16) contactors have been developed and manufactured using FUJI's most advanced electronic technologies. They employ an electronically-controlled SUPER MAGNET which is provided with a built-in IC, thus enhancing their performance and reliability. The SUPER MAGNET is based on an "AC-input, DC-operated concept", thus allowing the coil to be energized by both AC and DC input. Moreover, once closed, sealed current is controlled by switching circuit. This permits a great reduction in power consumption – a cost-effective feature. The SC-N1 to SC-N4 are without SUPER MAGNET. These contactors feature compact size, arc extinguishing mechanisms having a high breaking efficiency, low power consumption, operational ease and ratings up to 660 volts.

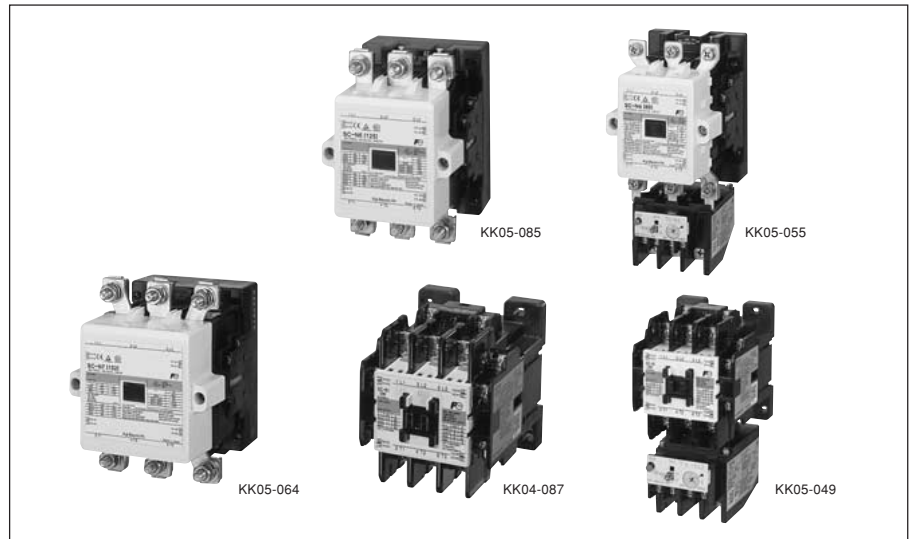

##### ■ Features of the SUPER MAGNET

- Operates on both AC and DC power supply
  - Has a wide operational voltage range
  - No tendency to "chatter"
  - Eliminates contact welding or coil burning
  - Reduces power consumption
- In addition the FUJI SC-N series contactors employ bifurcated auxiliary

contacts which improve contact performance and permit them to be used in conjunction with programmable logic controllers. FUJI SC-N series contactors are the most suitable for new FA age applications which require the most advanced electronic technologies and maximum dependability.

■ The FUJI SC series conforms to and has been approved by various international standards.

Specifications			Contactors		Starters(open)	
			Non-reversing	reversing	Non-reversing	reversing
No. of thermal overload relay heater elements			-	-	3	3
Type			SC-□	SC-□RM	SW-□/3H	SW-□RM/3H
Conformed	New JIS	Japan	○	○	○	○
	IEC	International	○	○	○	○
	BS	UK	○	○	○	○
	EN	Europe	○	○	○	○
Approved	UL	USA	○	○	○	○
	CSA	Canada	○	○	○	○
	CCC	China	○ *	○ *	-	-
EC Directives	CE Marking	Europe	○	○	○	○
Inspection Institute	TÜV	Germany	○	○	○	○

Notes ○ : Conforming to Standard

UL<sub>us</sub> : A new certification mark that indicates compliance with both Canadian and U.S. requirements.

□ : Frame size N1 to N14 and N16(Contact only)

\* : When ordering the ccc standard type, add(ccc)suffix to the type number.



■ **Advantages of SUPER MAGNET**

● **Positive pick-up and drop-out**

The SUPER MAGNET operation is electronically controlled. There is no unstable zone as will be seen in the diagram—an outstanding feature that other contactors can not provide. Chattering is a phenomenon which occurs when the gravitational force of the starter magnet decreases through the line voltage drop at the time of motor starting. This may cause damage such as contact welding or coil burning.

The SUPER MAGNET holds without chattering even if the line voltage drops to 65% of its rated value, so preventing this type of trouble.

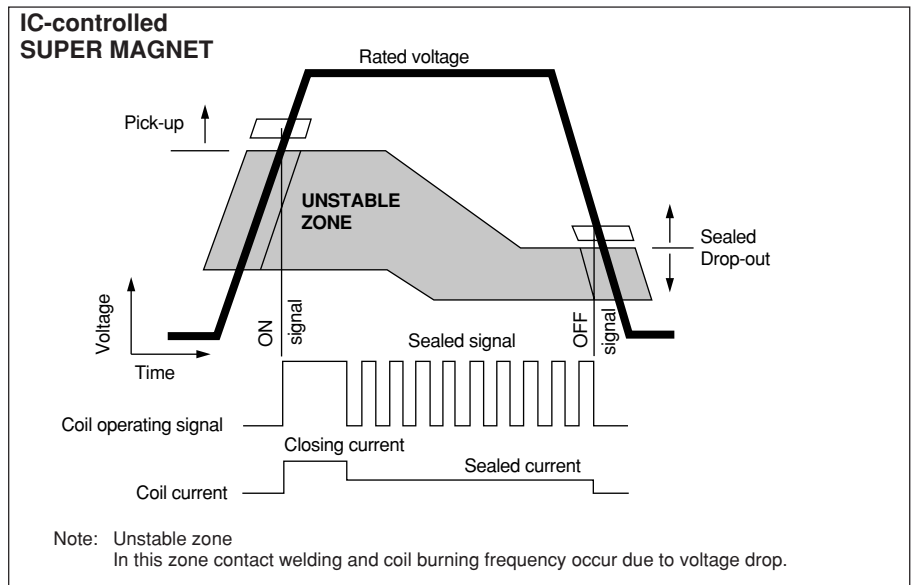

**Motor starting**

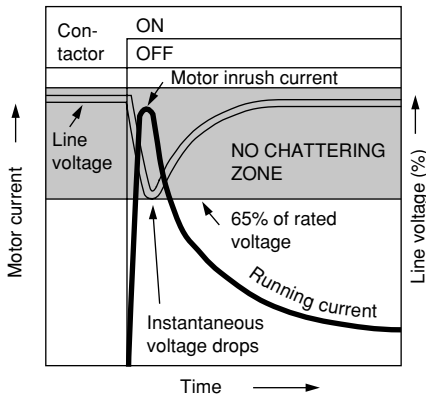

Note: No chattering occurs even if instantaneous voltage drops to 65% of rated voltage.

**Existing series**

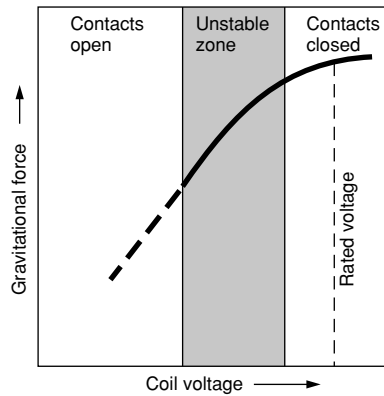

**SC-N series**

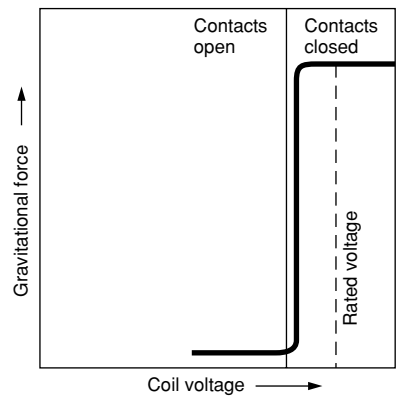

Note: Since SC series contactors are electronically controlled there is no unstable zone.

● **Operation on both AC and DC inputs**

The rated operational voltage range of the SC-N series contactors has been greatly expanded. They operate on both AC (50/60Hz) and DC inputs.

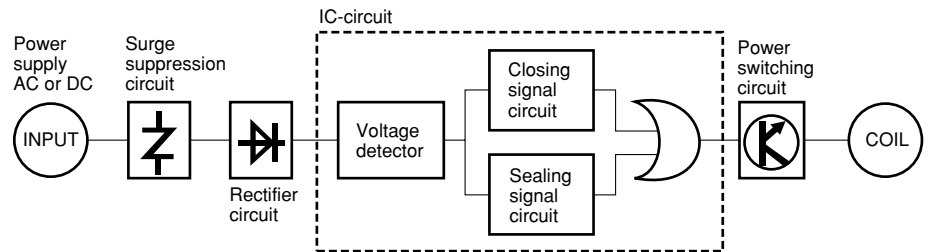

**Coils (SC-N5 to SC-N16)**

Rated voltage	Rated coil voltage, frequency	
	AC	DC
24V	24-25V 50/60 Hz	24V
48V	48-50V 50/60 Hz	48V
100V	100-127V 50/60 Hz	100-120V *1
200V	200-250V 50/60 Hz	200-240V *2
300V	265-347V 50/60 Hz	-
400V	380-450V 50/60 Hz	-
500V	460-575V 50/60 Hz	-

Notes: SC-N5 to N12: 24V-575V  
 SC-N14 to N16: 100V-575V

\*1: The coil voltage from a DC power supply with single phase full-wave rectification will be 100 to 110 V.

\*2: The coil voltage from a DC power supply with single phase full-wave rectification will be 200 to 220 V.

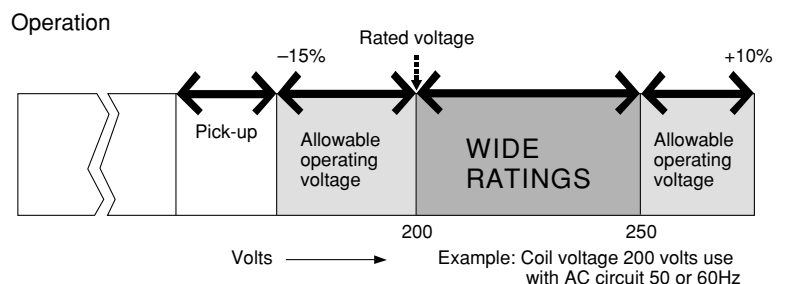

For further information, see page 01/30.

# Magnetic Contactors and Starters

## SC and SW series

### Design features

#### ■ Other advantages

##### ● Terminal cover for finger protection

These optional terminal covers comply with VBG4 (German Rules of Accident Prevention), IEC60529, DIN57106, VDE0106 Teil100, which are recommendations for preventing exposure to live parts. The terminal cover satisfies the requirements of Machinery Directive EN60204-1 "Direct Contact Prevention" concerning mechanical safety.

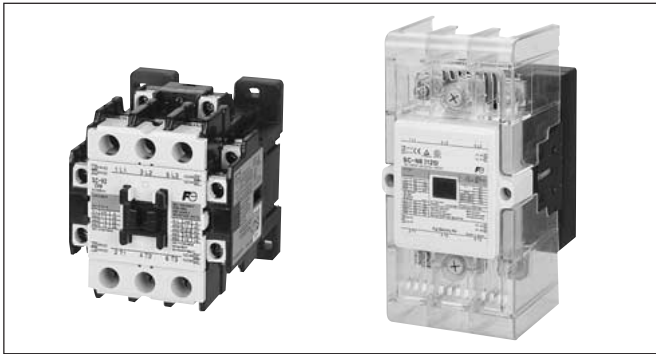

##### ● Insulation barrier

These optional insulation barriers prevent accidental short-circuits caused by metallic objects falling onto the terminals.



##### ● Live-section cover

An optional live-section cover that completely encloses the front of a contactor or starter for increased worker safety during maintenance and inspection.



##### ● Insulation

##### Improved tracking resistance

Tracking resistance of the molded parts comprising of the conductive block has been improved.

Comparative Tracking Index (CTI) : 175V or higher

Tracking : It means the route of the leak electric current caused on the surface of the isolation body.

##### ● Standard heat-proof material

The molded parts used are made of heat-proof materials specified in UL94

(UL94 : STANDARD FOR SAFETY FOR TESTS FOR FLAMMABILITY OF PLASTIC MATERIALS FOR PARTS IN DEVICES AND APPLIANCES).

##### ● Free arc space

A new arc-extinguishing method, which makes full use of magnetic field analysis technology, and a new material (UL94V-0) that has been incorporated into the design of this new type of arc-extinguishing chamber to provide a free arc space. This new method and design reduces the depth size, not only of the main body, but also that of the board (Types SC-N1 to N12).

Free arc space : It means arc space is not needed on making and breaking condition according to IEC 60947-4-1. (Refer to chart Arcing gas cooling block.)

##### Arc driving system (explanation only)

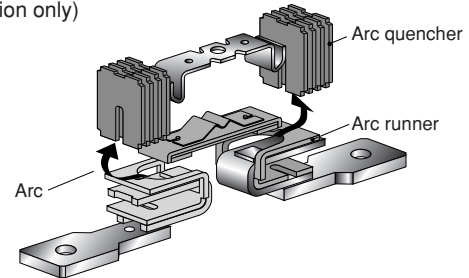

##### Arc gas cooling system (explanation only)

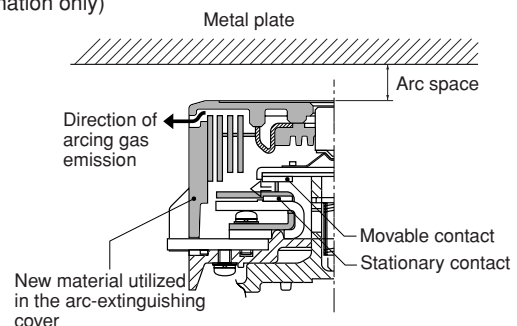

##### ● Mirror contacts (Positively safety contacts)

The contactor with mirror contacts has been certified by TÜV.

Mirror contact conforms to the requirement for auxiliary contact that is intended to be included in the future amendment to IEC 60947-4-1.

Mirror contact : Normally closed auxiliary contact, which cannot be in closed position simultaneously with the normally open main contact.

● **SUPER MAGNET with higher service reliability**

Employing a electronically controlled SUPER MAGNET(AC input DC operated) with an IC on its operating circuit, allows the FUJI SC series contactor to achieve higher service reliability.

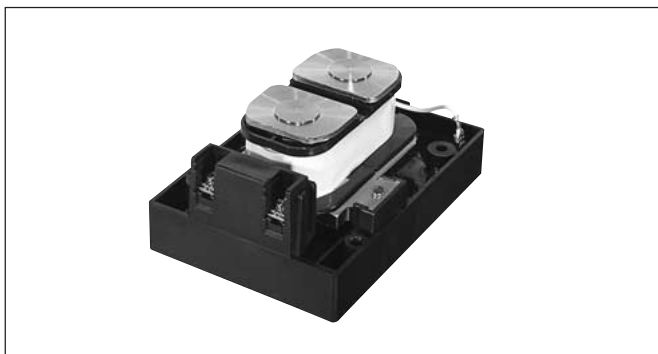

- There is no unstable zone as seen in the diagram on [page 01/5](#). The SUPER MAGNET holds without chattering which may cause damage such as contact welding or coil burning.
- Since normal rated voltage is applied when power is on, the contactor may be used without failure, even if the line voltage drops to 65% of the rated value when the main contacts are closed.
- The motor is prevented from starting if there is insufficient voltage.
- The power consumption and operating VA for the operating coil have been largely reduced.
- The rating range of the coil has been widened, and it may even be used as an AC/DC coil.
- A surge suppression function has been incorporated.
- Comforming to EMC.

● **Ambient operating temperature improved to 55°C**

The allowable ambient operating temperature was raised up to 55°C, considering the use on more compact control board and the higher mounting density.

● **Rail mounting**

Types SC-N1 to-N3, TR-N2H and -N3H incorporate snap-on mounting on 35mm-wide rails (conforming to IEC and DIN Standards).

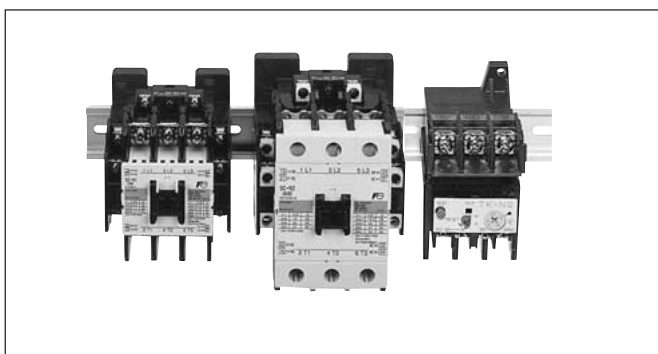

● **Bifurcated auxiliary contact system**

By employing a bifurcated contact system, higher contact reliability is achieved for service at 5V DC, 3mA (Types SC-N1 to N12).

● **Special type "/G" for DC operation added to SC-N1 to N3 series**

A new type of "/G" has been added to SC-N1 to N3 types for DC operation.

Power input and consumption have been considerably reduced by introducing a full voltage-applying coil.

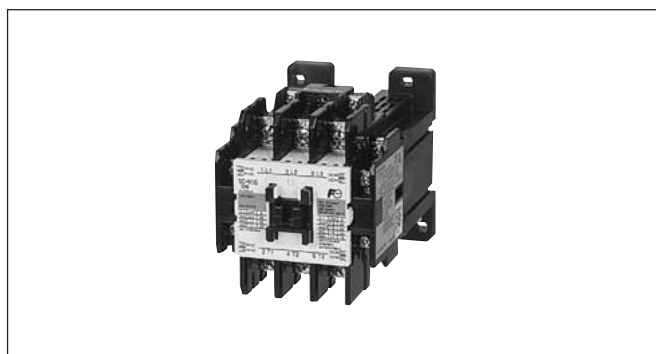

● **Unified mounting hole pitch of contactors and motor starters**

The mounting hole pitches of contactors and motor starters have been standardized. This enables the contactor and the motor starter to be fixed to the same mounting holes. (The holes for SC-N1 to N7 are as same as those for SW-N1/3H to N7/3H respectively.)

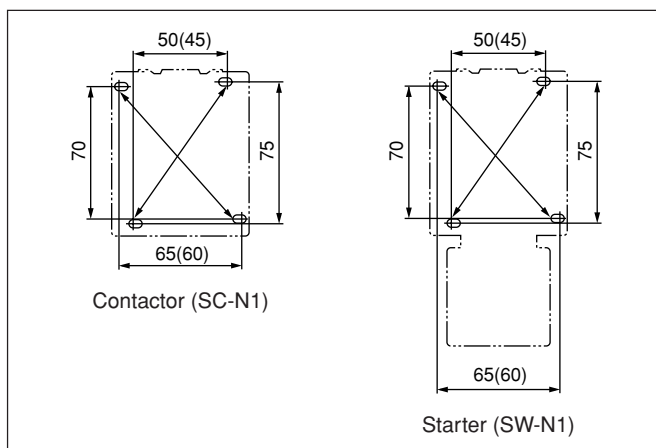

Note: Use the two mounting holes on a diagonal line to mount a contactor.

# Magnetic Contactors and Starters

## SC and SW series

### Design features

#### ● Reduced size and space of contactor

By employing a highly efficient electromagnet (Using 3D magnetic field analysis technology), the depth and mounting space of the contactor has been reduced.

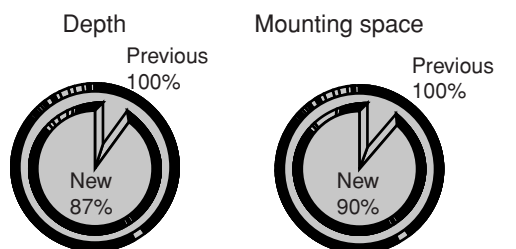

New : Average value for types SC-N4 to N7  
 Previous : Average value for types SC-4N to 7N

#### ● Reduced size and space of motor starter

The depth and mounting spaces of the contactors and thermal overload relays have been reduced by combining them into one unit without a mounting plate.

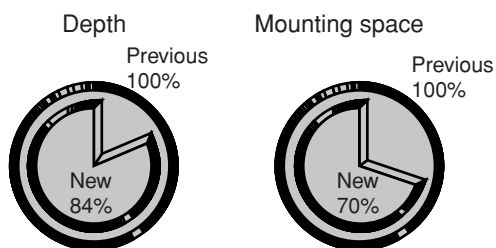

New : Average value for types SW-N4/3H to N7/3H  
 Previous : Average value for types SW-4N/3H to 7N/3H

#### ● Reduced power consumption

By introducing a new type of SUPER MAGNET (Using 3D magnetic field analysis technology), power consumption have been greatly reduced.

##### Power consumption

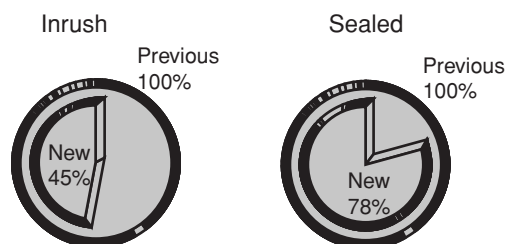

New : Average value for types SC-N5 to N7  
 Previous : Average value for types SC-5N to 7N

#### ● Material designation indication

Recyclable thermoplastic resin is used for plastic parts, and the names of materials are indicated on all major parts to facilitate their recycling.



#### ● Motor starter manufactured at ISO9001 and ISO14001-certified factory

Fuji Electric has been certified for both ISO9000 series and ISO14000 series compliance. Both standards are established by the International Organization for Standardization (ISO). The former is for quality control and quality assurance, while the latter is for environmental management systems. Certified for ISO9001 and ISO14001, our Fukiage Factory, which manufactures motor starters, puts great effort into establishing a highly reliable quality assurance system and a development and production structure which takes environmental protection into account.

**Highly reliable thermal overload relays**

■ **Description**

● FUJI thermal overload relays are designed to provide overload protection to meet the thermal characteristics of low voltage induction motors. Adjustable thermal overload relays give motors positive overcurrent protection. The starter contacts are so arranged that they cannot be held closing under overload conditions. However, once the bimetal element has cooled, the reset button can be depressed and the motor can be restarted in the normal manner. Ordinary this reset is carried out manually but the starter can be changed over to "automatic reset" by means of a screw-driver.

● FUJI relays are extremely accurate. Each thermal overload relay is subjected to stringent testing in the factory to check performance and actual values are calibrated with the marking on the adjustable dial. Consequently, they are extremely accurate and provide a positive protection.

● Relays are also provided with ambient temperature compensators, so that their performance will be maintained in spite of temperature changes. The ambient temperature is regulated for 20°C.

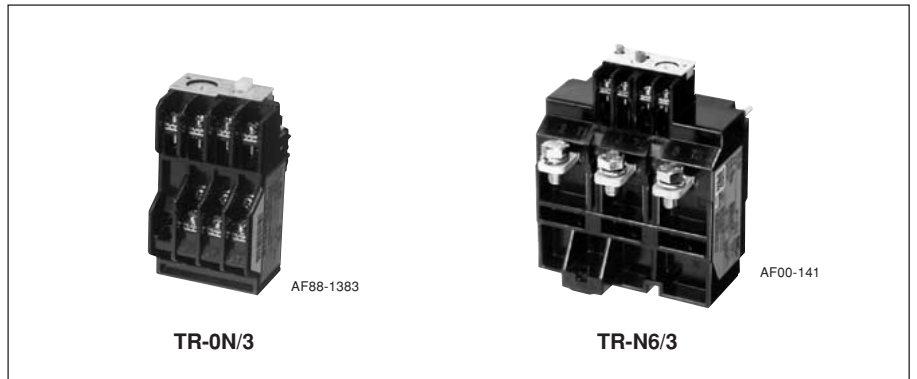

**Auxiliary contact**  
 Isolated NO and NC contacts can be used with different potential.

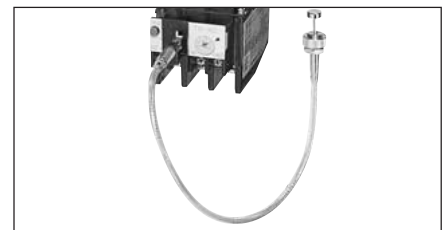

**Reset release button**  
 Reset a thermal overload relay from the rear side of the board or a distant location.

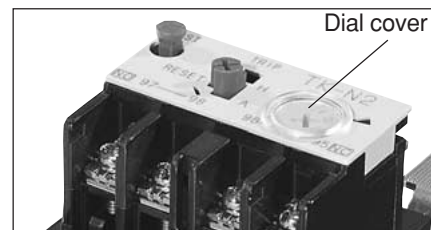

**Dial cover**  
 Protects the setting current value of a thermal overload relay from being changed unintentionally.

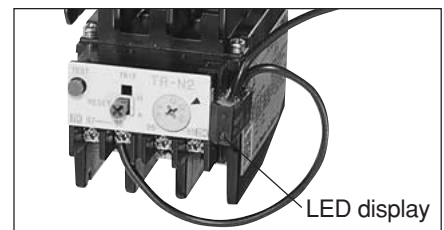

**Trip indicator**  
 Indicates any trip operation through its LED display.



**Type number indication**  
 Type number printed on front side for easy looking.

# Magnetic Contactors and Starters

## SC and SW series

### Versions

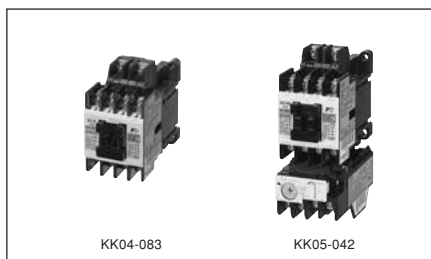

#### Standard type contactors and starters

Standard type is usually used to start and stop motors, and to open and close resistance loads like heaters or electric furnaces.

[See page 01/33.](#)



#### Contactors and starters with SUPER MAGNET

IC operated SUPER MAGNET prevents coil burning and contact welding due to voltage fluctuations

[See page 01/33.](#)



#### Enclosed type starters

Standard type starter are housed in a protective enclosure.

[See page 01/41.](#)



#### Reversing contactors and starters

This type is most suitable for reversing operation of 3-phase motors or plugging or braking.

[See page 01/42.](#)

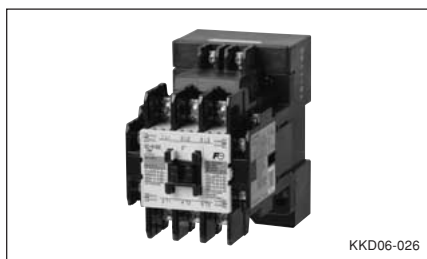

#### DC-operated contactors and starters

Main circuit is AC, and operation is carried out by DC operating coil. This type is useful for applications in which control power source is independent.

[See page 01/49.](#)

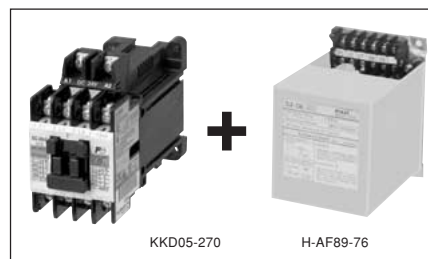

#### OFF-delay release contactors and starters

This is a combination of DC-operated magnetic contactor and off-delay release unit. This prevents circuit opening due to instantaneous voltage drops.

[See page 01/54.](#)



#### With extra pickup operating coil

These contactors are suitable for use in places with poor power supply conditions. These contactors operate normally even if the coil input voltage falls to 75% of the coil rated voltage.

[See page 01/55.](#)

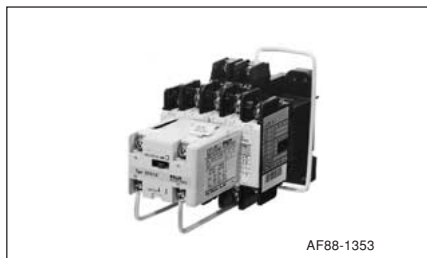

#### Mechanical latch contactors

Latch mechanism prevents the circuit from opening due to power failure, instantaneous power failure, or voltage drop of power source. This is suitable for change-over circuit and stand-by power supply equipment.

[See page 01/56.](#)

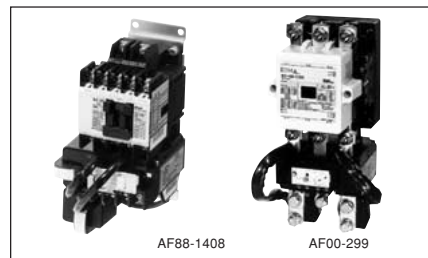

#### Heavy starting duty starters

This is suitable for overload protection or stall prevention of motors with longer starting times such as those for blowers and fans having a large inertia.

[See page 01/61.](#)

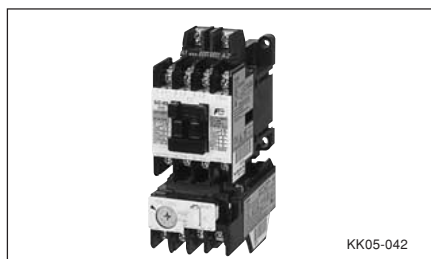

KK05-042

**Starters with quick-operating overload relay**

With the attached quick operating type O/L relay, this is suitable for protecting submersible pumps or compressor motors with a small heat capacity.  
[See page 01/63.](#)

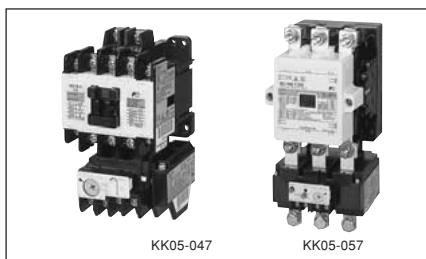

KK05-047

KK05-057

**Starters with phase-loss protective device**

The attached 2E thermal O/L relay protects against motor overload and as well as phase-loss.  
[See page 01/64.](#)

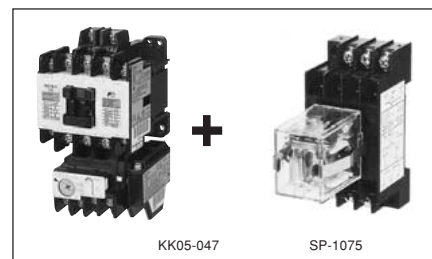

KK05-047

SP-1075

**Starters with phase-loss and phase-sequence protective device**

By combining 2E thermal O/L relay and phase-sequence relay, motor overload, phase-loss and phase-sequence protection is obtained.  
[See page 01/66.](#)

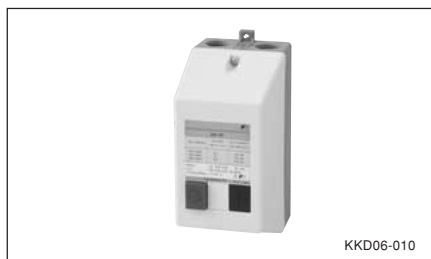

KKD06-010

**Starters with on-off and RESET pushbuttons**

Pushbuttons for close and open are built in the enclosure. Suitable for simple operations.  
[See page 01/68.](#)



SD-704

**Dust-tight/light-corrosion resistant type starters**

The enclosure is dust-tight and corrosion-proof, and so is suitable for locations with dusty or corrosive atmospheres.  
[See page 01/70.](#)

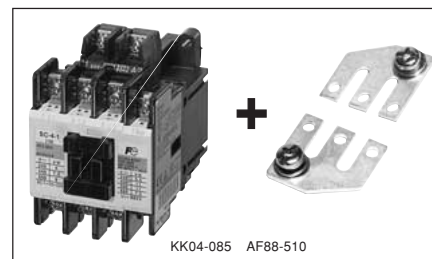

KK04-085

AF88-510

**Contactors for single-phase resistance load**

This is a standard type magnetic contactor with a 3-phase parallel plate terminal. This is most suitable for on-off operation of electric heaters, water heaters and electric lights.  
[See page 01/71.](#)



KKD06-036

**With single-button auxiliary contacts**

An auxiliary contact of a standard contactor is bifurcated. All SC-03H to SC-N12H contactor, however, feature single-button auxiliary contacts with a higher current rating than the contacts used by the standard contactor.  
[See page 01/72.](#)



AF95-240

**With quick connection terminals**

No removing terminal screw is required. When contactor and starters with the quick connection terminals are shipped, these screws are inserted in the terminals section but make no contact. It reduces the number of wiring steps. Terminals with finger protection enable a high level of safety.  
[See page 01/73.](#)

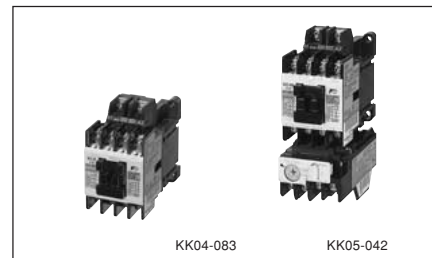

KK04-083

KK05-042

**UL, CSA, TÜV and CCC approved motor starters and contactors**

Many models of SC series conform to UL, CSA, TÜV and CCC requirements.  
[See page 01/129.](#)

# Magnetic Contactors and Starters

## SC and SW series

### Quick selection guide/Open type

#### ■ Types and ratings/Non-reversing, Open

Frame size		03	0	05	4-0	Further information
Max. motor capacity (kW)	200–240V	2.5	3.5	3.5	4.5	
	380–440V	4	5.5	5.5	7.5	
AC-3, IEC 60947-4-1	500–550V	4	5.5	5.5	7.5	
	600–660V	4	5.5	5.5	7.5	
Operational current (A)	200–240V	11	13	13	18	
	380–440V	9	12	12	16	
	500–550V	7	9	9	13	
	600–660V	5	7	7	9	
Operational current (A)	AC-1	20	20	20	25	
Conventional free air thermal current (A)		20	20	20	25	
Auxiliary contact arrangement		1NO 1NC	1NO 1NC	1NO+1NC 2NO, 2NC	1NO 1NC	
Standard	Contact Starter	SC-03 SW-03/3H	SC-0 SW-0/3H	SC-05 SW-05/3H	SC-4-0 SW-4-0/3H	<a href="#">Page 01/33</a>
DC operated	Contact Starter	SC-03/G SW-03/G3H	SC-0/G SW-0/G3H	SC-05/G SW-05/G3H	SC-4-0/G SW-4-0/G3H	<a href="#">Page 01/49</a>
OFF-delay release *1	Contact Starter	SC-03/G+SZ-DE□ SW-03/G3H+ SZ-DE□	SC-0/G+SZ-DE□ SW-0/G3H+ SZ-DE□	SC-05/G+SZ-DE□ SW-05/G3H+ SZ-DE□	SC-4-0/G+SZ-DE□ SW-4-0/G3H+ SZ-DE□	<a href="#">Page 01/54</a>
With extra pick-up operating coil	Contact Starter	SC-03/U SW-03/U3H	SC-0/U SW-0/U3H	SC-05/U SW-05/U3H	SC-4-0/U SW-4-0/U3H	<a href="#">Page 01/55</a>
Mechanical latch AC operated	Contact Starter	SC-03/V –	SC-0/V –	SC-05/V –	SC-4-0/V –	<a href="#">Page 01/56</a>
Mechanical latch DC operated	Contact Starter	SC-03/VG –	SC-0/VG –	SC-05/VG –	SC-4-0/VG –	<a href="#">Page 01/56</a>
Heavy starting duty	Contact Starter	– SW-03/3L	– SW-0/3L	– SW-05/3L	– SW-4-0/3L	<a href="#">Page 01/61</a>
With quick operating overload relay	Contact Starter	– SW-03/3Q	– SW-0/3Q	– SW-05/3Q	– SW-4-0/3Q	<a href="#">Page 01/63</a>
With phase-loss protective device	Contact Starter	– SW-03/2E	– SW-0/2E	– SW-05/2E	– SW-4-0/2E	<a href="#">Page 01/64</a>
With phase-loss and phase sequence protective device *2	Contact Starter	– SW-03/2E+QE-□0N	– SW-0/2E+QE-□0N	– SW-05/2E+QE-□0N	– SW-4-0/2E+QE-□0N	<a href="#">Page 01/66</a>
For single-phase resistance load	Contact Starter	SC-03+SZ-SP1 –	SC-0+SZ-SP1 –	SC-05+SZ-SP1 –	SC-4-0+SZ-SP2 –	<a href="#">Page 01/71</a>
With quick connection terminals	Contact starter	SC-03Y SW-03Y	SC-0Y SW-0Y	SC-05Y SW-05Y	– –	<a href="#">Page 01/73</a>
Thermal overload relay On-contactor mounting						<a href="#">Page 01/97</a>
Standard		TR-0N/3	TR-0N/3	TR-0N/3	TR-5-1N/3	
Long time operation		TR-0NL/3	TR-0NL/3	TR-0NL/3	TR-5-1NL/3	
Quick operation		TR-0NQ	TR-0NQ	TR-0NQ	TR-5-1NQ	
Phase-loss protection		TK-0N	TK-0N	TK-0N	TK-5-1N	

Note: \*1 Replace the □ mark in the type number by the operating voltage code.  
100V AC: 100, 110V AC: 110, 200V AC: 200, 220V AC: 220

\*2 Replace the □ mark in the type number by the operating voltage code.  
200-220V AC: 2, 380-415V AC: 4



■ **Types and ratings/Non-reversing, Open**

Frame size		<b>4-1</b>	<b>5-1</b>	<b>N1</b>	<b>N2</b>	Further information
Max. motor capacity (kW)	200–240V	5.5	5.5	7.5	11	
	380–440V	11	11	15	18.5	
AC-3, IEC 60947-4-1	500–550V	11	11	15	18.5	
	600–660V	7.5	7.5	11	15	
Operational current (A)	200–240V	22	22	32	40	
	380–440V	22	22	32	40	
	500–550V	17	17	24	29	
	600–660V	9	9	15	19	
Operational current (A)	AC-1	32	32	50	60	
Conventional free air thermal current (A)		32	32	50	60	
Auxiliary contact arrangement		1NO 1NC	1NO+1NC, 2NO 2NO+2NC, 2NC	2NO+2NC 4NO+4NC	2NO+2NC 4NO+4NC	
Standard	Contactors Starter	SC-4-1 SW-4-1/3H	SC-5-1 SW-5-1/3H	SC-N1 SW-N1/3H	SC-N2 SW-N2/3H	<a href="#">Page 01/33</a>
DC operated	Contactors Starter	SC-4-1/G SW-4-1/G3H	SC-5-1/G SW-5-1/G3H	SC-N1/G SW-N1/G3H	SC-N2/G SW-N2/G3H	<a href="#">Page 01/49</a>
OFF-delay release *1	Contactors Starter	SC-4-1/G+SZ-DE□ SW-4-1/G3H+ SZ-DE□	SC-5-1/G+SZ-DE□ SW-5-1/G3H+ SZ-DE□	SC-N1/G+ SZ-N1/GDE SW-N1/G3H+ SZ-N1/GDE	SC-N2/G+ SZ-N1/GDE SW-N2/G3H+ SZ-N1/GDE	<a href="#">Page 01/54</a>
With extra pick-up operating coil	Contactors Starter	SC-4-1/U SW-4-1/U3H	SC-5-1/U SW-5-1/U3H	SC-N1/U SW-N1/U3H	SC-N2/U SW-N2/U3H	<a href="#">Page 01/55</a>
Mechanical latch AC operated	Contactors Starter	SC-4-1/V –	SC-5-1/V –	SC-N1/VS –	SC-N2/VS –	<a href="#">Page 01/56</a>
Mechanical latch DC operated	Contactors Starter	SC-4-1/VG –	SC-5-1/VG –	SC-N1/VS –	SC-N2/VS –	<a href="#">Page 01/56</a>
Heavy starting duty	Contactors Starter	– SW-4-1/3L	– SW-5-1/3L	– SW-N1/3L	– SW-N2/3L	<a href="#">Page 01/61</a>
With quick operating overload relay	Contactors Starter	– SW-4-1/3Q	– SW-5-1/3Q	– SW-N1/3Q	– SW-N2/3Q	<a href="#">Page 01/63</a>
With phase-loss protective device	Contactors Starter	– SW-4-1/2E	– SW-5-1/2E	– SW-N1/2E	– SW-N2/2E	<a href="#">Page 01/64</a>
With phase-loss and phase sequence protective device *2	Contactors Starter	– SW-4-1/2E+QE-□0N	– SW-5-1/2E+QE-□0N	– SW-N1/2E+QE-□0N	– SW-N2/2E+QE-□0N	<a href="#">Page 01/66</a>
For single-phase resistance load	Contactors Starter	SC-4-1+SZ-SP2 –	SC-5-1+SZ-SP2 –	SC-N1+SZ-SP3 –	SC-N2+SZ-SP3 –	<a href="#">Page 01/71</a>
With quick connection terminals	Contactors starter	– –	SC-5-1Y SW-5-1Y	– –	– –	<a href="#">Page 01/73</a>
Thermal overload relay On-contactor mounting						<a href="#">Page 01/97</a>
Standard		TR-5-1N/3	TR-5-1N/3	TR-N2/3	TR-N2/3	
Long time operation		TR-5-1NL/3	TR-5-1NL/3	TR-N2L/3	TR-N2L/3	
Quick operation		TR-5-1NQ	TR-5-1NQ	TR-N2Q	TR-N2Q	
Phase-loss protection		TK-5-1N	TK-5-1N	TK-N2	TK-N2	

Note: \*1 Replace the □ mark in the type number by the operating voltage code.  
100V AC: 100, 110V AC: 110, 200V AC: 200, 220V AC: 220

\*2 Replace the □ mark in the type number by the operating voltage code.  
200-220V AC: 2, 380-415V AC: 4

# Magnetic Contactors and Starters

## SC and SW series

### Quick selection guide/Open type

#### ■ Types and ratings/Non-reversing, Open

Frame size		N2S	N3	N4	N5	Further information	
Max. motor capacity (kW)	200–240V	15	18.5	22	30		
	380–440V	22	30	40	55		
	AC-3, IEC 60947-4-1	500–550V	25	37	37		55
		600–660V	22	30	37		55
Operational current (A)	200–240V	50	65	80	105		
	380–440V	50	65	80	105		
	500–550V	38	60	60	85		
	600–660V	26	38	44	64		
Operational current (A)	AC-1	80	100	135	150		
Conventional free air thermal current (A)		80	100	135	150		
Auxiliary contact arrangement		2NO+2NC 4NO+4NC	2NO+2NC 4NO+4NC	2NO+2NC 4NO+4NC	2NO+2NC 4NO+4NC		
Standard	Contactors Starter	SC-N2S SW-N2S/3H	SC-N3 SW-N3/3H	SC-N4 SW-N4/3H	SC-N5 SW-N5/3H	<a href="#">Page 01/33</a>	
DC operated	Contactors Starter	SC-N2S/G SW-N2S/G3H	SC-N3/G SW-N3/G3H	SC-N4/SE SW-N4/SE3H	SC-N5 SW-N5/3H	<a href="#">Page 01/49</a>	
OFF-delay release	Contactors Starter	SC-N2S/G+ SZ-N2S/GDE SW-N2S/G3H+ SZ-N2S/GDE	SC-N3/G+ SZ-N2S/GDE SW-N3/G3H+ SZ-N2S/GDE	SC-N4/SE+ SZ-N5/DE SW-N4/SE3H+ SZ-N5/SEDE	SC-N5+ SZ-5N/DE SW-N5/3H+ SZ-N5/DE	<a href="#">Page 01/54</a>	
With extra pick-up operating coil <sup>*1</sup>	Contactors Starter	SC-N2S/U SW-N2S/U3H	SC-N3/U SW-N3/U3H	SC-N4/U SW-N4/U3H	– –	<a href="#">Page 01/55</a>	
Mechanical latch AC operated	Contactors Starter	SC-N2S/VS –	SC-N3/VS –	SC-N4/VS –	SC-N5/VS –	<a href="#">Page 01/56</a>	
Mechanical latch DC operated	Contactors Starter	SC-N2S/VS –	SC-N3/VS –	SC-N4/VS –	SC-N5/VS –	<a href="#">Page 01/56</a>	
Heavy starting duty	Contactors Starter	– SW-N2S/3L	– SW-N3/3L	– SW-N4/3L	– SW-N5/3L	<a href="#">Page 01/61</a>	
With quick operating overload relay	Contactors Starter	– SW-N2S/3Q	– SW-N3/3Q	– SW-N4/3Q	– SW-N5/3Q	<a href="#">Page 01/63</a>	
With phase-loss protective device	Contactors Starter	– SW-N2S/2E	– SW-N3/2E	– SW-N4/2E	– SW-N5/2E	<a href="#">Page 01/64</a>	
With phase-loss and phase sequence protective device <sup>*2</sup>	Contactors Starter	– SW-N2S/2E+QE-□0N	– SW-N3/2E+QE-□0N	– SW-N4/2E+QE-□0N	– SW-N5/2E+QE-□0N	<a href="#">Page 01/66</a>	
For single-phase resistance load	Contactors Starter	SC-N2S+SZ-SP4 –	SC-N3+SZ-SP4 –	SC-N4+SZ-SP5 –	SC-N5+SZ-SP5 –	<a href="#">Page 01/71</a>	
Thermal overload relay On-contactor mounting						<a href="#">Page 01/97</a>	
Standard		TR-N3/3	TR-N3/3	TR-N5/3	TR-N5/3		
Long time operation		TR-N3L/3	TR-N3L/3	TR-N5L/3	TR-N5L/3		
Quick operation		TR-N3Q	TR-N3Q	TR-N5Q	TR-N5Q		
Phase-loss protection		TK-N3	TK-N3	TK-N5	TK-N5		

Note: <sup>\*1</sup> The standard types for frame sizes N5 and above (with SUPER MAGNET) hold without chattering even if the line voltage drops to 65% of its rated value.

<sup>\*2</sup> Replace the □ mark in the type number by the operating voltage code.

200-220V AC: 2, 380-415V AC: 4

■ **Types and ratings/Non-reversing, Open**

Frame size		<b>N6</b>	<b>N7</b>	<b>N8</b>	<b>N10</b>	Further information
Max. motor capacity (kW)	200–240V	37	45	55	65	
	380–440V	60	75	90	110	
AC-3, CEC 60947-4-1	500–550V	60	75	130	132	
	600–660V	60	90	132	132	
Operational current (A)	200–240V	125	150	180	220	
	380–440V	125	150	180	220	
	500–550V	90	120	180	200	
	600–660V	72	103	150	150	
Operational current (A)	AC-1	150	200	260	260	
Conventional free air thermal current (A)		150	200	260	260	
Auxiliary contact arrangement		2NO+2NC 4NO+4NC	2NO+2NC 4NO+4NC	2NO+2NC 4NO+4NC	2NO+2NC 4NO+4NC	
Standard	Contact Starter	SC-N6 SW-N6/3H	SC-N7 SW-N7/3H	SC-N8 SW-N8/3H	SC-N10 SW-N10/3H	<a href="#">Page 01/33</a>
DC operated	Contact Starter	SC-N6 SW-N6/3H	SC-N7 SW-N7/3H	SC-N8 SW-N8/3H	SC-N10 SW-N10/3H	<a href="#">Page 01/49</a>
OFF-delay release	Contact Starter	SC-N6+SZ-N6/DE SW-N6/3H+ SZ-N6/DE	SC-N7+SZ-N6/DE SW-N7/3H+ SZ-N6/DE	SC-N8+SZ-N8/DE SW-N8/3H+ SZ-N8/DE	SC-N10+SZ-N8/DE SW-N10/3H+ SZ-N8/DE	<a href="#">Page 01/54</a>
With extra pick-up operating coil *1	Contact Starter	– –	– –	– –	– –	– –
Mechanical latch/ AC operated	Contact Starter	SC-N6/VS –	SC-N7/VS –	SC-N8/VS –	SC-N10/VS –	<a href="#">Page 01/56</a>
Mechanical latch/ DC operated	Contact Starter	SC-N6/VS –	SC-N7/VS –	SC-N8/VS –	SC-N10/VS –	<a href="#">Page 01/56</a>
Heavy starting duty	Contact Starter	– SW-N6/3L	– SW-N7/3L	– SW-N8/3L	– SW-N10/3L	<a href="#">Page 01/61</a>
With quick operating overload relay	Contact Starter	– –	– –	– –	– –	<a href="#">Page 01/63</a>
With phase-loss protective device	Contact Starter	– SW-N6/2E	– SW-N7/2E	– SW-N8/2E	– SW-N10/2E	<a href="#">Page 01/64</a>
With phase-loss and phase sequence protective device *2	Contact Starter	– SW-N6/2E+QE-□0N	– SW-N7/2E+QE-□0N	– SW-N8/2E+QE-□0N	– SW-N10/2E+QE-□0N	<a href="#">Page 01/66</a>
For single-phase resistance load	Contact Starter	SC-N6+SZ-SP7 –	SC-N7+SZ-SP7 –	SC-N8+SZ-SP8 –	SC-N10+SZ-SP8 –	<a href="#">Page 01/71</a>
Thermal overload relay On-contactor mounting						<a href="#">Page 01/97</a>
Standard		TR-N6/3	TR-N7/3	TR-N8/3	TR-N10/3	
Long time operation		TR-N6L/3	TR-N7L/3	TR-N10L/3	TR-N10L/3	
Quick operation		–	–	–	–	
Phase-loss protection		TK-N6	TK-N7	TK-N8	TK-N10	

Note: \*1 The standard types for frame sizes N5 and above (with SUPER MAGNET) hold without chattering even if the line voltage drops to 65% of its rated value.

\*2 Replace the □ mark in the type number by the operating voltage code.

200-220V AC: 2, 380-415V AC: 4

# Magnetic Contactors and Starters

## SC and SW series

### Quick selection guide/Open type

#### ■ Types and ratings/Non-reversing, Open

Frame size		N11	N12	N14	N16	Further information
Max. motor capacity (kW)	200–240V	90	120	180	220	
	380–440V	160	220	315	440	
AC-3, IEC 60947-4-1	500–550V	160	250	400	500	
	600–660V	200	300	480	500	
Operational current (A)	200–240V	300	400	600	800	
	380–440V	300	400	600	800	
	500–550V	230	360	600	720	
	600–660V	230	360	600	630	
Operational current (A)	AC-1	350	450	660	800	
Conventional free air thermal current (A)		350	450	660	800	
Auxiliary contact arrangement		2NO+2NC 4NO+4NC	2NO+2NC 4NO+4NC	2NO+2NC 4NO+4NC	2NO+2NC 4NO+4NC	
Standard	Contactors Starter	SC-N11 SW-N11/3H	SC-N12 SW-N12/3H	SC-N14 SW-N14/3H	SC-N16 –	<a href="#">Page 01/33</a>
DC operated	Contactors Starter	SC-N11 SW-N11/3H	SC-N12 SW-N12/3H	SC-N14 SW-N14/3H	SC-N16 –	<a href="#">Page 01/49</a>
OFF-delay release	Contactors Starter	SC-N11+SZ-N11/DE SW-N11/3H+ SZ-N11/DE	SC-N12+SZ-N11/DE SW-N12/3H+ SZ-N11/DE	SC-N14+SZ-N14/DE SW-N14/3H+ SZ-N14/DE	– – –	<a href="#">Page 01/54</a>
With extra pick-up operating coil <sup>*1</sup>	Contactors Starter	– –	– –	– –	– –	– –
Mechanical latch AC operated	Contactors Starter	SC-N11/VS –	SC-N12/VS –	SC-N14/VS –	– –	<a href="#">Page 01/56</a>
Mechanical latch DC operated	Contactors Starter	SC-N11/VS –	SC-N12/VS –	SC-N14/VS –	– –	<a href="#">Page 01/56</a>
Heavy starting duty	Contactors Starter	– SW-N11/3L	– SW-N12/3L	– SW-N14/3L	– –	<a href="#">Page 01/61</a>
With quick operating overload relay	Contactors Starter	– –	– –	– –	– –	– –
With phase-loss protective device	Contactors Starter	– SW-N11/2E	– SW-N12/2E	– SW-N14/2E	– –	<a href="#">Page 01/64</a>
With phase-loss and phase sequence protective device <sup>*2</sup>	Contactors Starter	– SW-N11/2E+QE-□0N	– SW-N12/2E+QE-□0N	– SW-N14/2E+QE-□0N	– –	<a href="#">Page 01/66</a>
For single-phase resistance load	Contactors Starter	SC-N11+SZ-SP9 –	SC-N12+SZ-SP9 –	SC-N14+SZ-SP10 –	SC-N16+SZ-SP10 –	<a href="#">Page 01/71</a>
Thermal overload relay On-contactor mounting						<a href="#">Page 01/97</a>
Standard		TR-N12/3	TR-N12/3	TR-N14/3	–	
Long time operation		TR-N12L/3	TR-N12L/3	TR-N14L/3	–	
Quick operation		–	–	–	–	
Phase-loss protection		TK-N12	TK-N12	TK-N14	–	

Note: <sup>\*1</sup> The standard types for frame sizes N5 and above (with SUPER MAGNET) hold without chattering even if the line voltage drops to 65% of its rated value.

<sup>\*2</sup> Replace the □ mark in the type number by the operating voltage code.

200-220V AC: 2, 380-415V AC: 4

■ **Types and ratings/Non-reversing, Enclosed**

Frame size		<b>03</b>	<b>0</b>	<b>05</b>	<b>4-0</b>	Further information	
Max. motor capacity (kW)	200–240V	2.5	3.5	3.5	4.5		
	380–440V	4	5.5	5.5	7.5		
AC-3, IEC 60947-4-1	500–550V	4	5.5	5.5	7.5		
	600–660V	4	5.5	5.5	7.5		
Operational current (A)	200–240V	11	13	13	18		
	380–440V	9	12	12	16		
	500–550V	7	9	9	13		
	600–660V	5	7	7	9		
Operational current (A)	AC-1	20	20	20	25		
Conventional free air thermal current (A)		20	20	20	25		
Auxiliary contact arrangement		1NO 1NC	1NO 1NC	1NO+1NC 2NO, 2NC	1NO 1NC		
Standard	Contact Starter	SC-03C SW-03C/3H	SC-0C SW-0C/3H	SC-05C SW-05C/3H	SC-4-0C SW-4-0C/3H	<a href="#">Page 01/33</a>	
With extra pick-up operating coil	Contact Starter	– SW-03C/U3H	– SW-0C/U3H	– SW-05C/U3H	– SW-4-0C/U3H	<a href="#">Page 01/55</a>	
With phase-loss protective device	Contact Starter	– SW-03C/2E	– SW-0C/2E	– SW-05C/2E	– SW-4-0C/2E	<a href="#">Page 01/64</a>	
With ON-OFF/reset pushbuttons	Contact Starter	– SW-03P/3H	– SW-0P/3H	– SW-05P/3H	– SW-4-0P/3H	<a href="#">Page 01/68</a>	
Dust tight/light corrosion resistant	Contact Starter	– SW-03LG/3H	– SW-0LG/3H	– SW-05LG/3H	– SW-4-0LG/3H	<a href="#">Page 01/70</a>	
Thermal overload relay		<a href="#">See page 01/12.</a> Same as the open types				<a href="#">Page 01/97</a>	

Frame size		<b>4-1</b>	<b>5-1</b>	<b>N1</b>	<b>N2</b>	Further information	
Max. motor capacity (kW)	200–240V	5.5	5.5	7.5	11		
	380–440V	11	11	15	18.5		
AC-3, IEC 60947-4-1	500–550V	11	11	15	18.5		
	600–660V	7.5	7.5	11	15		
Operational current (A)	200–240V	22	22	32	40		
	380–440V	22	22	32	40		
	500–550V	17	17	24	29		
	600–660V	9	9	15	19		
Operational current (A)	AC-1	32	32	50	60		
Conventional free air thermal current (A)		32	32	50	60		
Auxiliary contact arrangement		1NO 1NC	1NO+1NC 2NO, 2NC	2NO+2NC 4NO+4NC	2NO+2NC 4NO+4NC		
Standard	Contact Starter	SC-4-1C SW-4-1C/3H	SC-5-1C SW-5-1C/3H	SC-N1C SW-N1C/3H	SC-N2C SW-N2C/3H	<a href="#">Page 01/33</a>	
With extra pick-up operating coil	Contact Starter	– SW-4-1C/U3H	– SW-5-1C/U3H	– SW-N1C/U3H	– SW-N2C/U3H	<a href="#">Page 01/55</a>	
With phase-loss protective device	Contact Starter	– SW-4-1C/2E	– SW-5-1C/2E	– SW-N1C/2E	– SW-N2C/2E	<a href="#">Page 01/64</a>	
With ON-OFF pushbuttons	Contact Starter	– –	– –	– SW-N1P/3H	– SW-N2P/3H	<a href="#">Page 01/68</a>	
With ON-OFF/reset pushbuttons	Contact Starter	– SW-4-1P/3H	– SW-5-1P/3H	– SW-N1PB/3H	– SW-N2PB/3H	<a href="#">Page 01/68</a>	
Dust tight/light corrosion resistant	Contact Starter	– SW-4-1LG/3H	– SW-5-1LG/3H	– SW-N1LG/3H	– SW-N2LG/3H	<a href="#">Page 01/70</a>	
Thermal overload relay		<a href="#">See page 01/13.</a> Same as the open types				<a href="#">Page 01/97</a>	

# Magnetic Contactors and Starters

## SC and SW series

### Quick selection guide/Enclosed type

#### ■ Types and ratings/Non-reversing, Enclosed

Frame size		N2S	N3	N4	N5	Further information	
Max. motor capacity (kW)	200–240V	15	18.5	22	30		
	380–440V	22	30	40	55		
AC-3, IEC 60947-4-1	500–550V	25	37	37	55		
	600–660V	22	30	37	55		
Operational current (A)	200–240V	50	65	80	105		
	380–440V	50	65	80	105		
	500–550V	38	60	60	85		
	600–660V	26	38	44	64		
Operational current (A)	AC-1	80	100	135	150		
Conventional free air thermal current (A)		80	100	135	150		
Auxiliary contact arrangement		2NO+2NC 4NO+4NC	2NO+2NC 4NO+4NC	2NO+2NC 4NO+4NC	2NO+2NC 4NO+4NC		
Standard	Contactors Starter	SC-N2SC SW-N2SC/3H	SC-N3C SW-N3C/3H	SC-N4C SW-N4C/3H	SC-N5C SW-N5C/3H	Page 01/33	
With extra pick-up operating coil *	Contactors Starter	– SW-N2SC/U3H	– SW-N3C/U3H	– SW-N4C/SE3H	– –	Page 01/55	
With phase-loss protective device	Contactors Starter	– SW-N2SC/2E	– SW-N3C/2E	– SW-N4C/2E	– SW-N5C/2E	Page 01/64	
With ON-OFF pushbuttons	Contactors Starter	– SW-N2SP/3H	– SW-N3P/3H	– –	– –	Page 01/68	
With ON-OFF and reset pushbuttons	Contactors Starter	– SW-N2SPB/3H	– SW-N3PB/3H	– SW-N4PB/3H	– SW-N5PB/3H	Page 01/68	
Dust tight/light corrosion resistant	Contactors Starter	– SW-N2SLG/3H	– SW-N3LG/3H	– SW-N4LG/3H	– SW-N5LG/3H	Page 01/70	
Thermal overload relay		<a href="#">See page 01/14.</a> Same as the open types				Page 01/97	

Frame size		N6	N7	N8	N10	Further information	
Max. motor capacity (kW)	200–240V	37	45	55	65		
	380–440V	60	75	90	110		
AC-3, IEC 60947-4-1	500–550V	60	75	130	132		
	600–660V	60	90	132	132		
Operational current (A)	200–240V	125	150	180	220		
	380–440V	125	150	180	220		
	500–550V	90	120	180	200		
	600–660V	72	103	150	150		
Operational current (A)	AC-1	150	200	260	260		
Conventional free air thermal current (A)		150	200	260	260		
Auxiliary contact arrangement		2NO+2NC 4NO+4NC	2NO+2NC 4NO+4NC	2NO+2NC 4NO+4NC	2NO+2NC 4NO+4NC		
Standard	Contactors Starter	SC-N6C SW-N6C/3H	SC-N7C SW-N7C/3H	SC-N8C SW-N8C/3H	SC-N10C SW-N10C/3H	Page 01/33	
With extra pick-up operating coil *	Contactors Starter	– –	– –	– –	– –	– –	
With phase-loss protective device	Contactors Starter	– SW-N6C/2E	– SW-N7C/2E	– SW-N8C/2E	– SW-N10C/2E	Page 01/64	
With ON-OFF pushbuttons	Contactors Starter	– –	– –	– –	– –	– –	
With ON-OFF and reset pushbuttons	Contactors Starter	– SW-N6PB/3H	– –	– SW-N8PB/3H	– SW-N10PB/3H	Page 01/68	
Dust tight/light corrosion resistant	Contactors Starter	– SW-N6LG/3H	– SW-N7LG/3H	– SW-N8LG/3H	– SW-N10LG/3H	Page 01/70	
Thermal overload relay		<a href="#">See page 01/15.</a> Same as the open types				Page 01/97	

Note: \* The standard types for frame sizes N5 and above (with SUPER MAGNET) hold without chattering even if the line voltage drops to 65% of its rated value.

■ **Types and ratings/Non-reversing, Enclosed**

Frame size		N11	N12	N14	N16	Further information
Max. motor capacity (kW)	200–240V	90	120	180	–	
	380–440V	160	220	315	–	
AC-3, IEC 60947-4-1	500–550V	160	250	400	–	
	600–660V	200	300	480	–	
Operational current (A)	200–240V	300	400	600	–	
	380–440V	300	400	600	–	
	500–550V	230	360	600	–	
	600–660V	230	360	600	–	
Operational current (A)	AC-1	350	450	660	–	
Conventional free air thermal current (A)		350	450	660	–	
Auxiliary contact arrangement		2NO+2NC 4NO+4NC	2NO+2NC 4NO+4NC	2NO+2NC 4NO+4NC	– –	
Standard	Contactors	SC-N11C	SC-N12C	SC-N14C	–	<i>Page 01/33</i>
	Starters	SW-N11C/3H	SW-N12C/3H	SW-N14C/3H	–	
With extra pick-up operating coil *	Contactors	–	–	–	–	–
	Starters	–	–	–	–	–
With phase-loss protective device	Contactors	–	–	–	–	<i>Page 01/64</i>
	Starters	SW-N11C/2E	SW-N12C/2E	SW-N14C/2E	–	
With ON-OFF pushbuttons	Contactors	–	–	–	–	–
	Starters	–	–	–	–	–
With ON-OFF and reset pushbuttons	Contactors	–	–	–	–	–
	Starters	–	–	–	–	–
Dust tight/light corrosion resistant	Contactors	–	–	–	–	–
	Starters	–	–	–	–	–
Thermal overload relay		<i>See page 01/16.</i> Same as the open types				<i>Page 01/97</i>

Note: \* The standard types for frame sizes N5 and above (with SUPER MAGNET) hold without chattering even if the line voltage drops to 65% of its rated value.

# Magnetic Contactors and Starters

## SC and SW series

### Quick selection guide/Reversing, Open type

#### ■ Types and ratings/Reversing, Open

Frame size		03	0	05	4-0	Further information
Max. motor capacity (kW)	200–240V	2.5	3.5	3.5	4.5	
	380–440V	4	5.5	5.5	7.5	
AC-3, IEC 60947-4-1	500–550V	4	5.5	5.5	7.5	
	600–660V	4	5.5	5.5	7.5	
Operational current (A)	200–240V	11	13	13	18	
	380–440V	9	12	12	16	
	500–550V	7	9	9	13	
	600–660V	5	7	7	9	
Conventional free air thermal current (A)		20	20	20	25	
Auxiliary contact arrangement		1NC×2 1NO×2	1NC×2 1NO×2	(1NO+1NC)×2 2NC×2	1NC×2 1NO×2	
Standard	Contactor Starter	SC-03RM SW-03RM/3H	SC-0RM SW-0RM/3H	SC-05RM SW-05RM/3H	SC-4-0RM SW-4-0RM/3H	<a href="#">Page 01/42</a>
DC operated	Contactor Starter	SC-03RM/G SW-03RM/G3H	SC-0RM/G SW-0RM/G3H	SC-05RM/G SW-05RM/G3H	SC-4-0RM/G SW-4-0RM/G3H	<a href="#">Contact FUJI</a>
Mechanical latch AC operated	Contactor Starter	SC-03RM/V –	SC-0RM/V –	SC-05RM/V –	SC-4-0RM/V –	<a href="#">Page 01/56</a>
Mechanical latch DC operated	Contactor Starter	SC-03RM/VG –	SC-0RM/VG –	SC-05RM/VG –	SC-4-0RM/VG –	<a href="#">Page 01/56</a>
With phase-loss protective device	Contactor Starter	– SW-03RM/2E	– SW-0RM/2E	– SW-05RM/2E	– SW-4-0RM/2E	<a href="#">Page 01/64</a>
Thermal overload relay On-contactor mounting						<a href="#">Page 01/97</a>
Standard Phase-loss protection		TR-0N/3 TK-0N	TR-0N/3 TK-0N	TR-0N/3 TK-0N	TR-5-1N/3 TK-5-1N	

Frame size		4-1	5-1	N1	N2	Further information
Max. motor capacity (kW)	200–240V	5.5	5.5	7.5	11	
	380–440V	11	11	15	18.5	
AC-3, IEC 60947-4-1	500–550V	11	11	15	18.5	
	600–660V	7.5	7.5	11	15	
Operational current (A)	200–240V	22	22	32	40	
	380–440V	22	22	32	40	
	500–550V	17	17	24	29	
	600–660V	9	9	15	19	
Conventional free air thermal current (A)		32	32	50	60	
Auxiliary contact arrangement		1NC×2 1NO×2	(1NO+1NC)×2,2NC×2 (2NO+2NC)×2	(2NO+2NC)×2 (3NO+3NC)×2	(2NO+2NC)×2 (3NO+3NC)×2	
Standard	Contactor Starter	SC-4-1RM SW-4-1RM/3H	SC-5-1RM SW-5-1RM/3H	SC-N1RM SW-N1RM/3H	SC-N2RM SW-N2RM/3H	<a href="#">Page 01/42</a>
DC operated	Contactor Starter	SC-4-1RM/G SW-4-1RM/G3H	SC-5-1RM/G SW-5-1RM/G3H	SC-N1RM/G SW-N1RM/G3H	SC-N2RM/G SW-N2RM/G3H	<a href="#">Contact FUJI</a>
Mechanical latch AC operated	Contactor Starter	SC-4-1RM/V –	SC-5-1RM/V –	SC-N1RM/VS –	SC-N2RM/VS –	<a href="#">Page 01/56</a>
Mechanical latch DC operated	Contactor Starter	SC-4-1RM/VG –	SC-5-1RM/VG –	SC-N1RM/VS –	SC-N2RM/VS –	<a href="#">Page 01/56</a>
With phase-loss protective device	Contactor Starter	– SW-4-1RM/2E	– SW-5-1RM/2E	– SW-N1RM/2E	– SW-N2RM/2E	<a href="#">Page 01/64</a>
Thermal overload relay On-contactor mounting						<a href="#">Page 01/97</a>
Standard Phase-loss protection		TR-5-1N/3 TK-5-1N	TR-5-1N/3 TK-5-1N	TR-N2/3 TK-N2	TR-N2/3 TK-N2	

Note: Auxiliary contact arrangements indicate the ones for types except mechanical latch types.



■ **Types and ratings/Reversing, Open**

Frame size		N2S	N3	N4	N5	Further information
Max. motor capacity (kW)	200–240V	15	18.5	22	30	
	380–440V	22	30	40	55	
AC-3, IEC 60947-4-1	500–550V	25	37	37	55	
	600–660V	22	30	37	55	
Operational current (A)	200–240V	50	65	80	105	
	380–440V	50	65	80	105	
	500–550V	38	60	60	85	
	600–660V	26	38	44	64	
Conventional free air thermal current (A)		80	100	135	150	
Auxiliary contact arrangement		(2NO+2NC)×2 (3NO+3NC)×2	(2NO+2NC)×2 (3NO+3NC)×2	(2NO+2NC)×2 (3NO+3NC)×2	(2NO+2NC)×2 (3NO+3NC)×2	
Standard	Contactor Starter	SC-N2SRM SW-N2SRM/3H	SC-N3RM SW-N3RM/3H	SC-N4RM SW-N4RM/3H	SC-N5RM SW-N5RM/3H	<a href="#">Page 01/42</a>
DC operated	Contactor Starter	SC-N2SRM/G SW-N2SRM/G3H	SC-N3RM/G SW-N3RM/G3H	SC-N4RMSE SW-N4RM/SE3H	SC-N5RM SW-N5RM/3H	<a href="#">Contact FUJI</a>
Mechanical latch AC operated	Contactor Starter	SC-N2SRM/VS –	SC-N3RM/VS –	SC-N4RM/VS –	SC-N5RM/VS –	<a href="#">Page 01/56</a>
Mechanical latch DC operated	Contactor Starter	SC-N2SRM/VS –	SC-N3RM/VS –	SC-N4RM/VS –	SC-N5RM/VS –	<a href="#">Page 01/56</a>
With phase-loss protective device	Contactor Starter	– SW-N2SRM/2E	– SW-N3RM/2E	– SW-N4RM/2E	– SW-N5RM/2E	<a href="#">Page 01/64</a>
Thermal overload relay On-contactor mounting						<a href="#">Page 01/97</a>
Standard Phase-loss protection		TR-N3/3 TK-N3	TR-N3/3 TK-N3	TR-N5/3 TK-N5	TR-N5/3 TK-N5	

Frame size		N6	N7	N8	N10	Further information
Max. motor capacity (kW)	200–240V	37	45	55	65	
	380–440V	60	75	90	110	
AC-3, IEC 60947-4-1	500–550V	60	75	130	132	
	600–660V	60	90	132	132	
Operational current (A)	200–240V	125	150	180	220	
	380–440V	125	150	180	220	
	500–550V	90	120	180	200	
	600–660V	72	103	150	150	
Conventional free air thermal current (A)		150	200	260	260	
Auxiliary contact arrangement		(2NO+2NC)×2 (3NO+3NC)×2	(2NO+2NC)×2 (3NO+3NC)×2	(2NO+2NC)×2 (3NO+3NC)×2	(2NO+2NC)×2 (3NO+3NC)×2	
Standard	Contactor Starter	SC-N6RM SW-N6RM/3H	SC-N7RM SW-N7RM/3H	SC-N8RM SW-N8RM/3H	SC-N10RM SW-N10RM/3H	<a href="#">Page 01/42</a>
DC operated	Contactor Starter	SC-N6RM SW-N6RM/3H	SC-N7RM SW-N7RM/3H	SC-N8RM SW-N8RM/3H	SC-N10RM SW-N10RM/3H	<a href="#">Contact FUJI</a>
Mechanical latch AC operated	Contactor Starter	SC-N6RM/VS –	SC-N7RM/VS –	SC-N8RM/VS –	SC-N10RM/VS –	<a href="#">Page 01/56</a>
Mechanical latch DC operated	Contactor Starter	SC-N6RM/VS –	SC-N7RM/VS –	SC-N8RM/VS –	SC-N10RM/VS –	<a href="#">Page 01/56</a>
With phase-loss protective device	Contactor Starter	– SW-N6RM/2E	– SW-N7RM/2E	– SW-N8RM/2E	– SW-N10RM/2E	<a href="#">Page 01/64</a>
Thermal overload relay On-contactor mounting						<a href="#">Page 01/97</a>
Standard Phase-loss protection		TR-N6/3 TK-N6	TR-N7/3 TK-N7	TR-N8/3 TK-N8	TR-N10/3 TK-N10	

Note: Auxiliary contact arrangements indicate the ones for types except mechanical latch types.

# Magnetic Contactors and Starters

## SC and SW series

### Quick selection guide/Reversing, Open type

#### ■ Types and ratings/Reversing, Open

Frame size		N11	N12	N14	N16	Further information
Max. motor capacity (kW)	200–240V	90	120	180	–	
	380–440V	160	220	315	–	
AC-3, IEC 60947-4-1	500–550V	160	250	400	–	
	600–660V	200	300	480	–	
Operational current (A)	200–240V	300	400	600	–	
	380–440V	300	400	600	–	
	500–550V	230	360	600	–	
	600–660V	230	360	600	–	
Conventional free air thermal current (A)		350	450	660	–	
Auxiliary contact arrangement		(2NO+2NC)×2 (3NO+3NC)×2	(2NO+2NC)×2 (3NO+3NC)×2	(2NO+2NC)×2 (3NO+3NC)×2	– –	
Standard	Contactors Starters	SC-N11RM SW-N11RM/3H	SC-N12RM SW-N12RM/3H	SC-N14RM SW-N14RM/3H	– –	<a href="#">Page 01/42</a>
DC operated	Contactors Starters	SC-N11RM SW-N11RM/3H	SC-N12RM SW-N12RM/3H	SC-N14RM SW-N14RM/3H	– –	<a href="#">Contact FUJI</a>
Mechanical latch AC operated	Contactors Starters	SC-N11RM/VS –	SC-N12RM/VS –	SC-N14RM/VS –	– –	<a href="#">Page 01/56</a>
Mechanical latch DC operated	Contactors Starters	SC-N11RM/VS –	SC-N12RM/VS –	SC-N14RM/VS –	– –	<a href="#">Page 01/56</a>
With phase-loss protective device	Contactors Starters	– SW-N11RM/2E	– SW-N12RM/2E	– SW-N14RM/2E	– –	<a href="#">Page 01/64</a>
Thermal overload relay On-contactor mounting						<a href="#">Page 01/97</a>
Standard Phase-loss protection		TR-N11/3 TK-N11	TR-N12/3 TK-N12	TR-N14/3 TK-N14	– –	

Note: Auxiliary contact arrangements indicate the ones for types except mechanical latch types.

Magnetic Contactors and Starters  
**SC and SW series**  
**Quick selection guide/Reversing, Enclosed type**

■ **Types and ratings/Reversing, Enclosed**

Frame size		<b>03</b>	<b>0</b>	<b>05</b>	<b>4-0</b>	Further information
Max. motor capacity (kW)	200–240V	2.5	3.5	3.5	4.5	
	380–440V	4	5.5	5.5	7.5	
AC-3, IEC 60947-4-1	500–550V	4	5.5	5.5	7.5	
	600–660V	4	5.5	5.5	7.5	
Operational current (A)	200–240V	11	13	13	18	
	380–440V	9	12	12	16	
	500–550V	7	9	9	13	
	600–660V	5	7	7	9	
Conventional free air thermal current (A)		20	20	20	25	
Auxiliary contact arrangement		1NC×2 1NO×2	1NC×2 1NO×2	(1NO+1NC)×2 2NC×2	1NC×2 1NO×2	
Standard	Contactor Starter	SC-03RMC SW-03RMC/3H	SC-0RMC SW-0RMC/3H	SC-05RMC SW-05RMC/3H	SC-4-0RMC SW-4-0RMC/3H	<a href="#">Page 01/42</a>
With phase-loss protective device	Contactor Starter	– SW-03RMC/2E	– SW-0RMC/2E	– SW-05RMC/2E	– SW-4-0RMC/2E	<a href="#">Page 01/64</a>
With ON-OFF pushbuttons	Contactor Starter	– –	– –	– –	– –	– –
Thermal overload relay On-contactor mounting						<a href="#">Page 01/97</a>
Standard Phase-loss protection		TR-0N/3 TK-0N	TR-0N/3 TK-0N	TR-0N/3 TK-0N	TR-5-1N/3 TK-5-1N	

Frame size		<b>4-1</b>	<b>5-1</b>	<b>N1</b>	<b>N2</b>	Further information
Max. motor capacity (kW)	200–240V	5.5	5.5	7.5	11	
	380–440V	11	11	15	18.5	
AC-3, IEC 60947-4-1	500–550V	11	11	15	18.5	
	600–660V	7.5	7.5	11	15	
Operational current (A)	200–240V	22	22	32	40	
	380–440V	22	22	32	40	
	500–550V	17	17	24	29	
	600–660V	9	9	15	19	
Conventional free air thermal current (A)		32	32	50	60	
Auxiliary contact arrangement		1NC×2 1NO×2	(1NO+1NC)×2 2NC×2	(2NO+2NC)×2 (3NO+3NC)×2	(2NO+2NC)×2 (3NO+3NC)×2	
Standard	Contactor Starter	SC-4-1RMC SW-4-1RMC/3H	SC-5-1RMC SW-5-1RMC/3H	SC-N1RMC SW-N1RMC/3H	SC-N2RMC SW-N2RMC/3H	<a href="#">Page 01/42</a>
With phase-loss protective device	Contactor Starter	– SW-4-1RMC/2E	– SW-5-1RMC/2E	– SW-N1RMC/2E	– SW-N2RMC/2E	<a href="#">Page 01/64</a>
With ON-OFF pushbuttons	Contactor Starter	– –	– –	– –	– –	– –
Thermal overload relay On-contactor mounting						<a href="#">Page 01/97</a>
Standard Phase-loss protection		TR-5-1N/3 TK-5-1N	TR-5-1N/3 TK-5-1N	TR-N2/3 TK-N2	TR-N2/3 TK-N2	

# Magnetic Contactors and Starters

## SC and SW series

### Quick selection guide/Reversing, Enclosed type

#### ■ Types and ratings/Reversing, Enclosed

Frame size		N2S	N3	N4	N5	Further information
Max. motor capacity (kW)	200–240V	15	18.5	22	30	
	380–440V	22	30	40	55	
AC-3, IEC 60947-4-1	500–550V	25	37	37	55	
	600–660V	22	30	37	55	
Operational current (A)	200–240V	50	65	80	105	
	380–440V	50	65	80	105	
	500–550V	38	60	60	85	
	600–660V	26	38	44	64	
Conventional free air thermal current (A)		80	100	135	150	
Auxiliary contact arrangement		(2NO+2NC)×2 (3NO+3NC)×2	(2NO+2NC)×2 (3NO+3NC)×2	(2NO+2NC)×2 (3NO+3NC)×2	(2NO+2NC)×2 (3NO+3NC)×2	
Standard	Contactors Starter	SC-N2SRMC SW-N2SRMC/3H	SC-N3RMC SW-N3RMC/3H	SC-N4RMC SW-N4RMC/3H	SC-N5RMC SW-N5RMC/3H	Page 01/42
With phase-loss protective device	Contactors Starter	– SW-N2SRMC/2E	– SW-N3RMC/2E	– SW-N4RMC/2E	– SW-N5RMC/2E	Page 01/64
With ON-OFF pushbuttons	Contactors Starter	– –	– –	– –	– –	– –
Thermal overload relay On-contactor mounting						Page 01/97
Standard Phase-loss protection		TR-N3/3 TK-N3	TR-N3/3 TK-N3	TR-N5/3 TK-N5	TR-N5/3 TK-N5	

Frame size		N6	N7	N8	N10	Further information
Max. motor capacity (kW)	200–240V	37	45	55	65	
	380–440V	60	75	90	110	
AC-3, IEC 60947-4-1	500–550V	60	75	130	132	
	600–660V	60	90	132	132	
Operational current (A)	200–240V	125	150	180	220	
	380–440V	125	150	180	220	
	500–550V	90	120	180	200	
	600–660V	72	103	150	150	
Conventional free air thermal current (A)		150	200	260	260	
Auxiliary contact arrangement		(2NO+2NC)×2 (3NO+3NC)×2	(2NO+2NC)×2 (3NO+3NC)×2	(2NO+2NC)×2 (3NO+3NC)×2	(2NO+2NC)×2 (3NO+3NC)×2	
Standard	Contactors Starter	SC-N6RMC SW-N6RMC/3H	SC-N7RMC SW-N7RMC/3H	SC-N8RMC SW-N8RMC/3H	SC-N10RMC SW-N10RMC/3H	Page 01/42
With phase-loss protective device	Contactors Starter	– SW-N6RMC/2E	– SW-N7RMC/2E	– SW-N8RMC/2E	– SW-N10RMC/2E	Page 01/64
With ON-OFF pushbuttons	Contactors Starter	– –	– –	– –	– –	– –
Thermal overload relay On-contactor mounting						Page 01/97
Standard Phase-loss protection		TR-N6/3 TK-N6	TR-N7/3 TK-N7	TR-N8/3 TK-N8	TR-N10/3 TK-N10	

■ **Types number nomenclature**

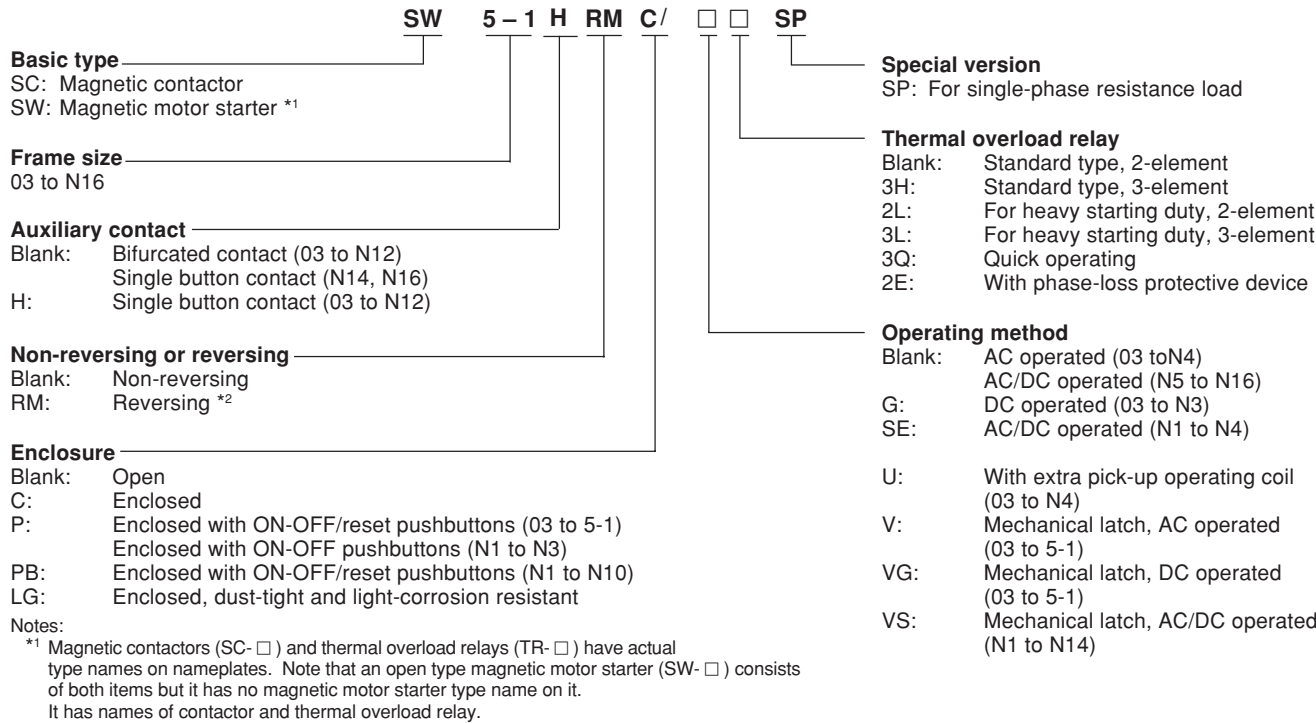

• **Example**

When a motor starter SW-0 is ordered;



\*2 Open type reversing magnetic contactors (SC- □RM) and motor starters (SW- □ RM) have no type name on their nameplates describing them as reversing types.

• **Example**

When a reversing contactor SC-0RM is ordered;

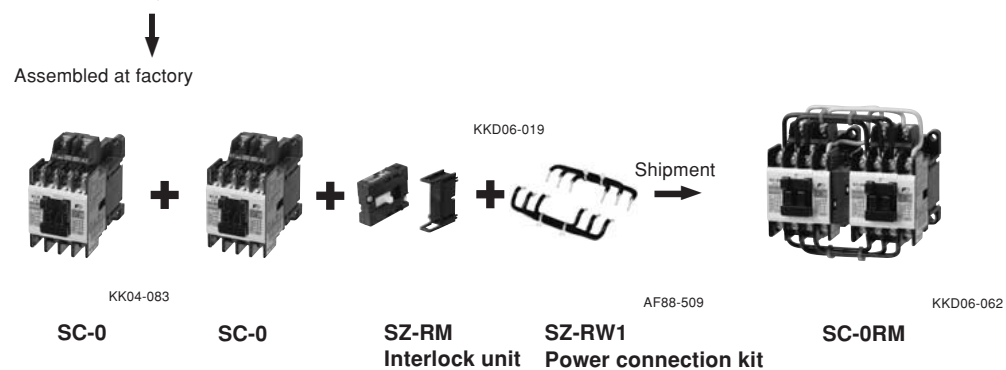

■ **Ordering information**

Specify the following:

1. Ordering code (see next page)
2. Overload relay setting range code
3. Operating coil voltage code
4. Auxiliary contact arrangement code

# Magnetic Contactors and Starters

## SC and SW series

### Ordering code system

#### ■ Ordering code system

SC series magnetic contactors

SC 25 B A A-M 22  
①② ③④ ⑤ ⑥ ⑦ ⑧ ⑨ ⑩⑪

SW series magnetic motor starter

SC 25 B A A N-M 22 TB D  
①② ③④ ⑤ ⑥ ⑦ ⑧ ⑨ ⑩⑪ ⑫ ⑬

#### ① Product category

Description	Code
Contactors and starters	S

#### ② Series category

Description	Code
SC and SW series	C

#### ③④ Frame size

Frame size	Code	
	③	④
03	1	1
0	1	3
05	1	4
4-0	1	8
4-1	1	9
5-1	2	0
N1	2	5
N2	3	5
N2S	5	0
N3	6	5
N4	8	0
N5	9	3
N6	1	C
N7	1	F
N8	1	J
N10	2	C
N11	3	A
N12	4	A
N14	6	A
N16*	8	A

\*Contactor only

#### ⑤ Index

Index	Code
03 to 5-1	Blank
N1 to N16	B

#### ⑨ Coil voltage

##### ● Frame size 03 to N4 AC coil

Operating coil voltage	Code	
	50Hz	60Hz
24V	24-26V	E
48V	48-52V	F
100V	100-110V	1
100-110V	110-120V	H
110-120V	120-130V	K
200V	200-220V	2
200-220V	220-240V	M
220-240V	240-260V	P
346-380V	380-420V	S
380-400V	400-440V	4
415-440V	440-480V	T
480-500V	500-550V	5

#### ⑥ Version

Description	Code	
	Contactor	Starter
<u>Non-reversing, open</u> Standard	A	A
<u>Non-reversing, enclosed</u> Standard Dust-tight/light-corrosion resistant With on – off pushbutton With on – off/reset pushbutton	C – – –	C L P J
<u>Reversing, open</u> Standard	R	R
<u>Reversing, enclosed</u> Standard Dust-tight/light-corrosion resistant	M –	M G

#### ⑦ Coil and contact specifications

Description	Code
Standard	AC operating coil DC operating coil Both AC and DC operating coil With extra pick-up operating coil
With super magnet	Both AC and DC operating coil
Mechanical latch (Contactor only)	AC operating coil DC operating coil Both AC and DC operating coil
With single-button auxiliary contact	AC operating coil DC operating coil With extra pick-up operating coil

#### ⑧ Type of thermal overload relay

Description	Code
Standard	TR-□ 2-element TR-□/3 3-element
Long time operating	TR-□L 2-element TR-□L3 3-element
Quick operating	TR-□Q 3-element
Open-phase protection	TK-□ 3-element

##### ● Frame size 03 to N3 DC coil

Operating coil voltage	Code
12V DC	B
24V DC	E
48V DC	F
60V DC	G
100V DC	1
110V DC	H
120V DC	K
200V DC	2
210V DC	Y
220V DC	M

##### ● Frame size N1/SE to N4/SE, N5 to N16 AC and DC coil (common)

Operating coil voltage	Code	
	AC 50/60Hz	DC
24-25V	24V	E
48-50V	48V	F
100-127V	100-120V	1
200-250V	200-240V	2
265-347V	–	3
380-450V	–	4
460-575V	–	5

⑩⑪ **Auxiliary contact**

● **SC-03 to 5-1**

Contact arrangement	Code	
	⑨	⑩
1NO	1	0
1NC	0	1
1NO+1NC	1	1
2NO	2	0
2NC	0	2
2NO+2NC	2	2

● **SC-N1 to N16**

Contact arrangement	Code	
	⑨	⑩
2NO+2NC	2	2
3NO+3NC	3	3
4NO+4NC	4	4

⑬ **No. of heater element and reset method**

Description	Code
Manual reset	Blank
2-element	
3-element	D
Auto reset	A
2-element	
3-element	

■ **Correct mounting**

- (1) The standard mounting shown in Figure 1 is the proper mounting method. Following slanting mounting with front, behind, left and right direction is possible. (Figure 2) Allowable slant angle of SC (SW) - 03 to N16 : 30°
- (2) Side mounting can be necessary due to wiring or installation restriction. Side mounting is possible if you consider the followings, except for the types of SC-N14, 16 and mechanically latched type.
  - The performance of magnetic contactors is almost the same. Only mechanical durability and switching frequency may decrease.
  - The ultimate operational current of thermal overload relay may slightly changes.
- (3) Other mountings
  - Standard magnetic contactors and starters cannot be mounted on the ceiling. If they were mounted on the ceiling, they could not satisfy the operating performance value specified by Standards due to effect of moving section mass.
  - Standard magnetic contactors and starters cannot be mounted horizontally. External vibration or shock may result in malfunction due to effect of moving section mass. Dedicated horizontal mounting models are available on request. Add suffix "Z109" to the type number when

⑫ **Thermal overload relay ampere setting range**

Ampere setting range (A)	Code	Ampere setting range (A)	Code	Ampere setting range (A)	Code
0.1 - 0.15	TA	4 - 6	TS	65 - 95	TM
0.13 - 0.2	TB	5 - 8	TT	85 - 105	TI
0.15 - 0.24	TC	6 - 9	TU	85 - 125	TN
0.2 - 0.3	TD	7 - 11	TV	110 - 160	TP
0.24 - 0.36	TE	9 - 13	TW	125 - 185	TR
0.3 - 0.45	TF	12 - 18	TX	160 - 240	TS
0.36 - 0.54	TG	16 - 22	TQ	200 - 300	TT
0.48 - 0.72	TH	18 - 26	TB	240 - 360	TU
0.64 - 0.96	TJ	24 - 36	TE	300 - 450	TV
0.8 - 1.2	TK	28 - 40	TF	400 - 600	TW
0.95 - 1.45	TL	32 - 42	TI		
1.4 - 2.2	TM	34 - 50	TG		
1.7 - 2.6	TN	45 - 65	TJ		
2.2 - 3.4	TP	48 - 68	TO		
2.8 - 4.2	TR	53 - 80	TL		

**Ordering example**

● **Magnetic motor starter**

①	Magnetic starter .....	S
②	SW series .....	C
③④	Frame size: 5-1 .....	20
⑤	Index .....	Blank
⑥	Non-reversing, open: Standard .....	A
⑦	Operating coil: AC operating .....	A
⑧	Thermal overload relay: Standard .....	N
⑨	Operating coil voltage: 220V-240V AC, 50Hz .....	P
⑩⑪	Auxiliary contact: 1NO+1NC .....	11
⑫	Thermal overload relay heater range : 9-13 .....	TW
⑬	No. of heater element: 3 .....	D

Ordering code: SC20AAN-P11TWD

● **Magnetic contactor**

①	Magnetic contactor .....	S
②	SC series .....	C
③④	Frame size: N5 .....	93
⑤	Index .....	B
⑥	Non-reversing, open: Standard .....	A
⑦	Operating coil: DC operating .....	A
⑨	Operating coil voltage: 110V DC .....	1
⑩⑪	Auxiliary contact: 2NO+2NC .....	22

Ordering code: SC93BAA-122

ordering. However, the models of "Z109" specification cannot be applied to standard mounting (vertical mounting).

- (i) Dedicated horizontal mounting models have 80% of mechanical durability, electrical durability and switching frequency, compared with standard mounting models.
- (ii) For magnetic starters, the ultimate operational current of thermal overload relay slightly changes.
- (iii) The following models are available; type SC-03 to SC-5-1, type SW-03 to 5-1, type SH-4, 5, type SC-N1 to N10, type SW-N1 to N10, type SC-N1/G to N3/G, type SC-N1/SE to N4/SE, type SB-□N.
- (iv) Dedicated horizontal mounting models of type SC-03/G to SC-5-1/G, type SC-N11 to SC-N16, type SB-□NB are not available.

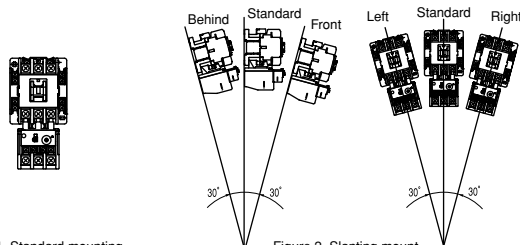

Figure 1 Standard mounting

Figure 2 Slanting mount

# Magnetic Contactors and Starters

## SC and SW series

### Specifications

#### ■ Ratings

Conforming to IEC 60947-4-1, EN 60947-4-1, VDE 0660

Contactor Type	Starter Type	Max. motor capacity (kW)				Rated operational current (A)				Thermal current (A) *1
		200V   240V	380V   440V	500V   550V	600V   660V	200V   240V	380V   440V	500V   550V	600V   660V	
SC-03	SW-03/3H	2.5	4	4	4	11	9	7	5	20
SC-0	SW-0/3H	3.5	5.5	5.5	5.5	13	12	9	7	20
SC-05	SW-05/3H	3.5	5.5	5.5	5.5	13	12	9	7	20
SC-4-0	SW-4-0/3H	4.5	7.5	7.5	7.5	18	16	13	9	25
SC-4-1	SW-4-1/3H	5.5	11	11	7.5	22	22	17	9	32
SC-5-1	SW-5-1/3H	5.5	11	11	7.5	22	22	17	9	32
SC-N1	SW-N1/3H	7.5	15	15	11	32	32	24	15	50
SC-N2	SW-N2/3H	11	18.5	18.5	15	40	40	29	19	60
SC-N2S	SW-N2S/3H	15	22	25	22	50	50	38	26	80
SC-N3	SW-N3/3H	18.5	30	37	30	65	65	60	38	100
SC-N4	SW-N4/3H	22	40	37	37	80	80	60	44	135
SC-N5	SW-N5/3H	30	55	55	55	105	105	85	64	150
SC-N6	SW-N6/3H	37	60	60	60	125	125	90	72	150
SC-N7	SW-N7/3H	45	75	75	90	150	150	120	103	200
SC-N8	SW-N8/3H	55	90	130	132	180	180	180	150	260
SC-N10	SW-N10/3H	65	110	132	132	220	220	200	150	260
SC-N11	SW-N11/3H	90	160	160	200	300	300	230	230	350
SC-N12	SW-N12/3H	120	220	250	300	400	400	360	360	450
SC-N14	SW-N14/3H	180	315	400	480	600	600	600	600	660
SC-N16	—	220	440	500	500	800	800	720	630	800

Note: \*1 The values are applied to contactors.

#### ■ Making and breaking capacities

Utilization category	Typical applications	IEC 60947-4-1, EN 60947-4-1, VDE 0660, JIS C 8201-4-1						
		Making and breaking			Making			
		Ic/Ie	Ur/Ue	cosφ or L/R	I/Ie	U/Ue	cosφ or L/R	
AC-1	Non-inductive or slightly inductive loads, resistance furnaces	1.5	1.05	0.8	1.5	1.05	0.8	
AC-2	Slip-ring motors: Starting, switching off	4.0	1.05	0.65	4.0	1.05	0.65	
AC-3	Squirrel-cage motors: Starting, switching off during running	Ie 100A	8.0	1.05	0.45	10	1.05	0.45
		Ie > 100A	8.0	1.05	0.35	10	1.05	0.35
AC-4	Squirrel-cage motors: Starting, plugging, inching	Ie 100A	10	1.05	0.45	12	1.05	0.45
		Ie > 100A	10	1.05	0.35	12	1.05	0.35
AC-5a	Switching of electric discharge lamp controls	3.0	1.05	0.45	3.0	1.05	0.45	
AC-5b	Switching of incandescent lamps	1.5	1.05	*	1.5	1.05	*	

Note: \*Test to be carried out with an incandescent lamp load.

Ie: Rated operational current

Ue: Rated operational voltage

I: Current made

U: Voltage before make

Ur: Recovery voltage

Ic: Current broken

#### ■ Auxiliary contact ratings

Conforming to IEC 60947-5-1, EN 60947-5-1, VDE 0660

Type	Continuous current (A)	Make and break capacity at AC (A)	Rated operational current (A)						Minimum voltage and current
			AC Voltage (V)	AC-15 (Ind.load)	AC-12 (Res.load)	DC Voltage (V)	DC-13 (Ind.load)	DC-12 (Res.load)	
SC-03 to SC-N12	10	60	100–120	6	10	24	3	5	5V 3mA
		30	200–240	3	8	48	1.5	3	
		15	380–440	1.5	5	110	0.55	2.5	
		12	500–600	1.2	5	220	0.27	1	
SC-N14 to SC-16N	10	60	100–120	6	10	24	5	10	24V 10mA
		60	200–240	6	10	48	1.5	5	
		40	380–440	4	10	110	0.55	2.5	
		25	500–600	2.5	10	220	0.27	1	



**■ Inching and plugging operations  
(Conforming to IEC 60947-4-1)**

In applications where inching and plugging operations are included the contact wear will be increased. Therefore, it is necessary to select ones having larger frame sizes than in standard applications so as to minimize the needs of maintenance and replacement.

Voltage	Motor ratings		50% inching operation	
	Capacity (kW)	Full load current (A)	Electrical durability 100,000 operations	Electrical durability 500,000 operations
200V   240V	0.2	1.8	SC-03	SC-03
	0.4	3.2	SC-03	SC-03
	0.75	4.8	SC-03	SC-0, 05
	1.5	8.0	SC-03	SC-4-1, 5-1
	2.2	11.1	SC-4-0	SC-N1
	3.7	17.4	SC-4-1, 5-1	SC-N2
	5.5	26	SC-N1	SC-N3
	7.5	34	SC-N2	SC-N5
	11	48	SC-N2S	SC-N7
	15	65	SC-N4	SC-N8
380V   440V	18.5	79	SC-N5	SC-N10
	22	93	SC-N6	SC-N11
	30	124	SC-N7	SC-N14
	37	152	SC-N8	SC-N14
	45	180	SC-N10	—
	55	220	SC-N11	—
	75	300	SC-N14	—
	0.75	2.4	SC-03	SC-03
	1.5	4.0	SC-03	SC-03
	2.2	5.6	SC-03	SC-4-0
3.7	8.7	SC-03	SC-4-1, 5-1	
5.5	13	SC-4-0	SC-N1	
7.5	17	SC-4-1, 5-1	SC-N2S	
11	24	SC-N1	SC-N3	
15	32.5	SC-N2	SC-N5	
18.5	39.5	SC-N2S	SC-N6	
22	46.5	SC-N3	SC-N7	
30	62	SC-N4	SC-N8	
37	76	SC-N5	SC-N10	
45	90	SC-N6	SC-N11	
55	110	SC-N8	SC-N12	
75	150	SC-N10	SC-N14	
90	180	SC-N11	—	
110	220	SC-N12	—	
132	264	SC-N14	—	
150	300	SC-N14	—	
160	320	SC-N14	—	

Notes: 1. Inching % =  $\frac{\text{No. of inching operations}}{\text{Total No. of switching operations}} \times 100\%$

2. Light inching: 50%  
 Printing machine and similar equipment  
 Heavy inching: 75 – 100%  
 Machine tool, hoist and similar equipment (In cases when there are frequent on/off operations involving starting rush current).

**■ Standard conditions for operation in service**

- Temperature range:  
 Operating: -5°C to +40°C  
 (-5°C to + 55°C inside panel box)  
 Storage: -40°C to + 65°C
- Humidity: 45 to 85% RH
- Vibration: 10 to 55Hz, 15m/s<sup>2</sup>
- Shock: 50m/s<sup>2</sup>
- Altitude: 2000m (6600ft) or lower
- IP40

**■ Breaking current and electrical durability  
SC-03 to 5-1**

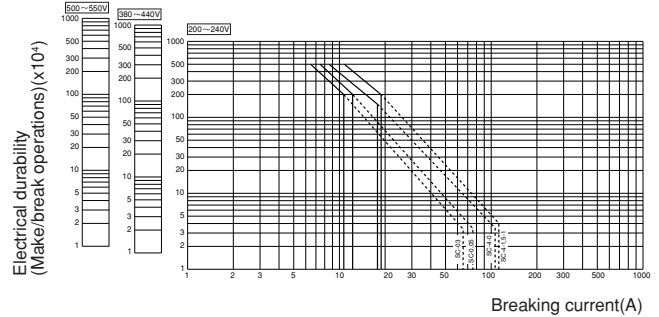

**SC-N1 to N3**

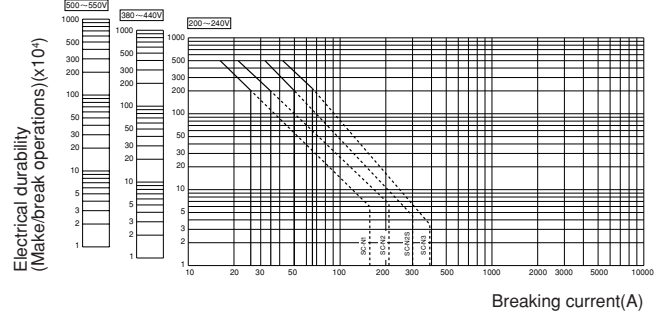

**SC-N4 to N16**

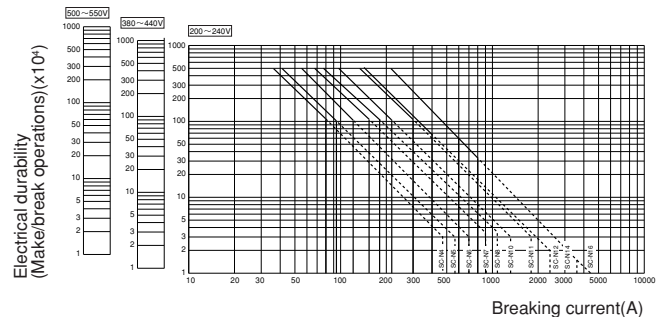

**■ Testing method—Category AC-3**

The method of determining the life expectancy and performance is prescribed by IEC as below.

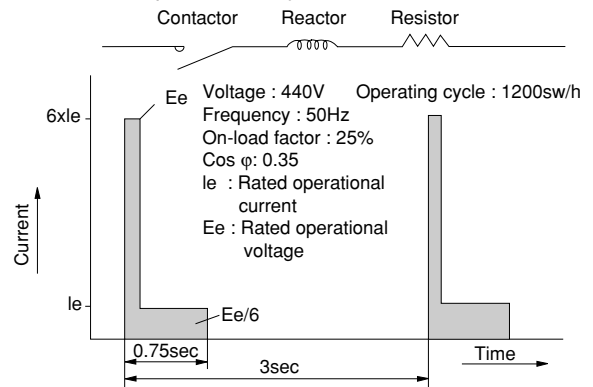

A current equal to six times that of the rated operational current of the starter is applied to the terminals the switch is closed and the current immediately reduced to the rated operational current and then interrupted.

# Magnetic Contactors and Starters

## SC and SW series

### Specifications

#### ■ Performance data

Frame size	Making capacity I/le	Breaking capacity I/le	Operating cycles per hour	Voltage	Durability (operations)	
					Electrical *	Mechanical
<b>03, 0, 05</b>	12	10	1,800	200/240V AC 380/440V AC	2 million	10 million
<b>4-0</b>	12	10	1,800	200/240V AC 380/440V AC	1.5 million	10 million
<b>4-1, 5-1</b>	12	10	1,800	200/240V AC 380/440V AC	2 million	10 million
<b>N1 to N3</b>	12	10	1,200	200/240V AC 380/440V AC	2 million	10 million (N1, N2) 5 million (N2S, N3)
<b>N4 to N11</b>	12	10	1,200	200/240V AC 380/440V AC	1 million	5 million
<b>N12, N14</b>	12	10	1,200	200/240V AC 380/440V AC	500,000	5 million
<b>N16</b>	12	10	1,200	200/240V AC 380/440V AC	250,000	2.5 million

Ie: Rated operational current. I: Making or breaking current \* For details, refer to [page 01/29](#)

#### ■ Coil voltage

##### ● Frame size 03 to N4

Frame size	Coil operating voltage and frequency (AC)			Order voltage	Coil voltage code	Identification by coil color	Wiring
<b>03</b>	24V	50Hz/24–26V	60Hz	AC24V	<b>E</b>	White	
<b>0</b>	48V	50Hz/48–52V	60Hz	AC48V	<b>F</b>	White	
<b>05</b>	100V	50Hz/100–110V	60Hz	AC100V	<b>1</b>	Green (Standard voltage)	
<b>4-0</b>	100–110V	50Hz/110–120V	60Hz	AC110V	<b>H</b>	White	
<b>4-1</b>	110–120V	50Hz/120–130V	60Hz	AC120V	<b>K</b>	White	
<b>5-1</b>	200V	50Hz/200–220V	60Hz	AC200V	<b>2</b>	Yellow (Standard voltage)	
<b>N1</b>	200–220V	50Hz/220–240V	60Hz	AC220V	<b>M</b>	White	
<b>N2</b>	220–240V	50Hz/240–260V	60Hz	AC240V	<b>P</b>	White	
<b>N2S</b>	346–380V	50Hz/380–420V	60Hz	AC380V	<b>S</b>	White	
<b>N3</b>	380–400V	50Hz/400–440V	60Hz	AC400V	<b>4</b>	Purple (Standard voltage)	
<b>N4</b>	415–440V	50Hz/440–480V	60Hz	AC440V	<b>T</b>	White	
	480–500V	50Hz/500–550V	60Hz	AC500V	<b>5</b>	White	

Notes: • Other voltages are available in 24 to 600V ranges on request.  
 • For frame size N1/SE to N4/SE, 24V to 250V AC (24V to 240V DC) is available.  
 • Use the coil voltage code, not specifying your actual voltage when ordering. Contactors with coil voltage range which corresponds to the voltage code you specified will be shipped from factory.  
 The above coil operating voltage and frequency (not voltage code) are shown on the products.

##### ● Frame size N5 to N16

Frame size	Coil operating voltage and frequency		Order voltage	Coil voltage code	Identification by coil color	Wiring
	AC	DC				
<b>N5</b>	24–25V 50/60Hz	24V	AC24V <sup>*3</sup>	<b>E</b>	White	
<b>N6</b>	48–50V 50/60Hz	48V	AC48V <sup>*3</sup>	<b>F</b>	White	
<b>N7</b>	100–127V 50/60Hz	100–120V <sup>*1</sup>	AC100V	<b>1</b>	Green (Standard voltage)	
<b>N8</b>						
<b>N10</b>	200–250V 50/60Hz	200–240V <sup>*2</sup>	AC200V	<b>2</b>	Yellow (Standard voltage)	
<b>N11</b>	265–347V 50/60Hz	–	AC300V	<b>3</b>	White	
<b>N12</b>	380–450V 50/60Hz	–	AC400V	<b>4</b>	Purple (Standard voltage)	
<b>N14</b>	460–575V 50/60Hz	–	AC500V	<b>5</b>	White	
<b>N16</b>						

Notes: • The coils are AC/DC common use (rated voltage 200V or less)  
 • Standard rated voltages are 100V, 200V and 400V.  
 Other voltages are available in 24V to 575V AC (24V to 240V DC) in frame size N5 to N12, also available in 100V to 575V AC (100V to 240V DC) in frame size N14 to N16.  
 • Use the coil voltage code, not specifying your actual voltage when ordering. Contactors with coil voltage range which corresponds to the voltage code you specified will be shipped from factory.  
 The above coil operating voltage and frequency (not voltage code) are shown on the products.  
<sup>\*1</sup> The coil voltage from a DC power supply with single phase full-wave rectification will be 100 to 110 V.  
<sup>\*2</sup> The coil voltage from a DC power supply with single phase full-wave rectification will be 200 to 220 V.  
<sup>\*3</sup> The coil voltage 24V and 48V are not available in frame size N14 to N16.

■ Coil characteristics  
● Frame size 03 to N4

Frame size	Power consumption		Watt loss (W)		Pick-up voltage (V)		Drop-out voltage (V)		Operating time (ms)	
	Inrush (VA)	Sealed (VA)	200V 50Hz	220V 60Hz	200V 50Hz	220V 60Hz	200V 50Hz	220V 60Hz	Coil ON→ Contact ON	Coil OFF→ Contact OFF
<b>03</b>	95	9	2.7	2.8	105-125	116-136	70-98	80-110	9-20	5-16
<b>0</b>	95	9	2.7	2.8	105-125	116-136	70-98	80-110	9-20	5-16
<b>05</b>	95	9	2.7	2.8	105-125	116-136	70-98	80-110	9-20	5-16
<b>4-0</b>	95	9	2.7	2.8	118-136	130-146	75-106	88-120	9-20	5-16
<b>4-1</b>	95	9	2.7	2.8	118-136	130-146	75-106	88-120	9-20	5-16
<b>5-1</b>	95	9	2.7	2.8	118-136	130-146	75-106	88-120	9-20	5-16
<b>N1</b>	135	12.7	3.6	3.8	110-130	120-140	75-105	85-115	10-17	6-17
<b>N2</b>	135	12.7	3.6	3.8	110-130	120-140	75-105	85-115	10-17	6-17
<b>N2S</b>	190	13.4	4.5	5	115-135	130-150	85-110	100-125	10-18	8-18
<b>N3</b>	190	13.4	4.5	5	115-135	130-150	85-110	100-125	10-18	8-18
<b>N4</b>	210	14.4	4.8	5.3	120-140	135-155	70-95	95-120	16-23	7-17

Note: Coil ratings 200V 50Hz, 200 to 220V 60Hz. Operating time is based on 200V 50Hz.

● Frame size N5 to N16, N1/SE to N4/SE (contactor only)

AC operating

Frame size	Power consumption		Watt loss (W)		Pick-up voltage (V) 200V 50/60Hz	Drop-out voltage (V) 200V 50/60Hz	Operating time (ms)	
	Inrush (VA)	Sealed (VA)	200V 50Hz	220V 60Hz			Coil ON→ Contact ON	Coil OFF→ Contact OFF
<b>N5</b>	95	4.6	3.2	3.6	140-150	60-100	39-45	27-33
<b>N6</b>	230	5.8	3.4	3.7	140-150	60-100	31-37	30-36
<b>N7</b>	230	5.8	3.4	3.7	140-150	60-100	31-37	30-36
<b>N8</b>	255	6.2	4.7	5.2	140-150	60-100	38-44	31-37
<b>N10</b>	255	6.2	4.7	5.2	140-150	60-100	38-44	31-37
<b>N11</b>	320	6.5	5.6	6	140-150	60-100	43-49	41-47
<b>N12</b>	320	6.5	5.6	6	140-150	60-100	43-49	41-47
<b>N14</b>	460	11	7.8	8.6	140-160	60-100	69-75	56-62
<b>N16</b>	460	11	7.8	8.6	140-160	60-100	69-75	56-62
<b>N1/SE</b>	130	4.2	2.8	3.2	140-150	60-100	21-27	18-24
<b>N2/SE</b>	130	4.2	2.8	3.2	140-150	60-100	21-27	18-24
<b>N2S/SE</b>	160	4.3	2.9	3.3	140-150	60-100	24-30	24-32
<b>N3/SE</b>	160	4.3	2.9	3.3	140-150	60-100	24-30	24-32
<b>N4/SE</b>	95	4.6	3.2	3.6	140-150	60-100	39-45	26-33

Note: Coil ratings 200 to 250V 50/60Hz, 200 to 220V DC. Operating time is based on 200V 50/60Hz.

DC operating

Frame size	Power consumption		Time constant (ms) Sealed	Pick-up voltage (V) 200V DC	Drop-out voltage (V) 200V DC	Operating time (ms)	
	Inrush (W)	Sealed (W)				Coil ON→ Contact ON	Coil OFF→ Contact OFF
<b>N5</b>	110	3	1	140-160	40-100	35-41	26-32
<b>N6</b>	275	4	1	140-160	40-100	28-34	27-33
<b>N7</b>	275	4	1	140-160	40-100	28-34	27-33
<b>N8</b>	300	4.5	1	140-160	40-100	33-39	31-37
<b>N10</b>	300	4.5	1	140-160	40-100	33-39	31-37
<b>N11</b>	410	4.6	1	140-160	40-100	38-44	41-47
<b>N12</b>	410	4.6	1	140-160	40-100	38-44	41-47
<b>N14</b>	500	8.8	1	140-160	40-100	64-70	52-57
<b>N16</b>	500	8.8	1	140-160	40-100	64-70	52-57

Note: Coil ratings 200 to 250V 50/60Hz, 200 to 220V DC. Operating time is based on 200V DC.

# Magnetic Contactors and Starters

## SC and SW series

### Specifications

#### DC applications of magnetic contactors

##### ■ Description

FUJI magnetic contactors in the SC series are normally used in AC circuit applications. However, they may also be used in DC circuits, and in this case their contacts must be connected in series as shown in the diagram.

When used in this manner they will be found to be more economical than using contactors exclusively designed for DC applications. Coils are available for both AC and DC.

If the following ratings are observed the equipment will have an electrical durability of approx. 500,000 operations.

##### ■ Wiring connection

Contacts must be connected in series when the contactors are used in DC applications.

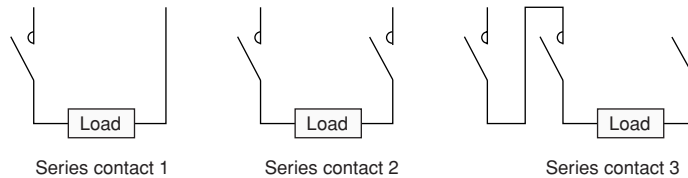

##### ■ Ratings

Type	No. of contacts connected in series	Rated operational current (A)							
		Class DC-1(JEM1038) (Resistive, L/R ≤ 1ms.)				Class DC2, 4,(JEM1038) (DC motor, L/R ≤ 15ms.)			
		24V	48V	110V	220V	24V	48V	110V	220V
SC-03	1	13	13	10	1.2	6	3	2	0.35
	2	13	13	10	6	12	6	4	1.2
	3	15	15	15	15	15	10	8	4
SC-0	1	13	13	10	1.2	6	3	2	0.35
	2	13	13	10	6	12	6	4	1.2
	3	15	15	15	15	15	10	8	4
SC-05	1	13	13	10	1.2	6	3	2	0.35
	2	13	13	10	6	12	6	4	1.2
	3	15	15	15	15	15	10	8	4
SC-4-0	1	16	13	10	1.5	8	6	2	0.35
	2	16	16	12	8	16	12	6	1.5
	3	18	18	18	15	18	18	12	6
SC-4-1	1	20	15	12	2	10	8	3	0.35
	2	20	20	15	10	20	15	8	2
	3	22	22	20	15	22	22	15	8
SC-5-1	1	20	15	12	2	10	8	3	0.35
	2	20	20	15	10	20	15	8	2
	3	22	22	20	15	22	22	15	8
SC-N1	1	25	25	15	2	15	8	3	0.35
	2	25	25	25	20	25	15	8	2
	3	35	35	30	25	35	25	20	8
SC-N2	1	30	30	20	2	20	15	4	0.35
	2	30	30	30	20	30	20	15	3
	3	45	45	40	35	35	30	30	8
SC-N2S	2	60	60	40	20	60	30	20	3.5
	3	60	60	60	40	60	60	60	13
SC-N3	2	80	80	50	20	80	40	20	4
	3	80	80	80	60	80	80	80	20
SC-N4	2	80	80	50	20	80	40	20	4
	3	80	80	80	60	80	80	80	20
SC-N5	2	120	120	80	40	120	80	40	15
	3	120	120	120	120	120	120	120	80
SC-N6	2	120	120	80	40	120	80	40	15
	3	120	120	120	120	120	120	120	80
SC-N7	2	160	160	100	80	160	120	80	40
	3	160	160	160	160	160	160	160	160
SC-N8	2	200	200	160	160	200	160	120	60
	3	200	200	200	200	200	200	200	200
SC-N10	2	200	200	160	160	200	160	120	60
	3	200	200	200	200	200	200	200	200
SC-N11	2	300	300	200	200	300	200	160	80
	3	300	300	300	300	300	300	300	300
SC-N12	2	400	400	330	300	400	300	200	100
	3	400	400	400	400	400	400	400	400
SC-N14	2	600	500	420	300	-	-	-	-
	3	600	600	600	420	-	-	-	-

**Standard type non-reversing contactors and starters**

Up to 315kW 440 Volts 3-phase  
(440kW for contactor only)

**Description**

The starter consists of a magnetic contactor and a thermal overload relay and is designed for the full voltage starting of 3-phase induction motor.

**Standards**

- Meet the requirements of BS, NEMA, IEC, VDE and JIS.
- The SC series contactors have already been approved by NK, LR, BV for marine use, UL, CSA and TÜV. These contactors can be used universally because of their high efficiency and reliability and are completely safe. Their maximum rated voltage is 660V AC.

**Features**

**SC-03 to SC-5-1**

- Small frame contactors have such options as additional auxiliary blocks, operation counter unit with snap-on fittings, and coil surge suppressors. Modification can be made quickly and easily on site.
- Bifurcated type auxiliary contacts have a high degree of contact reliability. They can be used in low level circuit of 5V, 3mA.
- Type and rating are indicated on the front of contactor.

**Contactors with single button auxiliary contacts (SC-03H to N12H)**

[See page 01/72](#)

**Types and ratings**

Max. motor capacity (kW)		Rated operation current (A)		Rated thermal current (A)	Auxiliary contact		Contactor		Starter (3-element)			
200V	380V 240V 440V	200V	380V 240V 440V		NO	NC	Open Type	Ordering code	Open Type	Ordering code	Enclosed Type	Ordering code
2.5	4	11	9	20	1	—*1	SC-03	SC11AA-■10	SW-03/3H	SC11AAN-■10□□	SW-03C/3H	SC11CAN-■10□□
3.5	5.5	13	12	20	1	—*1	SC-0	SC13AA-■10	SW-0/3H	SC13AAN-■10□□	SW-0C/3H	SC13CAN-■10□□
3.5	5.5	13	12	20	1	1*2	SC-05	SC14AA-■11	SW-05/3H	SC14AAN-■11□□	SW-05C/3H	SC14CAN-■11□□
4.5	7.5	18	16	25	1	—*1	SC-4-0	SC18AA-■10	SW-4-0/3H	SC18AAN-■10□□	SW-4-0C/3H	SC18CAN-■10□□
5.5	11	22	22	32	1	—*1	SC-4-1	SC19AA-■10	SW-4-1/3H	SC19AAN-■10□□	SW-4-1C/3H	SC19CAN-■10□□
5.5	11	22	22	32	1	1*3	SC-5-1	SC20AA-■11	SW-5-1/3H	SC20AAN-■11□□	SW-5-1C/3H	SC20CAN-■11□□
7.5	15	32	32	50	2	2	SC-N1	SC25BAA-■22	SW-N1/3H	SC25BAAN-■22□□	SW-N1C/3H	SC25BCAN-■22□□
11	18.5	40	40	60	2	2	SC-N2	SC35BAA-■22	SW-N2/3H	SC35BAAN-■22□□	SW-N2C/3H	SC35BCAN-■22□□
15	22	50	50	80	2	2	SC-N2S	SC50BAA-■22	SW-N2S/3H	SC50BAAN-■22□□	SW-N2SC/3H	SC50BCAN-■22□□
18.5	30	65	65	100	2	2	SC-N3	SC65BAA-■22	SW-N3/3H	SC65BAAN-■22□□	SW-N3C/3H	SC65BCAN-■22□□
22	40	80	80	135	2	2	SC-N4	SC80BAA-■22	SW-N4/3H	SC80BAAN-■22□□	SW-N4C/3H	SC80BCAN-■22□□
30	55	105	105	150	2	2	SC-N5	SC93BAA-■22	SW-N5/3H	SC93BAAN-■22□□	SW-N5C/3H	SC93BCAN-■22□□
37	60	125	125	150	2	2	SC-N6	SC1CBAA-■22	SW-N6/3H	SC1CBAAN-■22□□	SW-N6C/3H	SC1CBCAN-■22□□
45	75	150	150	200	2	2	SC-N7	SC1FBAA-■22	SW-N7/3H	SC1FBAAN-■22□□	SW-N7C/3H	SC1FBCAN-■22□□
55	90	180	180	260	2	2	SC-N8	SC1JBAA-■22	SW-N8/3H	SC1JBAAN-■22□□	SW-N8C/3H	SC1JBCAN-■22□□
65	110	220	220	260	2	2	SC-N10	SC2CBAA-■22	SW-N10/3H	SC2CBAAN-■22□□	SW-N10C/3H	SC2CBCAN-■22□□
90	160	300	300	350	2	2	SC-N11	SC3ABAA-■22	SW-N11/3H	SC3ABAAN-■22□□	SW-N11C/3H	SC3ABCAN-■22□□
120	220	400	400	450	2	2	SC-N12	SC4ABAA-■22	SW-N12/3H	SC4ABAAN-■22□□	SW-N12C/3H	SC4ABCAN-■22□□
180	315	600	600	660	2	2	SC-N14	SC6ABAA-■22	SW-N14/3H	SC6ABAAN-■22□□	SW-N14C/3H	SC6ABCAN-■22□□
220	440	800	800	800	2	2	SC-N16	SC8ABAA-■22				

Notes : 1. ■ : Coil voltage code, □ : Thermal overload relay ampere setting range code, [see page 01/27](#).

2. \*1 Auxiliary contact 1NC is available. \*2 Auxiliary contact 2NC or 2NC is available.

\*3 Auxiliary contact 2NO, 2NC, or 2NO+2NC is available. For enclosed type, 2NO+2NC is not available.

3. Auxiliary contact 4NO+4NC is available on request for frame size N1 and above.

4. Contactor with enclosure is also available.

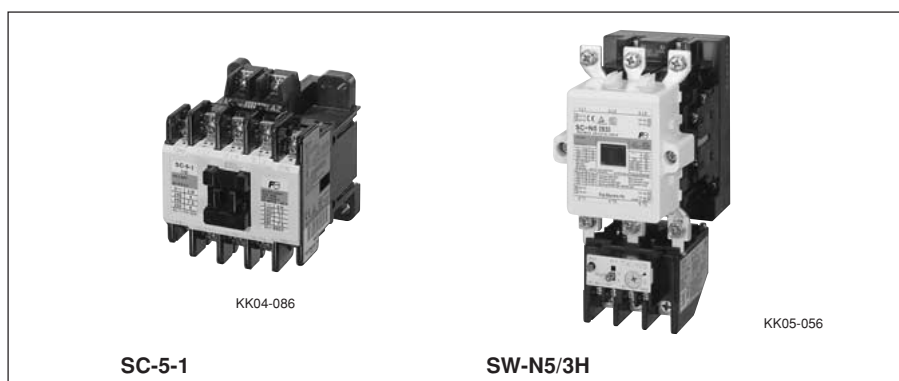

**SC-N1 to SC-N16**

- Adoption of improved contact material and arc-extinguishing grid permits further improvement in breaking efficiency.
- Type and rating are indicated on the front of contactor.
- Auxiliary contact arrangements are available up to 4NO+4NC.
- Can be mounted on 35mm rails to meet the requirements of IEC Standards. (SC-N1 to N3)
- Bifurcated type auxiliary contacts have a high degree of contact reliability. They can be used in low level circuit of 5V, 3mA.(SC-N1 to N12)

**SUPER MAGNET(SC-N5 to SC-N16)**

- The electronically-controlled SUPER MAGNET has an IC built into the coil circuit. Its operation is based on the "AC input, DC operated" concept.
- Operate on both AC and DC power supply. The operating voltage range has been greatly expanded.

- Coil burning and contact chattering due to voltage fluctuation have been eliminated.
- A built-in surge suppression device prevents surges from occurring on ON-OFF operations.

- Thermal overload relays
- Superior protection  
The starter is fitted with a TR type thermal overload relay which features ambient temperature compensation, auto-manual resetting, and trip indicator.
- Alarm contacts are available in 1NO+1NC arrangements.
- Optional operation indicating lamp can be fitted on request.

**Thermal overload relays :**

[See page 01/97.](#)

**Auxiliary contact ratings :**

[See page 01/28.](#)

**Performance data :**

[See page 01/30.](#)

**Coil ratings :** [See page 01/30.](#)

# Magnetic Contactors and Starters

## SC and SW series

### Standard type

#### ■ Dimensions, mm Contactors/Open type

##### SC-03, SC-0

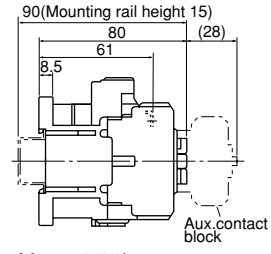

Mass: 0.32kg

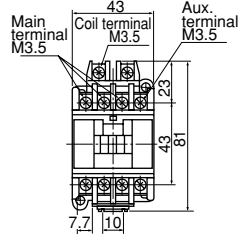

#### Panel drilling

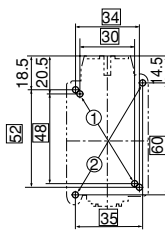

#### ■ Wiring diagrams

##### Auxiliary contact

1NO

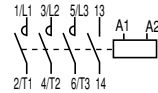

1NC

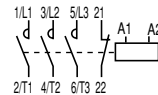

##### SC-05

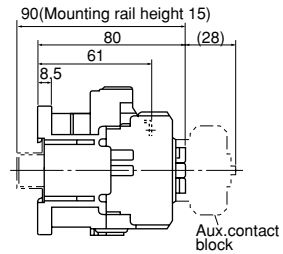

Mass: 0.34kg

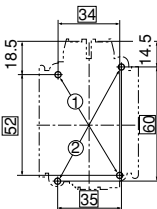
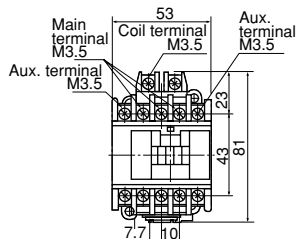

2NO



1NO+1NC



2NC

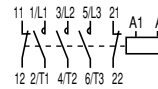

##### SC-4-0, SC-4-1

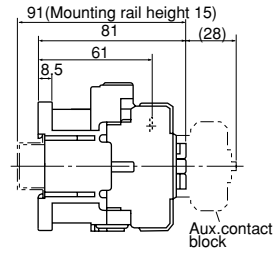

Mass: 0.36kg

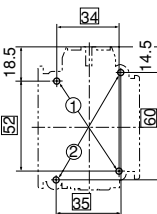
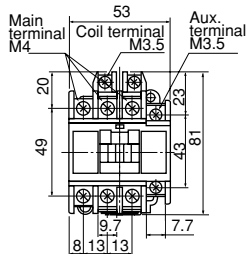

1NO

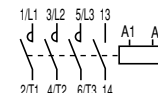

1NC

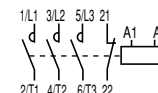

##### SC-5-1

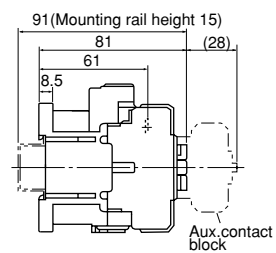

Mass: 0.38kg

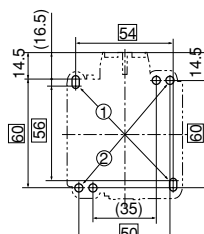
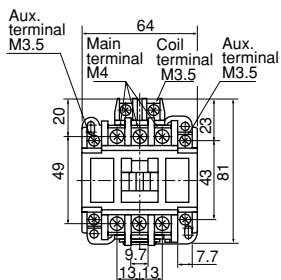

2NO

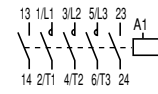

1NO+1NC

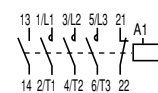

2NC

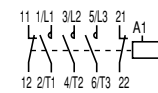

##### SC-5-1

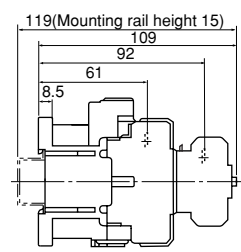

Mass: 0.4kg

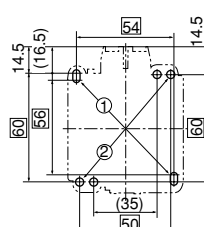
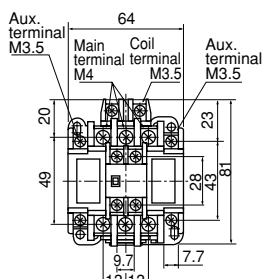

2NO+2NC

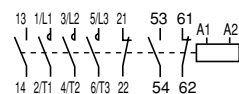

Note: Use the two mounting holes on a diagonal line to mount a contactor.  
Mounting holes indicated by ① are compatible with those of SRC type.  
Mounting holes indicated by ② are compatible with IEC standard

■ Dimensions, mm  
 Contactors/Open type

SC-N1, SC-N2

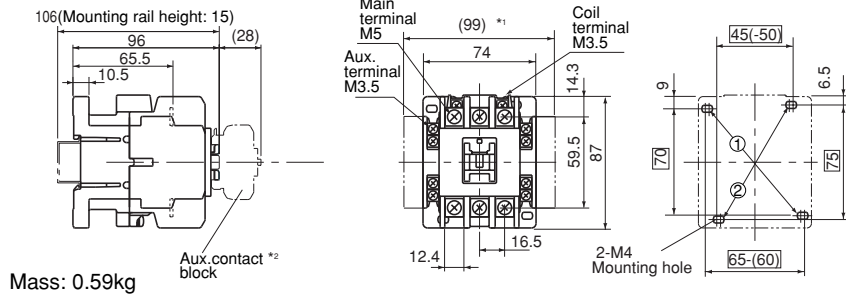

Mass: 0.59kg

■ Wiring diagrams  
 SC-N1 to SC-N16

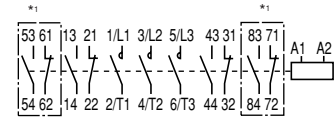

\*1 In case of auxiliary contact 4NO+4NC

SC-N2S, SC-N3

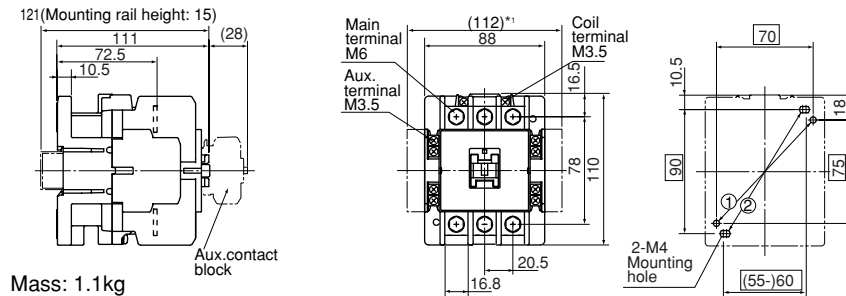

Mass: 1.1kg

SC-N4

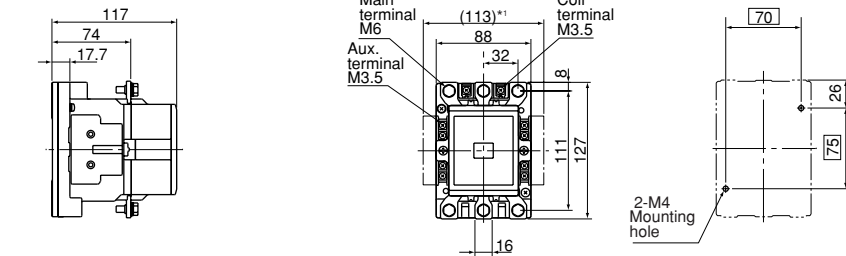

Mass: 1.5kg

SC-N5

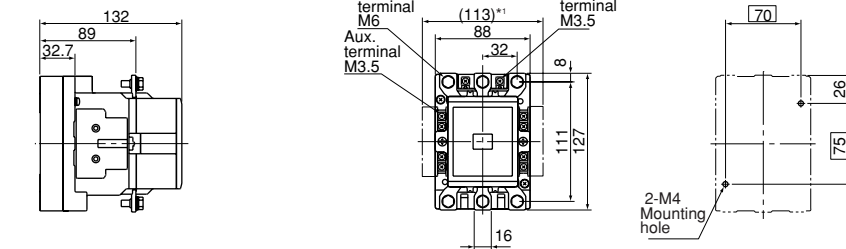

Mass: 1.8kg

SC-N6

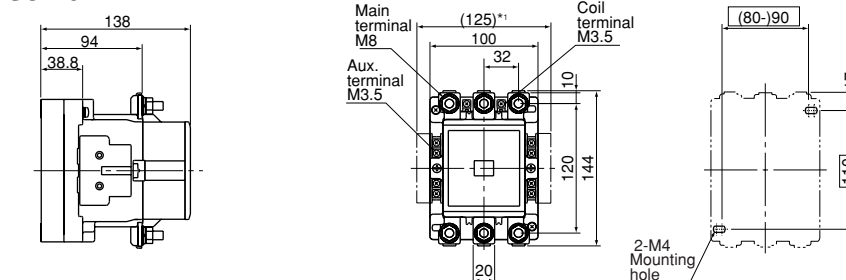

Mass: 2.4kg

Note: • Use the two mounting holes on a diagonal line to mount a contactor.  
 Mounting holes indicated by ① are compatible with those of SRC type.  
 Mounting holes indicated by ② are compatible with IEC standard

\*1 For two side mounting aux. contact blocks mounted  
 \*2 For front mounting aux. contact blocks mounted

# Magnetic Contactors and Starters

## SC and SW series

### Standard type

#### ■ Dimensions, mm Contactors/Open type

##### SC-N7

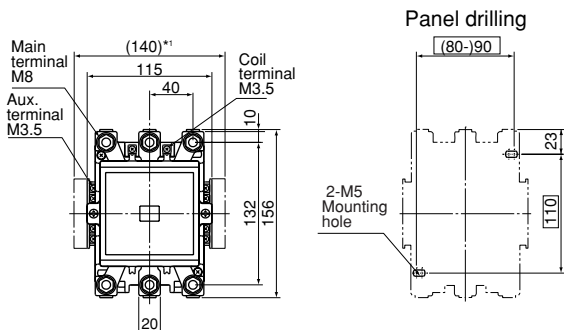
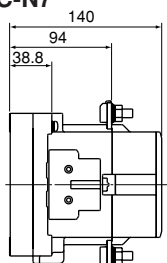

Mass: 2.7kg

##### SC-N8, SC-N10

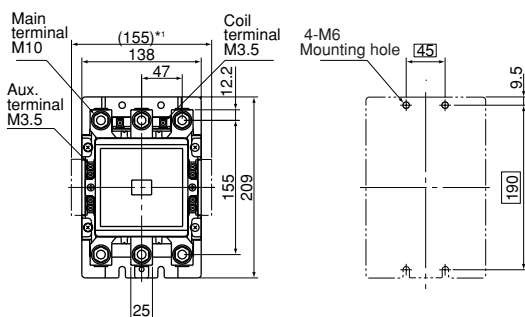
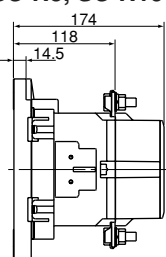

Mass: 4.9kg

##### SC-N11, SC-N12

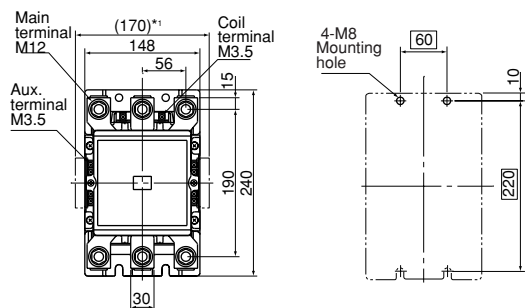
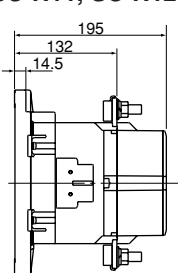

Mass: 7.8kg

##### SC-N14

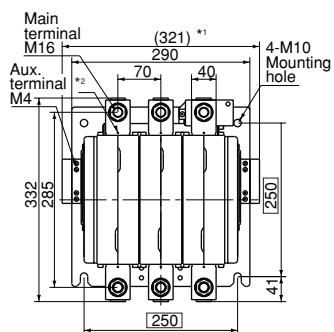
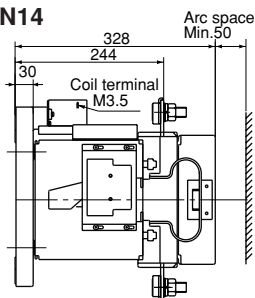

Mass: 32kg

##### SC-N16

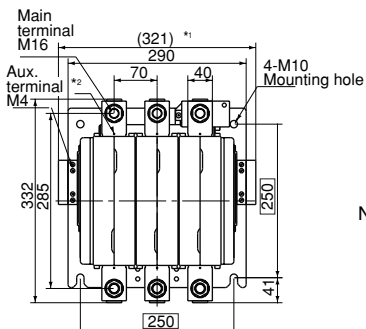
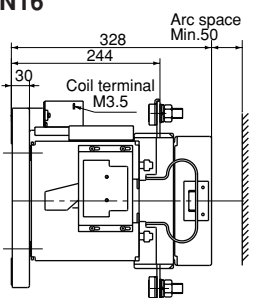

Mass: 34kg

Note: \*1 For two side mounting aux.contact blocks mounted  
\*2 M4 tap for control circuit



■ Dimensions, mm  
**Starters/Open type**  
**SW-03/3H, SW-0/3H**

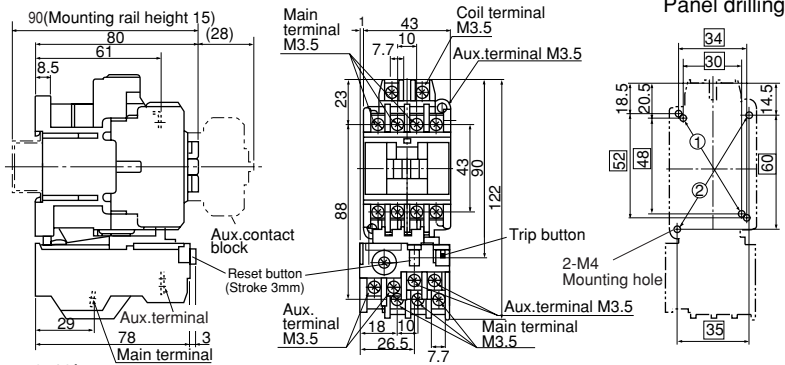

Mass: 0.43kg

**SW-05/3H**

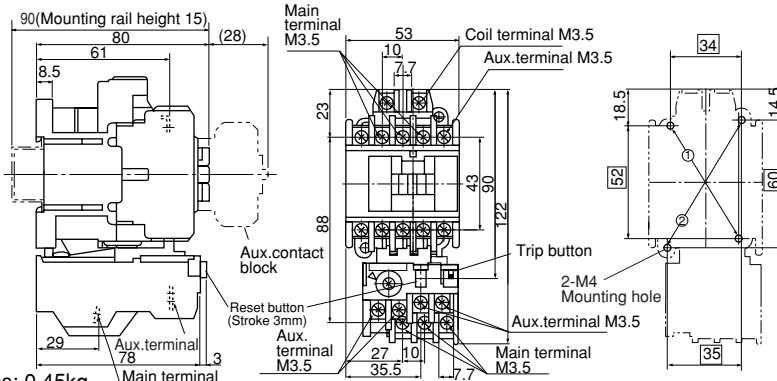

Mass: 0.45kg

**SW-4-0/3H, SW-4-1/3H**

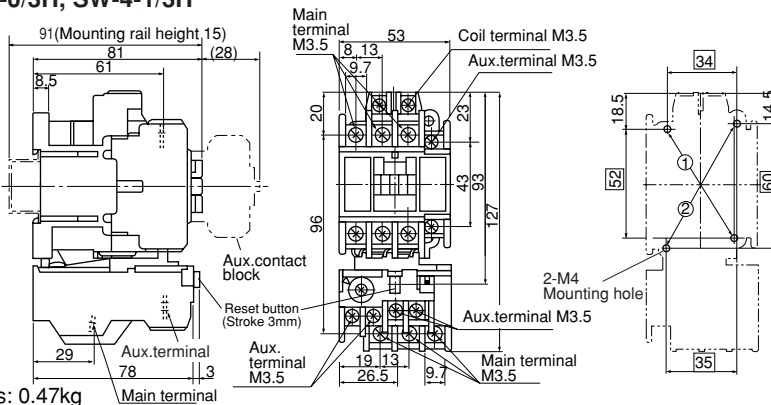

Mass: 0.47kg

**SW-5-1/3H**

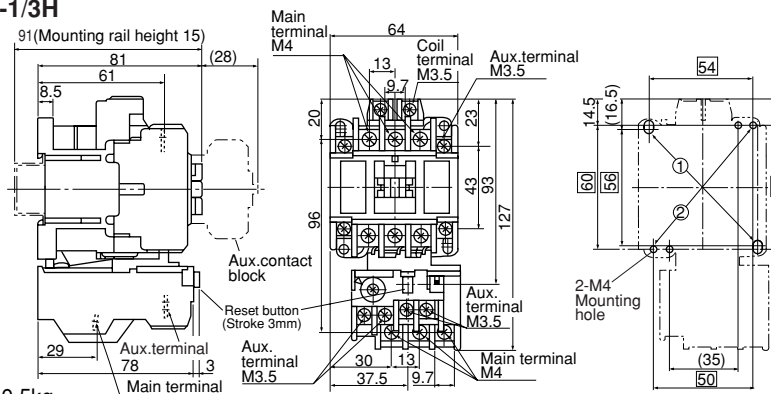

Mass: 0.5kg

■ Wiring diagrams

Auxiliary contact

1NO

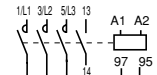

1NC

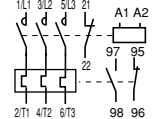

2NO

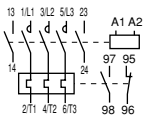

1NO+1NC

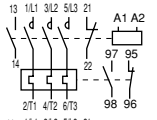

2NC

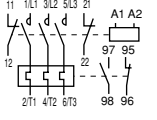

1NO

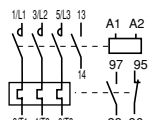

1NC

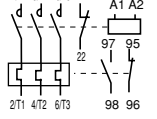

2NO

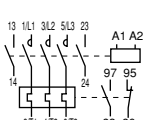

1NO+1NC

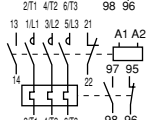

2NC

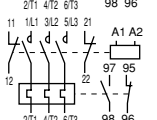

Note: Use the two mounting holes on a diagonal line to mount a contactor.  
 Mounting holes indicated by ① are compatible with those of SRC type.  
 Mounting holes indicated by ② are compatible with IEC standard

# Magnetic Contactors and Starters

## SC and SW series

### Standard type

#### ■ Dimensions, mm Starters/Open type

##### SW-5-1/3H

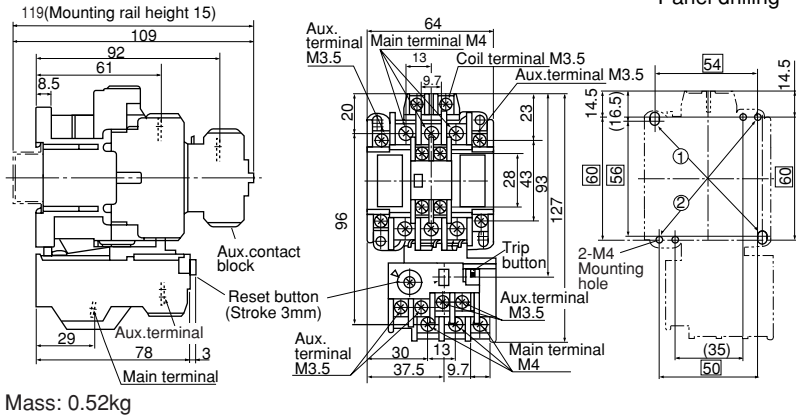

#### ■ Wiring diagrams SW-5-1/3H

Auxiliary contact  
2NC+2NO

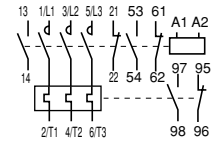

##### SW-N1/3H, SW-N2/3H

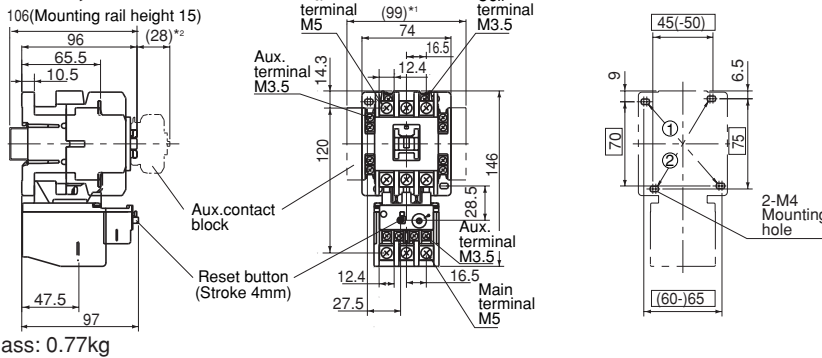

#### ■ Wiring diagrams SW-N1/3H to SW-N8/3H

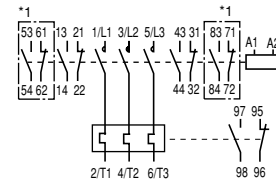

\*1 In case of auxiliary contact 4NO+4NC

##### SW-N2S/3H, SW-N3/3H

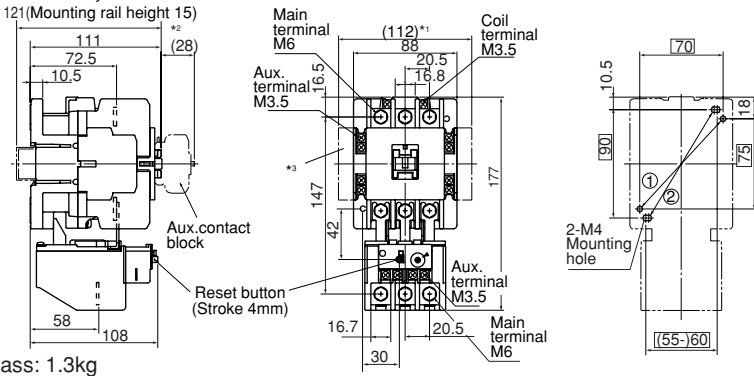

##### SW-N4/3H

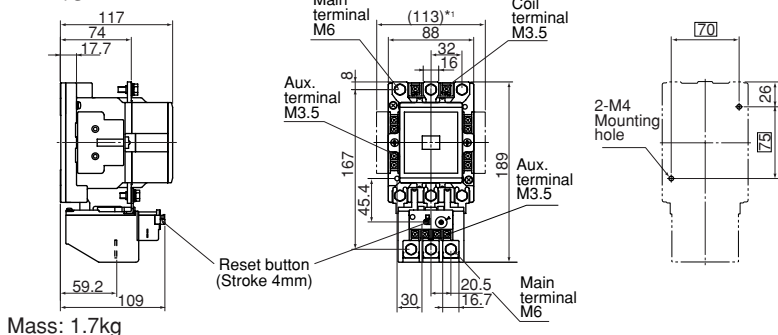

Note: • Use the two mounting holes on a diagonal line to mount a contactor.  
Mounting holes indicated by ① are compatible with those of SRC type.  
Mounting holes indicated by ② are compatible with IEC standard

\*1 For two side mounting aux. contact blocks mounted

\*2 For front mounting aux. contact blocks mounted

■ Dimensions, mm  
**Starters/Open type**  
**SW-N5/3H**

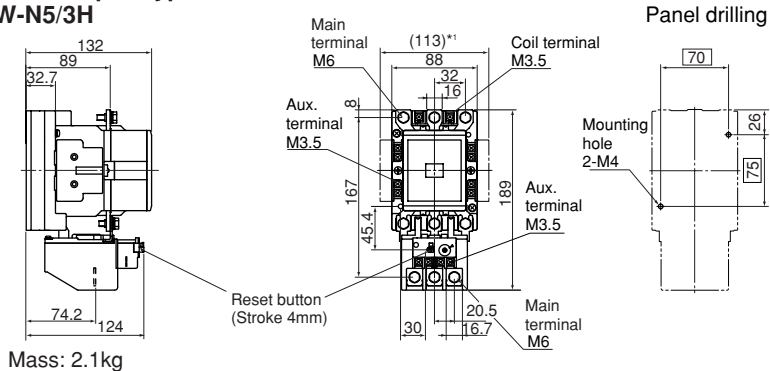

**SW-N6/3H**

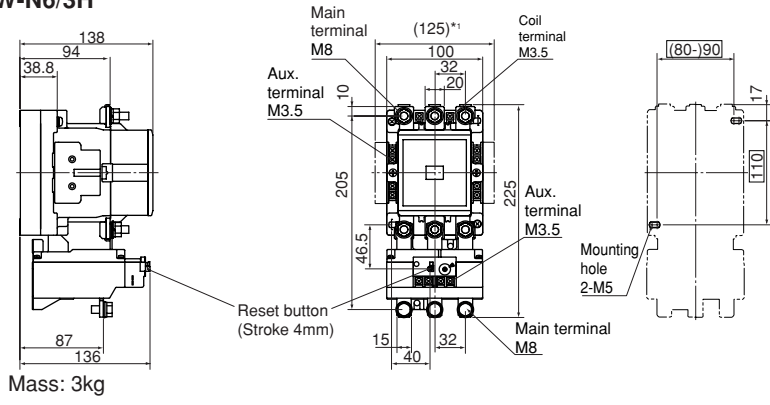

**SW-N7/3H**

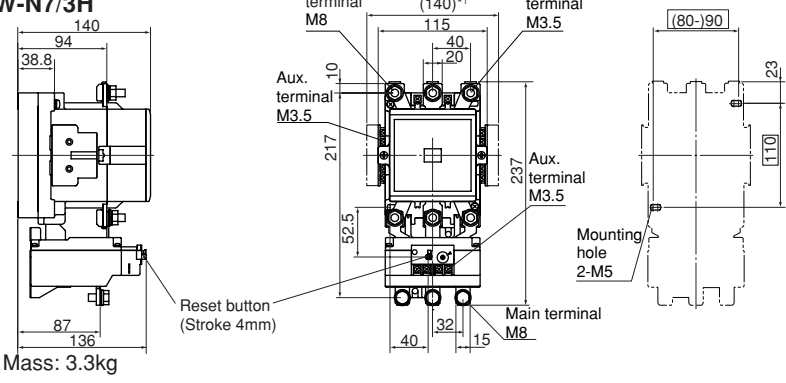

**SW-N8/3H**

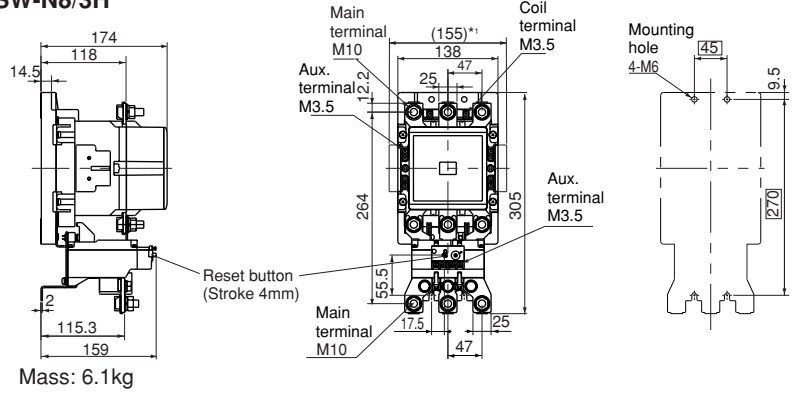

Note: \*1 For two side mounting aux. contact blocks mounted

# Magnetic Contactors and Starters

## SC and SW series

### Standard type

#### ■ Dimensions, mm Starters/Open type SW-N10/3H

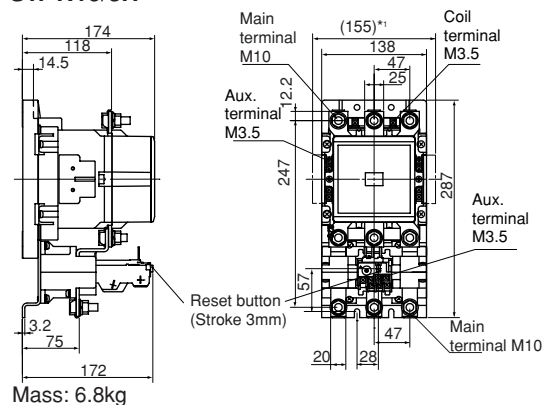

#### Panel drilling

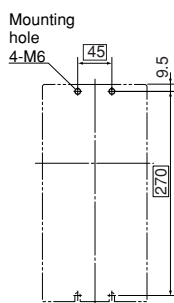

#### ■ Wiring diagrams SW-N10/3H to SW-N14/3H

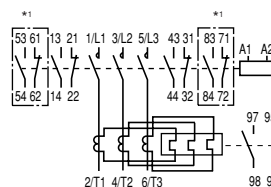

$^{*1}$  In case of auxiliary contact 4NO+4NC

#### SW-N11/3H, SW-N12/3H

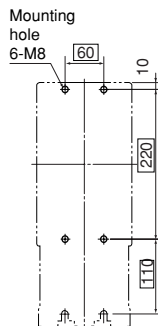
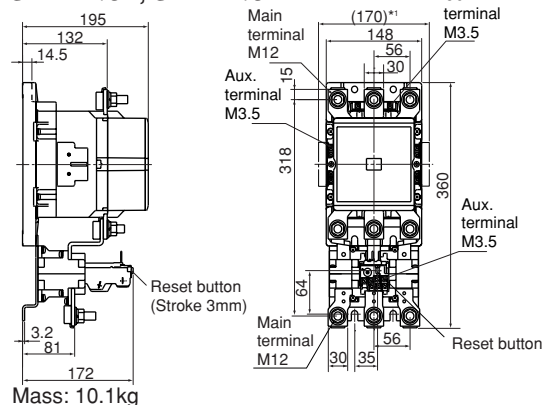

#### SW-N14/3H

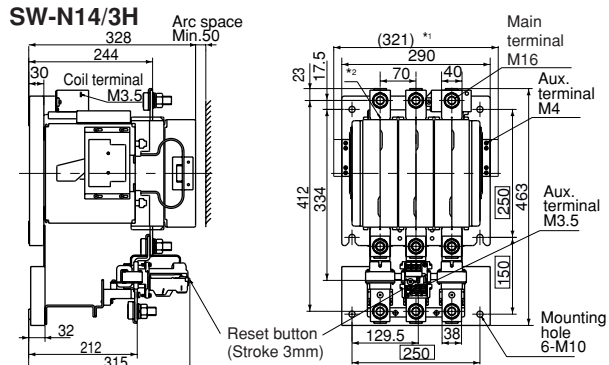

Note:  $^{*1}$  For two side mounting aux. contact blocks mounted

$^{*2}$  For front mounting aux. contact blocks mounted

Starters/Enclosed type



AF88-1347

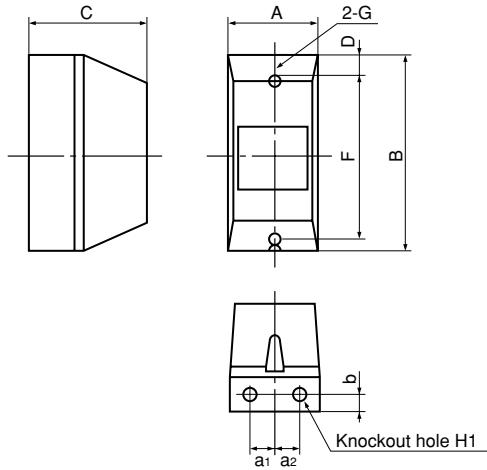

Fig. 1 Plastic enclosure

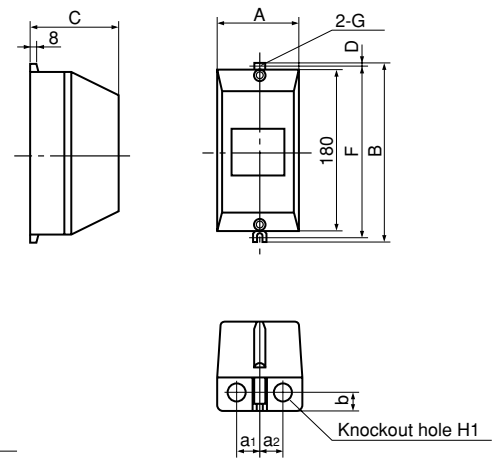

Fig. 2 Plastic enclosure

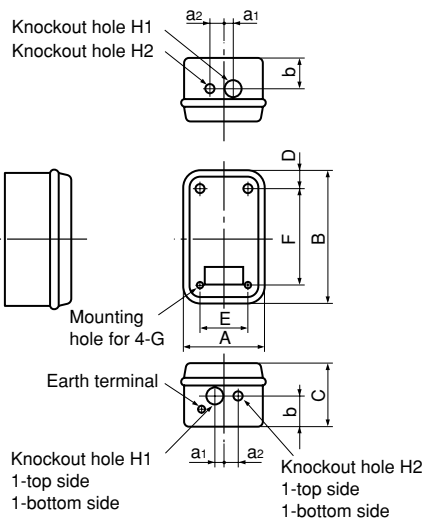

Fig. 3 Steel enclosure

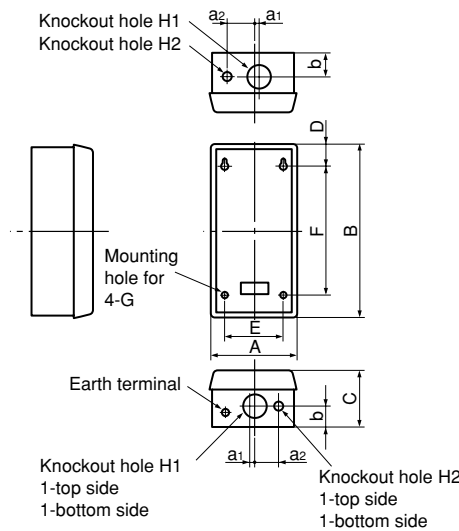

Fig. 4 Steel enclosure

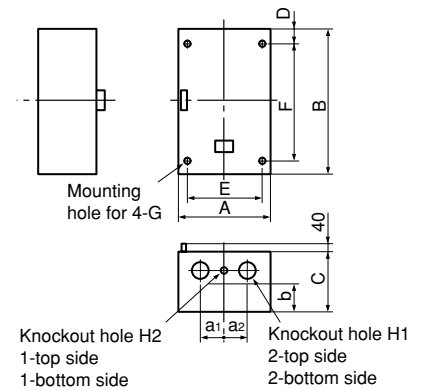

Fig. 5 Steel enclosure

Type	A	B	C	D	E	F	G	Lead hole H1	Lead hole H2	Lead hole a1	Lead hole a2	b	Mass (kg)	Fig. No.
SW-03C/3H	76	165	94	14.5	-	135	M4	φ17	φ17	19	19	18.5	0.7	1
SW-0C/3H	76	165	94	14.5	-	135	M4	φ17	φ17	19	19	18.5	0.7	
SW-05C/3H	76	165	94	14.5	-	135	M4	φ17	φ17	19	19	18.5	0.72	
SW-4-0C/3H	90	200	94	5	-	190	M4	φ21	φ21	24	24	22.5	0.80	2
SW-4-1C/3H	90	200	94	5	-	190	M4	φ21	φ21	24	24	22.5	0.80	
SW-5-1C/3H	90	200	94	5	-	190	M4	φ21	φ21	24	24	22.5	0.83	
SW-N1C/3H	145	246	132	18	80	210	M6	φ28	φ28	Top: 20	60	2.0	3	
SW-N2C/3H	145	246	132	18	80	210	M6	φ28	φ28	Bottom: 27	60	2.0		
SW-N2SC/3H	175	320	145	35	110	250	M6	φ35	φ28	15	35	70		3
SW-N3C/3H	175	320	145	35	110	250	M6	φ35	φ28	15	35	70		3
SW-N4C/3H	200	400	160	37	125	325	M8	φ43	φ28	20	40	80		4.4
SW-N5C/3H	200	400	160	37	125	325	M8	φ43	φ28	20	40	80		7.0
SW-N6C/3H	225	450	180	50	150	350	M8	φ52	φ28	10	70	80	8.4	4
SW-N7C/3H	280	560	210	55	175	450	M10	φ65	φ28	10	80	95	12.3	
SW-N8C/3H	335	670	225	85	200	500	M10	φ78	φ28	0	100	95	18.1	
SW-N10C/3H	335	670	225	85	200	500	M10	φ78	φ28	0	100	95	18.8	
SW-N11C/3H	400	800	250	100	250	600	M10	φ105	φ28	0	150	100	24.6	
SW-N12C/3H	400	800	250	100	250	600	M10	φ105	φ28	0	150	100	25.1	
SW-N14C/3H	600	950	400	75	500	800	M12	φ105	φ28	150	150	280	97.0	5

Note: Dimensions of enclosed type contactor SC-03C to SC-N14C are same as those of starters. Contact FUJI for mass.

# Magnetic Contactors and Starters

## SC and SW series

### Reversing standard type

#### Reversing standard type contactors and starters

##### ■ Description

The reversing starter consists of two magnetic contactors and a thermal overload relay. They are suitable for across-the-line starting and reversing of 3-phase squirrel-cage rotor and slip-ring motors.

This starter is provided with a built-in "perfect interlock safety mechanism" which prevents the engagement of forward-reverse contactors simultaneously, as well as electrical interlock.

Where there is a danger of forward-reverse being engaged at the same time, i.e., in the case of power source switching, hoist or machine tool controls, etc. then this type is recommended. The action is simple and positive, and free from trouble in operation.

##### ■ Operating mechanism

When one contactor begins to move the other contactor is locked in position. An arm is used to actuate each contactor so that there is no possibility of double engagement.



##### ■ Ratings of auxiliary contact and coil:

See pages 01/28 and 01/30.

##### ■ Performance data:

Same as standard open type. See page 01/30.

##### Mechanism principle (Explanation only)

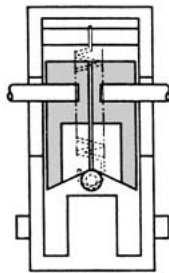

Both contactors open position

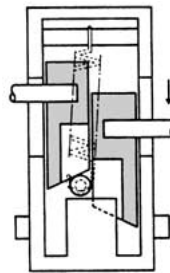

Forward contactor closed position

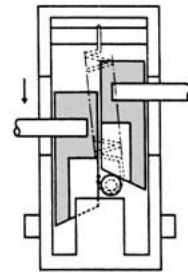

Reverse contactor closed position

##### ■ Ordering information

Specify the following:

1. Ordering code
2. Overload relay setting range code
3. Operating coil voltage code
4. Auxiliary contact arrangement as shown in the table below.

Example: (2NO + 2NC) × 2

##### ■ Types and ratings

Max. motor capacity (kw)	Rated operation current (A)		Auxiliary contact	Contactor		Starter (3-element)				
	200V	380V		Open Type	Ordering code	Open Type	Ordering code	Enclosed Type	Ordering code	
200V 240V	380V 440V	200V 240V	380V 440V							
2.5	4	11	9	1NC×2*1	SC-03RM	SC11RA-■01	SW-03RM/3H	SC11RAN-■01T□□	SW-03RMC/3H	SC11MAN-■01T□□
3.5	5.5	13	12	1NC×2*1	SC-0RM	SC13RA-■01	SW-0RM/3H	SC13RAN-■01T□□	SW-0RMC/3H	SC13MAN-■01T□□
3.5	5.5	13	12	(1NO+1NC)×2*2	SC-05RM	SC14RA-■11	SW-05RM/3H	SC14RAN-■11T□□	SW-05RMC/3H	SC14MAN-■11T□□
4.5	7.5	18	16	1NC×2*1	SC-4-0RM	SC18RA-■01	SW-4-0RM/3H	SC18RAN-■01T□□	SW-4-0RMC/3H	SC18MAN-■01T□□
5.5	11	22	22	1NC×2*1	SC-4-1RM	SC19RA-■01	SW-4-1RM/3H	SC19RAN-■01T□□	SW-4-1RMC/3H	SC19MAN-■01T□□
5.5	11	22	22	(1NO+1NC)×2*3	SC-5-1RM	SC20RA-■11	SW-5-1RM/3H	SC20RAN-■11T□□	SW-5-1RMC/3H	SC20MAN-■11T□□
7.5	15	32	32	(2NO+2NC)×2*3	SC-N1RM	SC25BRA-■22	SW-N1RM/3H	SC25BRAN-■22T□□	SW-N1RMC/3H	SC25BMAN-■22T□□
11	18.5	40	40	(2NO+2NC)×2*3	SC-N2RM	SC35BRA-■22	SW-N2RM/3H	SC35BRAN-■22T□□	SW-N2RMC/3H	SC35BMAN-■22T□□
15	22	50	50	(2NO+2NC)×2*3	SC-N2SRM	SC50BRA-■22	SW-N2SRM/3H	SC50BRAN-■22T□□	SW-N2SRMC/3H	SC50BMAN-■22T□□
18.5	30	65	65	(2NO+2NC)×2*3	SC-N3RM	SC65BRA-■22	SW-N3RM/3H	SC65BRAN-■22T□□	SW-N3RMC/3H	SC65BMAN-■22T□□
22	40	80	80	(2NO+2NC)×2*3	SC-N4RM	SC80BRA-■22	SW-N4RM/3H	SC80BRAN-■22T□□	SW-N4RMC/3H	SC80BMAN-■22T□□
30	55	105	105	(2NO+2NC)×2*3	SC-N5RM	SC93BRA-■22	SW-N5RM/3H	SC93BRAN-■22T□□	SW-N5RMC/3H	SC93BMAN-■22T□□
37	60	125	125	(2NO+2NC)×2*3	SC-N6RM	SC1CBRA-■22	SW-N6RM/3H	SC1CBRAN-■22T□□	SW-N6RMC/3H	SC1CBMAN-■22T□□
45	75	150	150	(2NO+2NC)×2*3	SC-N7RM	SC1FBRA-■22	SW-N7RM/3H	SC1FBRAN-■22T□□	SW-N7RMC/3H	SC1FBMAN-■22T□□
55	90	180	180	(2NO+2NC)×2*3	SC-N8RM	SC1JBRA-■22	SW-N8RM/3H	SC1JBRAN-■22T□□	SW-N8RMC/3H	SC1JBMAN-■22T□□
65	110	220	220	(2NO+2NC)×2*3	SC-N10RM	SC2CBRA-■22	SW-N10RM/3H	SC2CBRAN-■22T□□	SW-N10RMC/3H	SC2CBMAN-■22T□□
90	160	300	300	(2NO+2NC)×2*3	SC-N11RM	SC3ABRA-■22	SW-N11RM/3H	SC3ABRAN-■22T□□		
120	220	400	400	(2NO+2NC)×2*3	SC-N12RM	SC4ABRA-■22	SW-N12RM/3H	SC4ABRAN-■22T□□		
180	315	600	600	(2NO+2NC)×2*3	SC-N14RM	SC6ABRA-■22	SW-N14RM/3H	SC6ABRAN-■22T□□		

Notes: 1. ■ : Coil voltage code. □ : Thermal overload relay ampere setting range code. See page 01/27.  
2. \*1: Auxiliary contact 1NO×2 is available on request. However, these contactors are not electrically interlocked. Be sure to arrange electrical interlock circuit externally to avoid short-circuit accidents.

\*2: Auxiliary contact 2NC×2 is available on request.  
\*3: Auxiliary contact (3NO+3NC)×2 is available on request for frame size N1 and above. Auxiliary contact (4NO+4NC)×2 is available on request for frame size N1 to N3.  
3. Contactor with enclosure is available on request.

■ Dimensions, mm  
 Reversing contactors/Open type

■ Wiring diagrams

**SC-03RM, SC-0RM**

Panel drilling

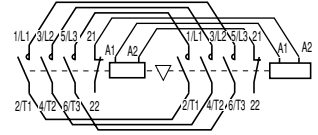
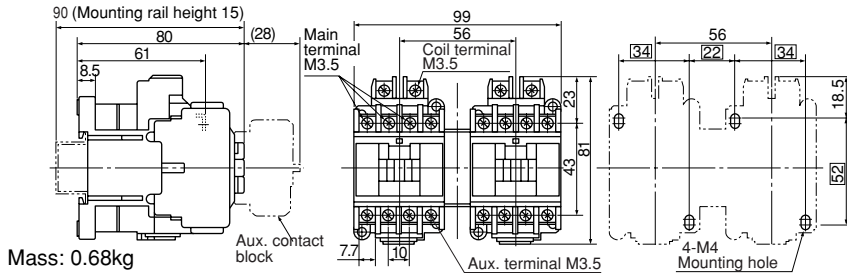

Mass: 0.68kg

**SC-05RM**

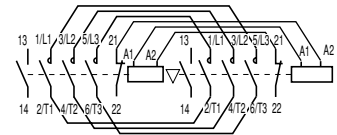
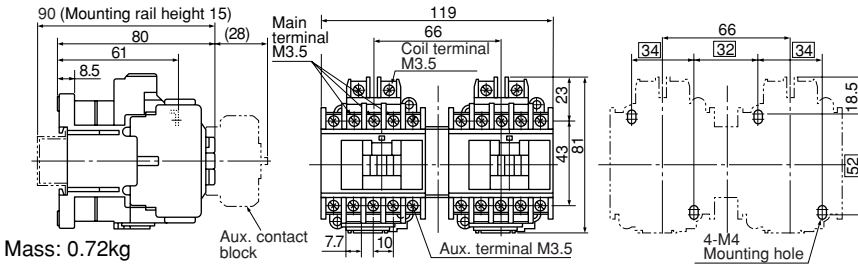

Mass: 0.72kg

**SC-4-0RM, SC-4-1RM**

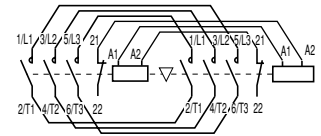
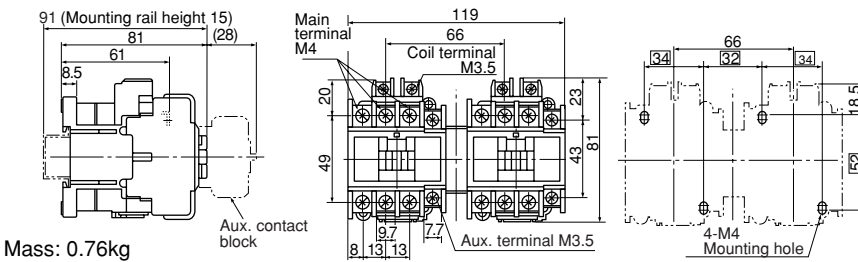

Mass: 0.76kg

**SC-5-1RM**

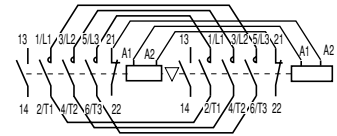
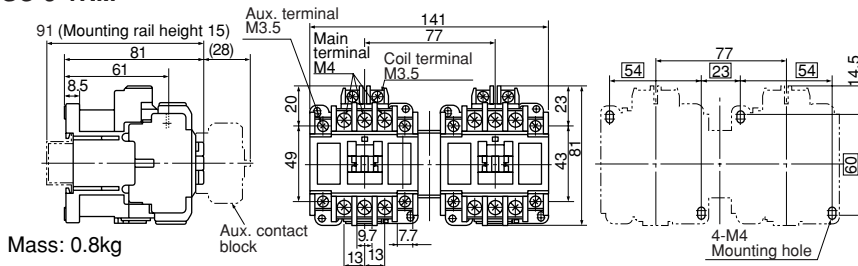

Mass: 0.8kg

**SC-N1RM, SC-N2RM**

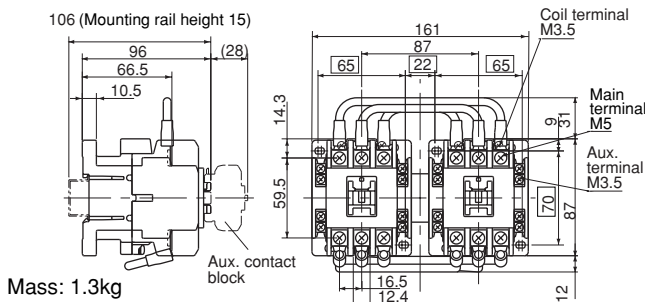

■ Wiring diagrams

**SC-N1RM to SC-N3RM**

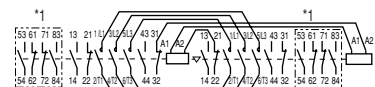

\*1 In case of auxiliary contact 4NO+4NC

**SC-N4RM to SC-N14RM**

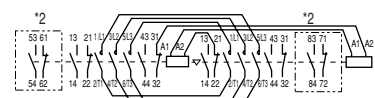

\*2 In case of auxiliary contact 3NO+3NC

Mass: 1.3kg

# Magnetic Contactors and Starters

## SC and SW series

### Reversing standard type

#### ■ Dimensions, mm Reversing contactors/Open type

##### SC-N2SRM, SC-N3RM

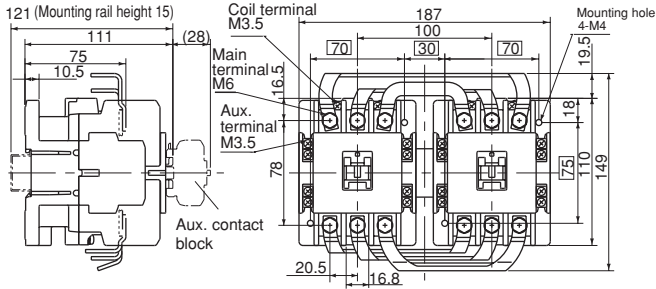

Mass: 2.3kg

##### SC-N4RM

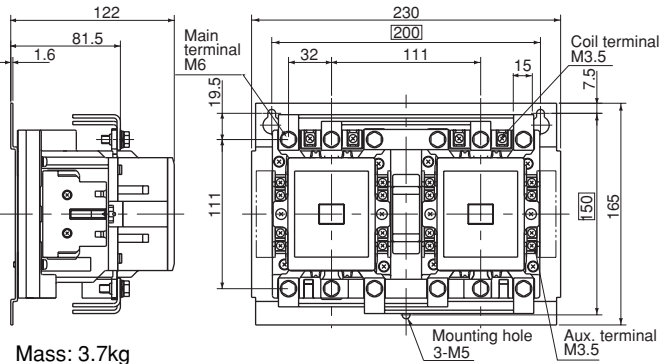

Mass: 3.7kg

##### SC-N5RM

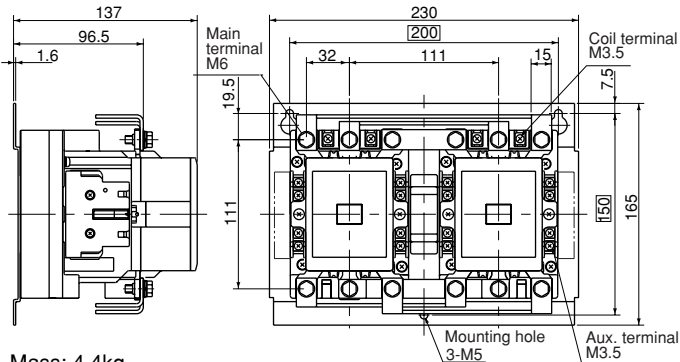

Mass: 4.4kg

##### SC-N6RM

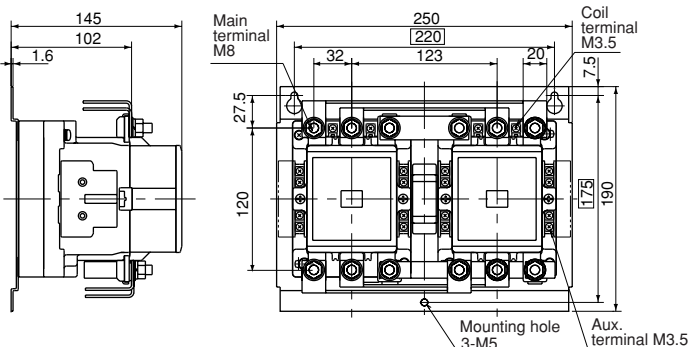

Mass: 5.9kg

##### SC-N7RM

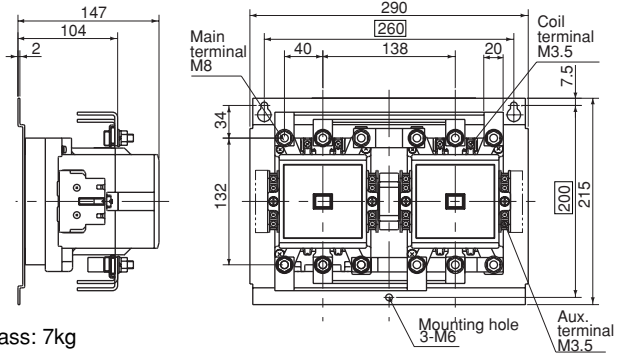

Mass: 7kg

##### SC-N8RM, SC-N10RM

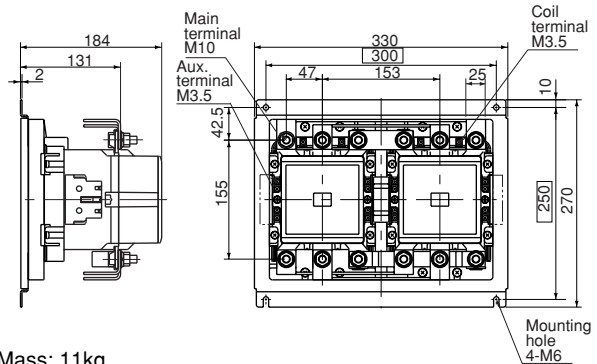

Mass: 11kg

##### SC-N11RM, SC-N12RM

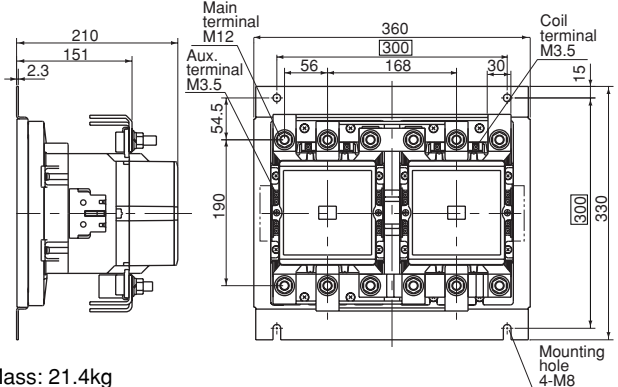

Mass: 21.4kg

##### SC-N14RM

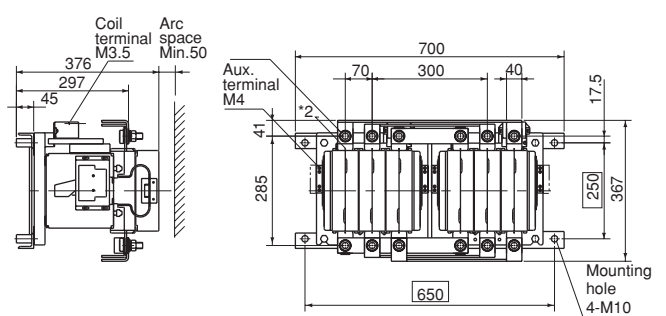

Mass: 80kg

\*2 M4 tap for control circuit



■ Dimensions, mm  
 Reversing motor starters/Open type

**SW-03RM/3H, SW-0RM/3H**

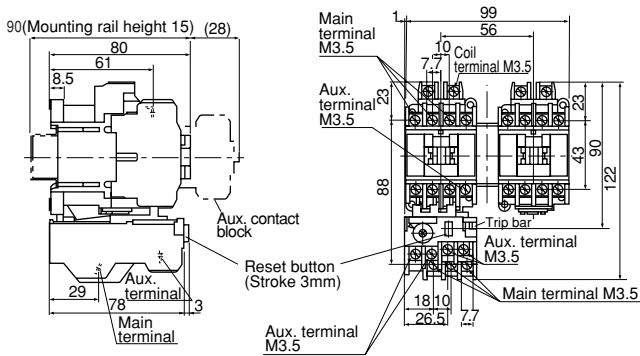

Mass: 0.79kg

**SW-05RM/3H**

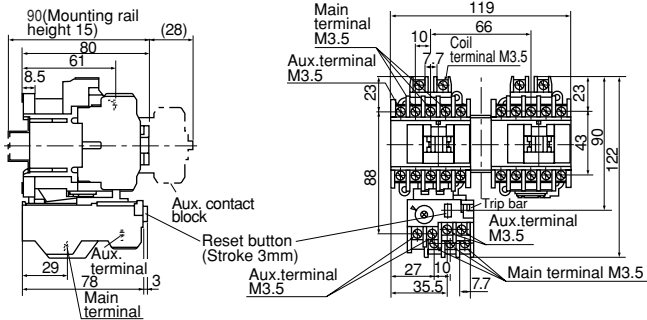

Mass: 0.83kg

**SW-4-0RM/3H, SW-4-1RM/3H**

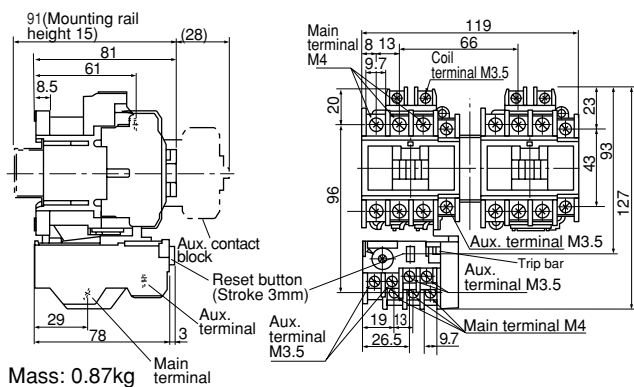

Mass: 0.87kg

**SW-5-1RM/3H**

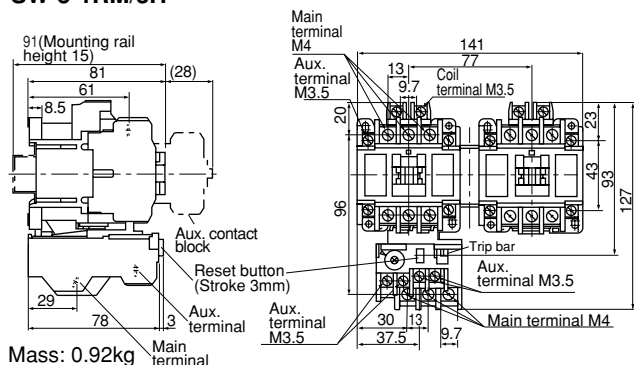

Mass: 0.92kg

■ Wiring diagrams

Panel drilling

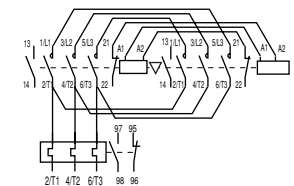
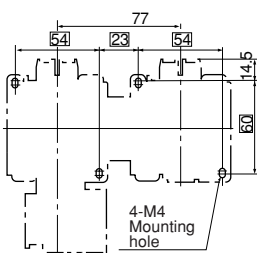
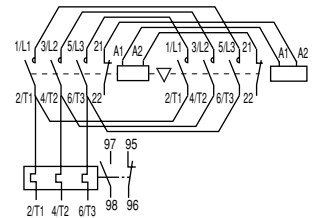
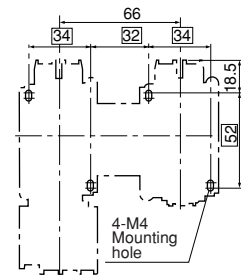
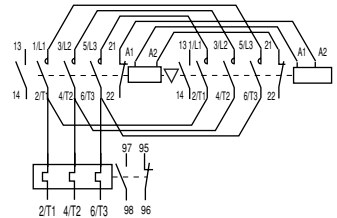
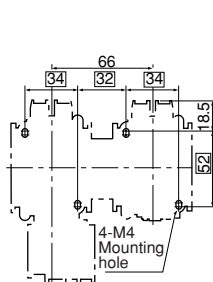
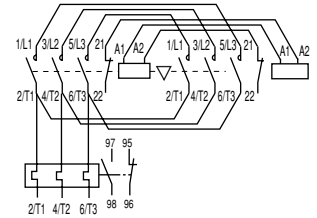
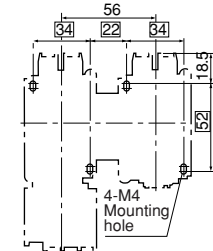

# Magnetic Contactors and Starters

## SC and SW series

### Reversing standard type

#### ■ Dimensions, mm

#### Reversing motor starters/Open type

#### SW-N1RM/3H, SW-N2RM/3H

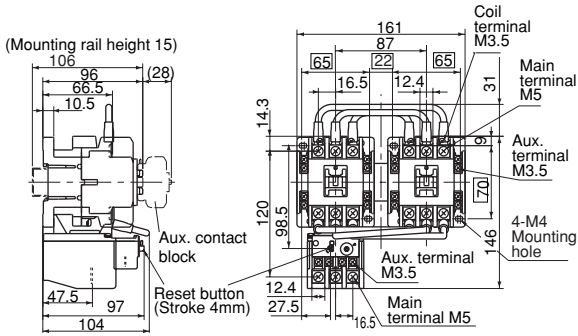

Mass: 1.5kg

#### SW-N6RM/3H

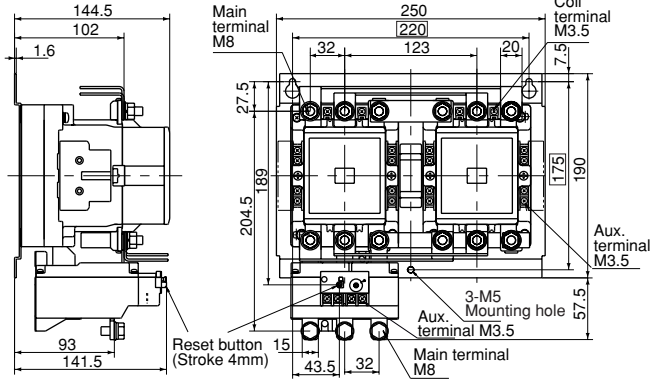

Mass: 6.5kg

#### SW-N2SRM/3H, SW-N3RM/3H

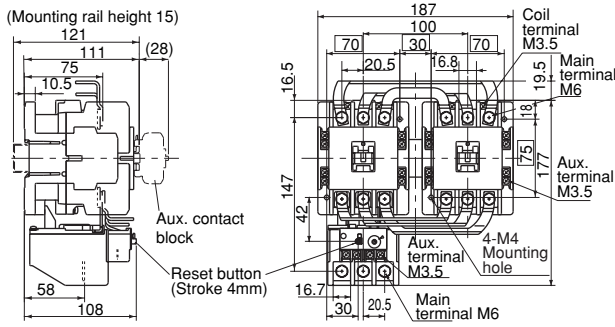

Mass: 2.6kg

#### SW-N7RM/3H

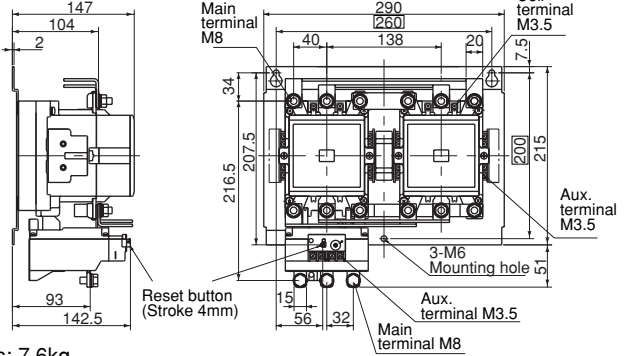

Mass: 7.6kg

#### SW-N4RM/3H

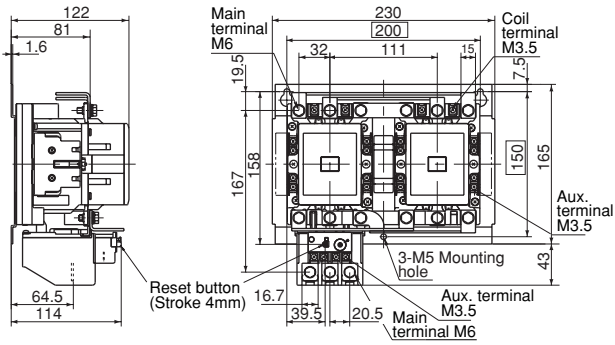

Mass: 4kg

#### SW-N8RM/3H

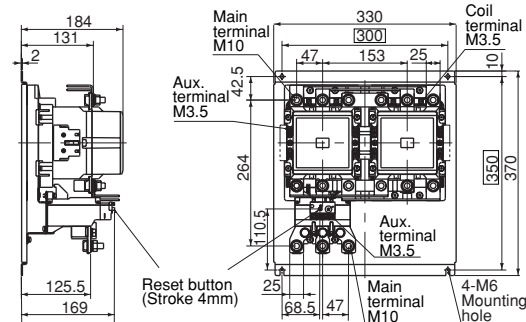

Mass: 12.2kg

#### SW-N5RM/3H

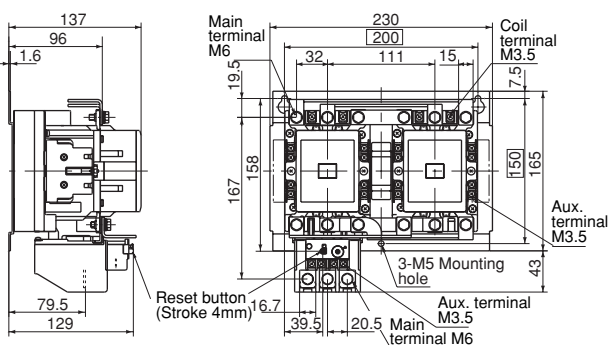

Mass: 4.7kg

#### SW-N10RM/3H

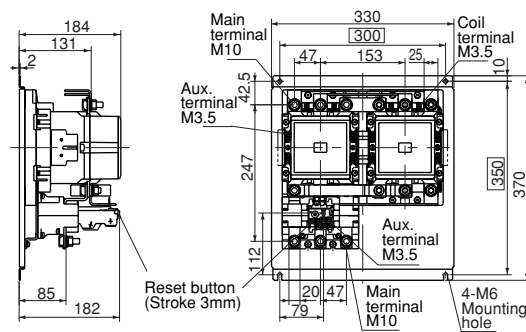

Mass: 12.9kg

■ Dimensions, mm  
 Reversing motor starters/Open type

SW-N11RM/3H, SW-N12RM/3H

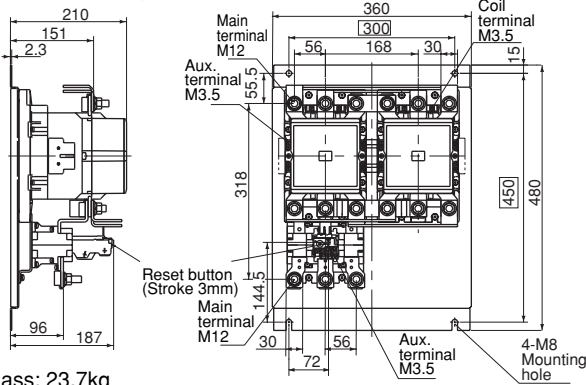

Mass: 23.7kg

SW-N14RM/3H

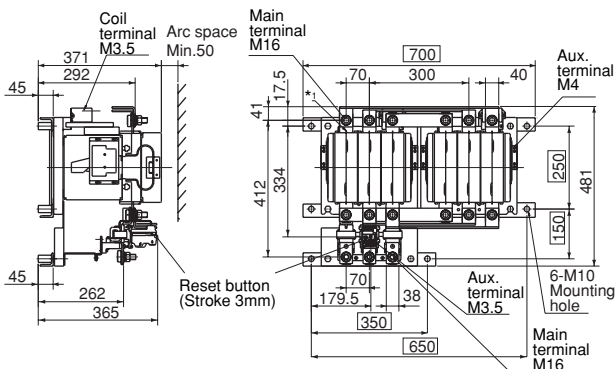

Mass: 85kg

\*1 M4 tap for control circuit

■ Wiring diagrams  
 SW-N1RM/3H to SW-N8RM/3H

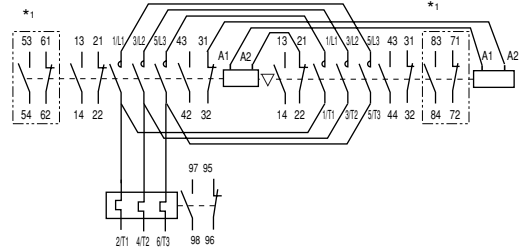

\*1 In case of auxiliary contact 3NO+3NC

SW-N10RM/3H to SW-N12RM/3H

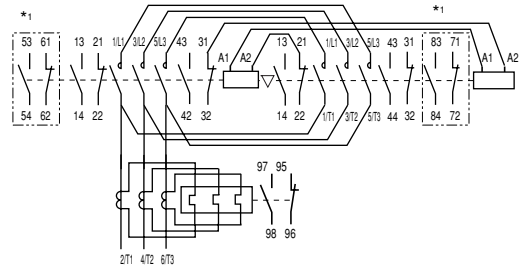

\*1 In case of auxiliary contact 3NO+3NC

SW-N14RM/3H

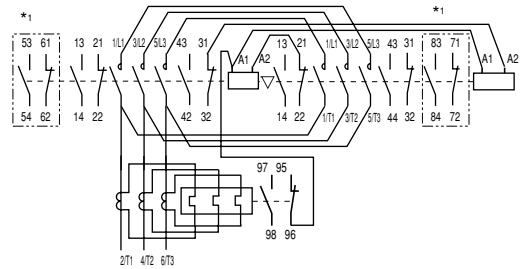

\*1 In case of auxiliary contact 3NO+3NC

# Magnetic Contactors and Starters

## SC and SW series

### Reversing standard type

#### ■ Dimensions, mm

#### Reversing motor starters/Enclosed type

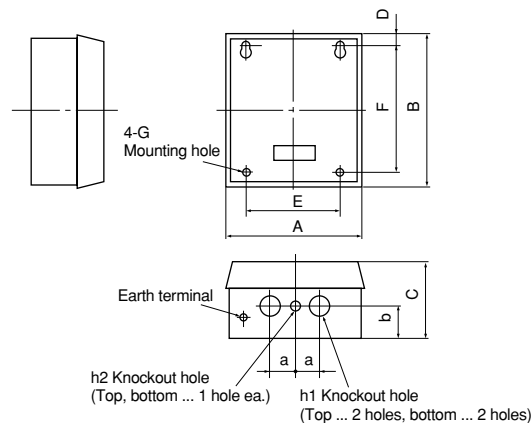

Type	A	B	C	D	E	F	G	h1	h2	a	b	Mass (kg) 3-element
SW-03RMC/3H	192	192	100	16	130	160	4-M6	φ22	—	65	65	1.9
SW-0RMC/3H	192	192	100	16	130	160	4-M6	φ22	—	65	65	1.9
SW-05RMC/3H	192	192	100	16	130	160	4-M6	φ22	—	65	65	1.9
SW-4-0RMC/3H	192	192	100	16	130	160	4-M6	φ22	—	65	65	1.95
SW-4-1RMC/3H	192	192	100	16	130	160	4-M6	φ22	—	65	65	1.95
SW-5-1RMC/3H	192	192	100	16	130	160	4-M6	φ22	—	65	65	2.0
SW-N1RMC/3H	254	250	131	20	185	210	4-M6	φ28	—	80	70	3.8
SW-N2RMC/3H	254	250	131	20	185	210	4-M6	φ28	—	80	70	3.8
SW-N2SRMC/3H	280	320	145	35	200	250	4-M6	φ35	φ28	55	70	6.6
SW-N3RMC/3H	280	320	145	35	200	250	4-M6	φ35	φ28	55	70	6.6
SW-N4RMC/3H	355	400	160	37.5	250	325	4-M8	φ43	φ28	65	80	10.7
SW-N5RMC/3H	355	400	160	37.5	250	325	4-M8	φ43	φ28	65	80	11.4
SW-N6RMC/3H	400	450	180	50	300	350	4-M8	φ52	φ28	85	80	14.3
SW-N7RMC/3H	450	560	210	55	350	450	4-M10	φ65	φ28	90	95	21.5
SW-N8RMC/3H	500	670	225	85	400	500	4-M10	φ78	φ28	90	105	29.4
SW-N10RMC/3H	500	670	225	85	400	500	4-M10	φ78	φ28	90	105	32.4

Notes: • SW-5-1RMC/3H with aux. contact 2×2NO:2NC is not available.  
• Dimensions of enclosed type contactor SC-03RMC to SC-N10RMC/3H are same as those of starters. Contact FUJI for mass.

**DC operated contactors and starters**

Up to 37kW 440 Volts

■ **Description**

In most cases general purpose AC magnetic motor starters employ AC coils, and although “AC motor with AC controls” is the normal practice, in complicated controls troubles can be expected due to the instantaneous voltage drop or power failure in the AC power source. Thus, in some applications “AC motor with DC control” offers a better system.

FUJI manufactures two types of DC operated contactors. In one type the ON/OFF operation is carried out by a DC operating coil. The other type is operated by the SUPER MAGNET. The SC-03/G to N3/G types use the single coil system. They can be operated at full voltage. When requiring the DC operation for SC-N1 to N4 contactor, the contactor with SUPER MAGNET is substituted(SC-N1/SE to N4/SE). AC/DC operated types with SUPER

MAGNET  
 • SC-N1/SE to N4/SE, SW-N1/SE to N4/SE

• SC-N5 to N16, SW-N5/3H to 14/3H  
 These standard types employ the SUPER MAGNET.

■ **Ordering information**

Specify the following:

1. Ordering code
2. Operating coil voltage code
3. Contact arrangement:

In the case of the frame size 0/G to 5-1/G, specify the contact arrangement.

4. Overload relay setting range code.

■ **Ratings**

Max. motor capacity (kW)		Operational current (A)		Thermal current (A)	Auxiliary contact		Contactor Type	Starter (3-element) Type
200V	380V	200V	380V		NO	NC		
240V	440V	240V	440V					
2.5	4	11	9	20	1	—*1	SC-03/G	SW-03/G3H
3.5	5.5	13	12	20	1	—*1	SC-0/G	SW-0/G3H
3.5	5.5	13	12	20	1	1*2	SC-05/G	SW-05/G3H
4.5	7.5	18	16	25	1	—*1	SC-4-0/G	SW-4-0/G3H
5.5	11	22	22	32	1	—*1	SC-4-1/G	SW-4-1/G3H
5.5	11	22	22	32	1	1*3	SC-5-1/G	SW-5-1/G3H
7.5	15	32	32	50	2	2	SC-N1/G	SW-N1/G3H
11	18.5	40	40	60	2	2	SC-N2/G	SW-N2/G3H
15	22	50	50	80	2	2	SC-N2S/G	SW-N2S/G3H
18.5	30	65	65	100	2	2	SC-N3/G	SW-N3/G3H
7.5	15	32	32	50	2	2	SC-N1/SE	SW-N1/SE3H
11	18.5	40	40	60	2	2	SC-N2/SE	SW-N2/SE3H
15	22	50	50	80	2	2	SC-N2S/SE	SW-N2S/SE3H
18.5	30	65	65	100	2	2	SC-N3/SE	SW-N3/SE3H
22	40	80	80	135	2	2	SC-N4/SE	SW-N4/SE3H

Notes: 1. \*1 Auxiliary contact 1NC is available. \*2 Auxiliary contact 2NO or 2NC is available.  
 \*3 Auxiliary contact 2NO, 2NC, or 2NO+2NC is available. For enclosed type, 2NO+2NC is not available  
 2. Auxiliary contact 4NO+4NC is available on request for frame size N1 and above.



■ **Coil ratings**

Type	Coil voltage (V DC)	Power consumption		Operating characteristic	
		Inrush (W)	Sealed (W)	Pick-up voltage (V)	Drop-out voltage (V)
SC-03/G	12, 24, 48, 60,	7	7	88–124	24–52
SC-0/G	100, 110, 120	7	7	88–124	24–52
SC-05/G	200, 210, 220	7	7	86–122	28–56
SC-4-0/G		7	7	92–128	28–56
SC-4-1/G		7	7	92–128	28–56
SC-5-1/G		7	7	92–130	30–60
SC-N1/G		9	9	80–120	30–70
SC-N2/G		9	9	80–120	30–70
SC-N2S/G		12	12	80–120	24–60
SC-N3/G		12	12	80–120	24–60
SC-N1/SE	100–120 *1	150	2.6	140–160	40–100
SC-N2/SE	200–240 *2	150	2.6	140–160	40–100
SC-N2S/SE		185	2.7	140–160	40–100
SC-N3/SE		185	2.7	140–160	40–100
SC-N4/SE	24, 48	110	3.0	140–160	40–100

Notes: Operating coil voltage 200V DC for 03/G to N3/G  
 220V DC for N1/SE to N4/SE

\*1 The coil voltage from a DC power supply with single phase full-wave rectification will be 100 to 110 V.

\*2 The coil voltage from a DC power supply with single phase full-wave rectification will be 200 to 220 V.

■ **UL, CSA, TÜV and CCC approved:**

See page 01/129, 136, 140.

■ **Auxiliary contact**

Same as standard type, See page 01/28.

# Magnetic Contactors and Starters

## SC and SW series

### DC operated

#### ■ Dimensions

#### DC operated contactors

#### SC-03/G, SC-0/G

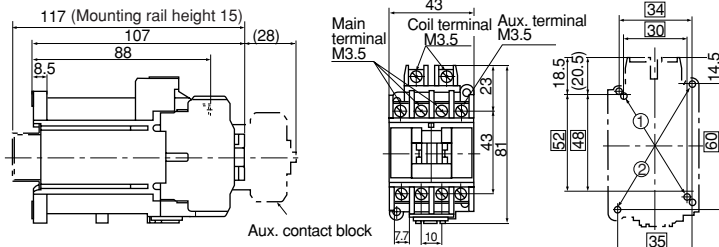

Mass:0.55kg

#### ■ Wiring diagrams

Auxiliary contact

1NO

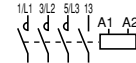

1NC

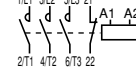

#### SC-05/G

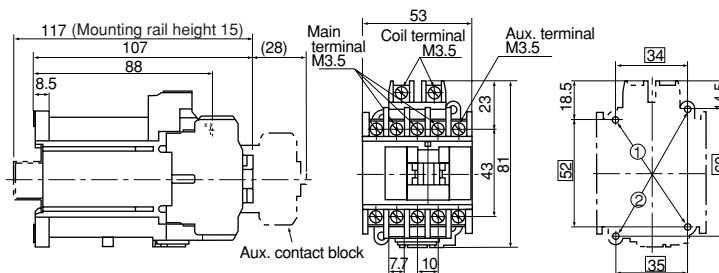

Mass:0.58kg

2NO

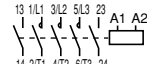

1NO+1NC

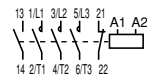

2NC

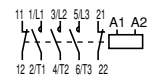

#### SC-4-0/G, SC-4-1/G

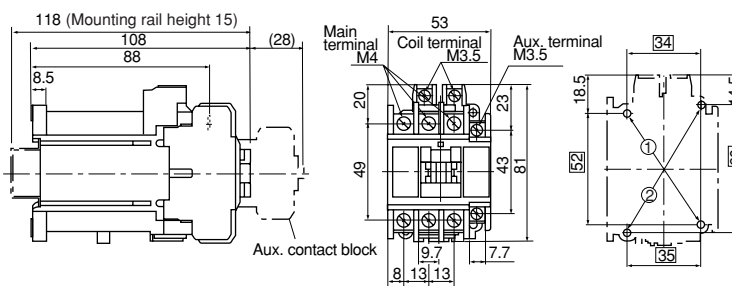

Mass:0.6kg

1NO

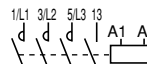

1NC

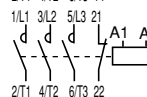

#### SC-5-1/G

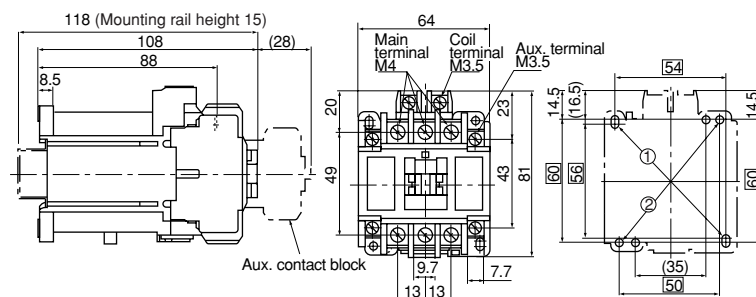

Mass:0.62kg

2NO

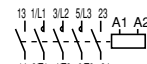

1NO+1NC

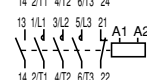

2NC

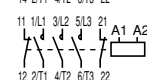

Note: Use the two mounting holes on a diagonal line to mount a contactor.  
Mounting holes indicated by ① are compatible with those of SRC type.  
Mounting holes indicated by ② are compatible with IEC standard

■ Dimensions  
 DC operated contactors  
**SC-N1/G, SC-N2/G**

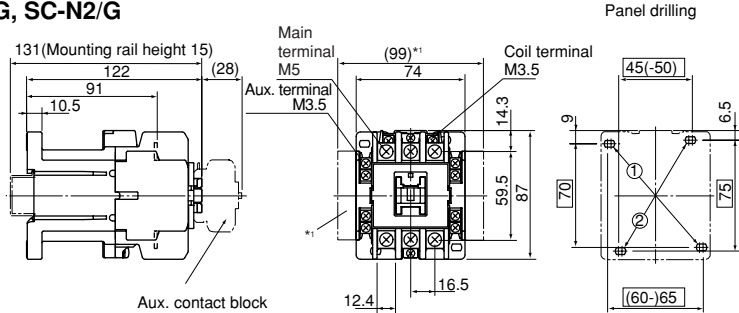

Mass: 0.82kg

\*1 For two side mounting aux. contact blocks mounted

**SC-N2S/G, SC-N3/G**

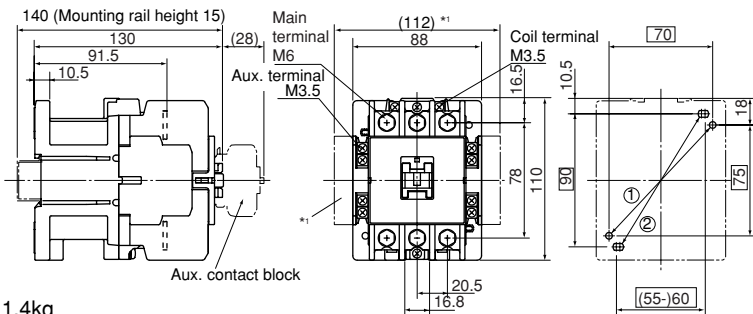

Mass: 1.4kg

\*1 For two side mounting aux. contact blocks mounted

■ Wiring diagrams  
**SC-N1/G to SC-N3/G**



\*1 In case of auxiliary contact 4NO+4NC

DC operated starters  
**SW-03/G3H, SW-0/G3H**

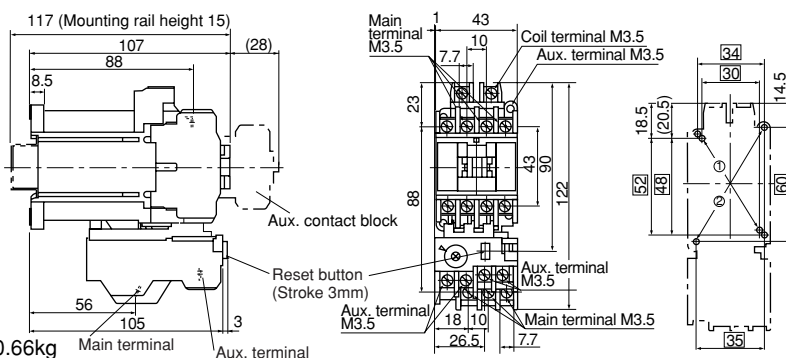

Mass: 0.66kg

**SW-05/G3H**

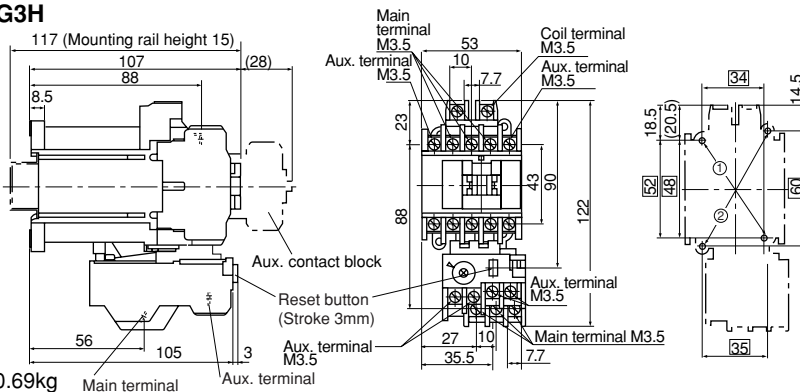

Mass: 0.69kg

■ Wiring diagrams

Auxiliary contact

1NO

1NC

2NO

1NO+1NC

2NC

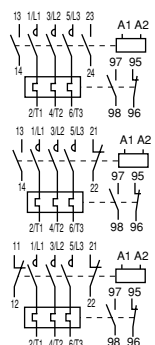
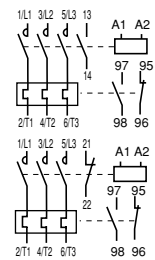

Note: Use the two mounting holes on a diagonal line to mount a contactor.  
 Mounting holes indicated by ① are compatible with those of SRC type.  
 Mounting holes indicated by ② are compatible with IEC standard

# Magnetic Contactors and Starters

## SC and SW series

### DC operated

#### ■ Dimensions

#### DC operated starters

#### SW-4-0/G3H, SW-4-1/G3H

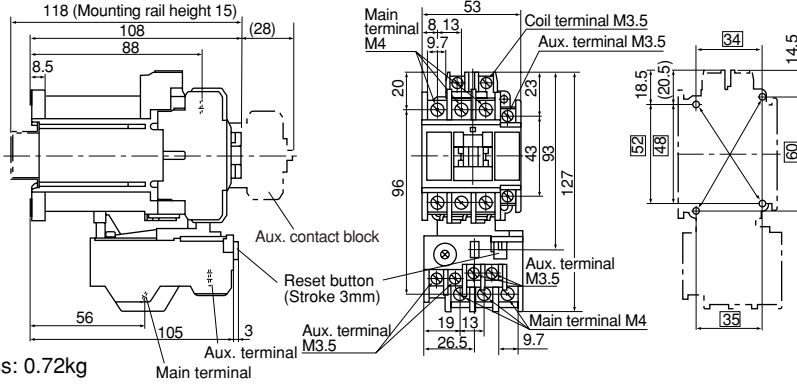

Mass: 0.72kg

#### SW-5-1/G3H

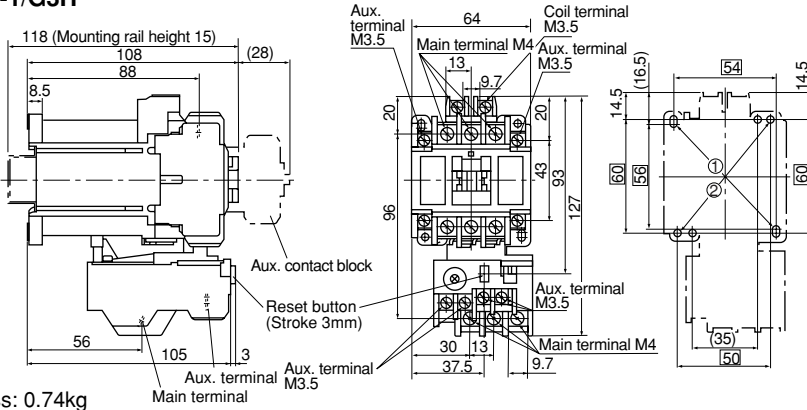

Mass: 0.74kg

#### SW-N1/G3H, SW-N2/G3H

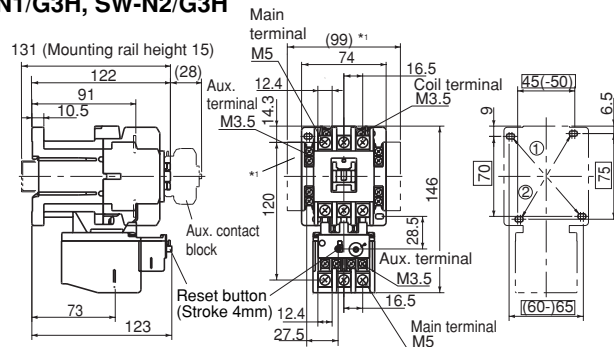

Mass: 1kg

#### SW-N2S/G3H, SW-N3/G3H

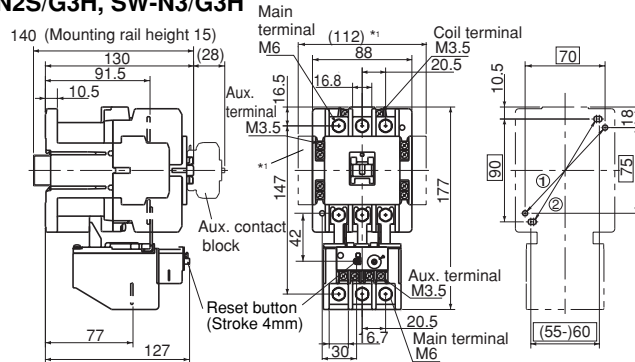

Mass: 1.6kg

#### ■ Wiring diagrams

Auxiliary contact

1NO

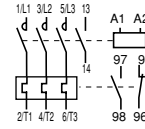

1NC

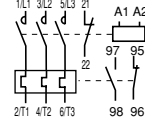

2NO

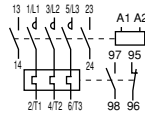

1NO+1NC

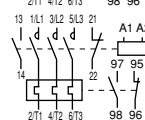

2NC

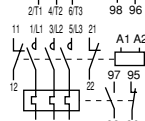

#### ■ Wiring diagrams

#### SW-N1/G3H to SW-N3/G3H

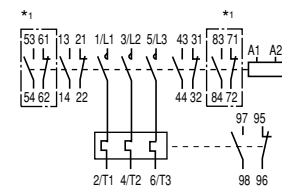

\*1 In case of auxiliary contact 4NO+4NC

Note: • Use the two mounting holes on a diagonal line to mount a contactor.  
 Mounting holes indicated by ① are compatible with those of SRC type.  
 Mounting holes indicated by ② are compatible with IEC standard  
 \*1 For two side mounting aux. contact blocks mounted  
 \*2 For front mounting aux. contact blocks mounted



■ Dimensions  
 DC operated contactors

**SC-N1/SE, SC-N2/SE**

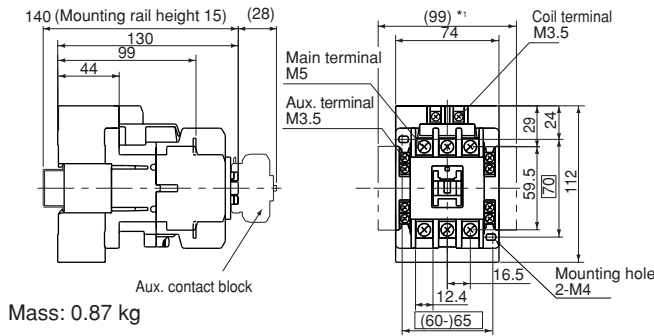

**SC-N4/SE**

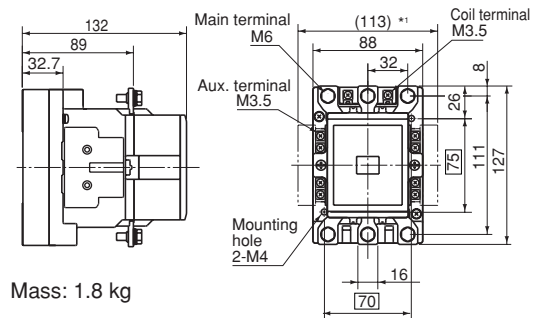

**SC-N2S/SE, SC-N3/SE**

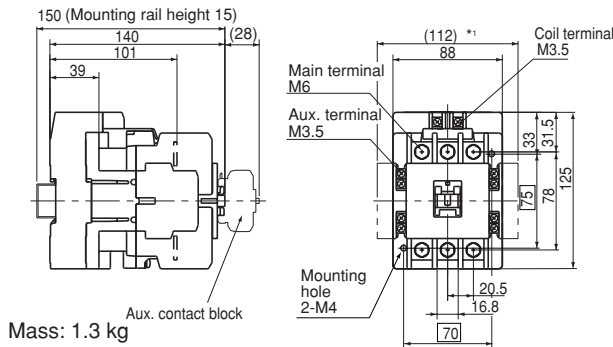

■ Wiring diagrams  
 SC-N1/SE to SC-N4/SE

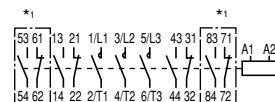

\*<sup>1</sup> In case of auxiliary contact 4NO+4NC

Dimension for SC-N5 to SC-N16 types  
 Same as standard open type

[See page 01/35, 01/36](#)

DC operated starters

**SW-N1/SE3H, SW-N2/SE3H**

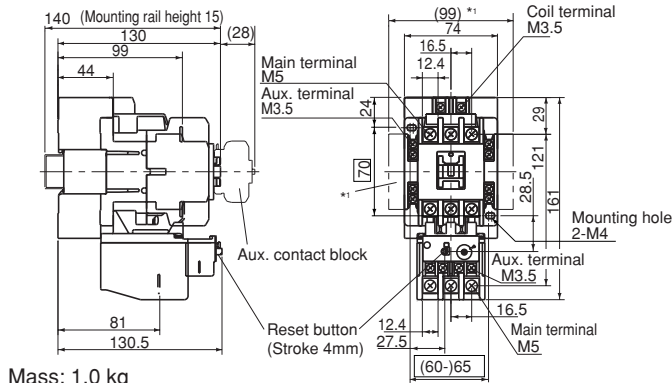

**SW-N4/SE3H**

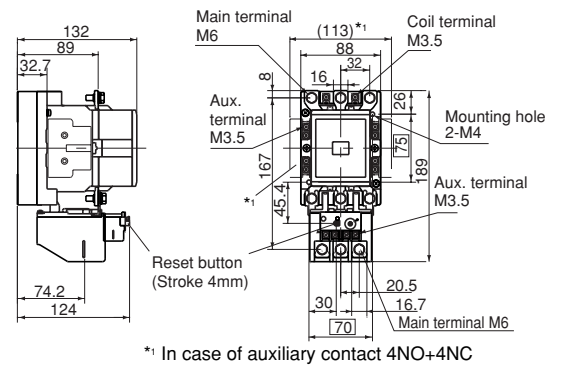

**SW-N2S/SE3H, SW-N3/SE3H**

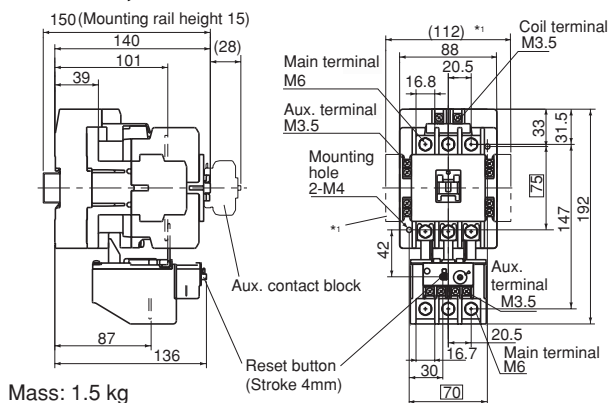

■ Wiring diagrams  
 SW-N1/SE3H to SW-N4/SE3H

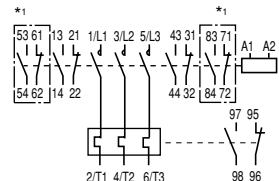

\*<sup>1</sup> In case of auxiliary contact 4NO+4NC

Dimension for SW-N5/3H to SW-N14/3H types  
 Same as standard open type

[See page 01/39, 01/40](#)

Note: \*<sup>1</sup> For two side mounting aux. contact blocks mounted

# Magnetic Contactors and Starters

## SC and SW series

### OFF-delay release

#### OFF-delay release type

##### ■ Description

This type contactor consists of DC-operated contactor and off-delay release unit, and the contacts are released with a delay of 1-4 or 1-5 seconds after the coil has been de-energized. When the standard type contactor suffers an instantaneous voltage drop

in the AC power supply or a power failure takes place the operating coils are de-energized and the reclosing of the contacts must be carried out every time. The off-delay release contactor is so designed that in the event of a brief power outage the coil will not release the contacts and the power is maintained making reclosing action unnecessary.

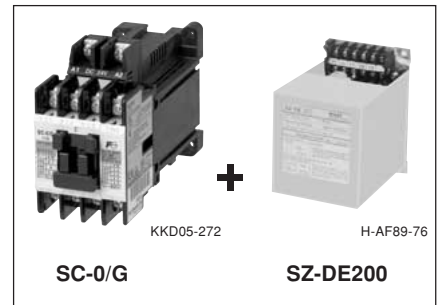

#### ■ Combination of OFF-delay release units and contactors

Contactor Type	Ordering code	Starter (3-element)		OFF-delay release unit	
		Type	Ordering code	Type	Ordering code
SC-03/G	SC11AG-■10	SW-03/G3H	SC11AGN-■10T□D	<b>SZ-DE</b> □	SZ1DE□
SC-0/G	SC13AG-■10	SW-0/G3H	SC13AGN-■10T□D		
SC-05/G	SC14AG-■11	SW-05/G3H	SC14AGN-■11T□D		
SC-4-0/G	SC18AG-■10	SW-4-0/G3H	SC18AGN-■10T□D		
SC-4-1/G	SC19AG-■10	SW-4-1/G3H	SC19AGN-■10T□D		
SC-5-1/G	SC20AG-■11	SW-5-1/G3H	SC20AGN-■11T□D		
SC-N1/G	SC25BAG-■22	SW-N1/G3H	SC25BAGN-■22T□D	<b>SZ-N1/GDE</b>	SZ2N1GDE-□
SC-N2/G	SC35BAG-■22	SW-N2/G3H	SC35BAGN-■22T□D	<b>SZ-N1/GDE</b>	SZ2N1GDE-□
SC-N2S/G	SC50BAG-■22	SW-N2S/G3H	SC50BAGN-■22T□D	<b>SZ-N2S/GDE</b>	SZ2N2SGDE-□
SC-N3/G	SC65BAG-■22	SW-N3/G3H	SC65BAGN-■22T□D	<b>SZ-N2S/GDE</b>	SZ2N2SGDE-□
SC-N4/SE	SC80BAS-■22	SW-N4/SE3H	SC80BASN-■22T□D	<b>SZ-N5/DE</b>	SZ2N5DE-□
SC-N5	SC93BAA-■22	SW-N5/3H	SC93BAAN-■22T□D	<b>SZ-N5/DE</b>	SZ2N5DE-□
SC-N6	SC1CBAA-■22	SW-N6/3H	SC1CBAAN-■22T□D	<b>SZ-N6/DE</b>	SZ2N6DE-□
SC-N7	SC1FBAA-■22	SW-N7/3H	SC1FBAAN-■22T□D	<b>SZ-N6/DE</b>	SZ2N6DE-□
SC-N8	SC1JBAA-■22	SW-N8/3H	SC1JBAAAN-■22T□D	<b>SZ-N8/DE</b>	SZ2N8DE-□
SC-N10	SC2CBAA-■22	SW-N10/3H	SC2CBAAN-■22T□D	<b>SZ-N8/DE</b>	SZ2N8DE-□
SC-N11	SC3ABAA-■22	SW-N11/3H	SC3ABAAN-■22T□D	<b>SZ-N11/DE</b>	SZ2N11DE-□
SC-N12	SC4ABAA-■22	SW-N12/3H	SC4ABAAN-■22T□D	<b>SZ-N11/DE</b>	SZ2N11DE-□
SC-N14	SC6ABAA-■22	SW-N14/3H	SC6ABAAN-■22T□D	<b>SZ-N14/DE</b>	SZ2N14DE-□

- Notes: 1. For contactor and starter.  
Enter the coil voltage code in the ■ mark.  
Enter the thermal overload relay ampere setting range code in the □ mark.  
2. For off-delay release unit.  
Enter the control voltage code in the □ mark.

#### ● OFF-delay release unit ordering code

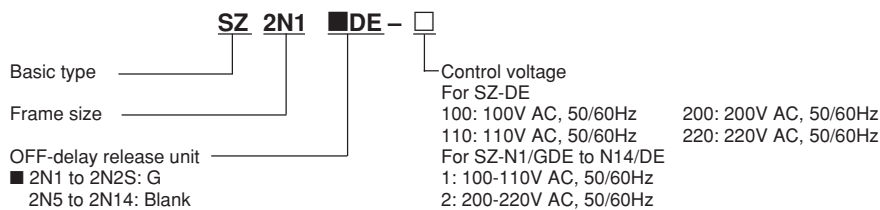

Note: If OFF-delay release contactors (starters) having capacities of frame size 03 to N3 are required the DC operated contactors (starters) will be combined with the OFF-delay release unit. When ordering make sure that the input voltage (AC) of the OFF-delay release unit is equal to the operating voltage (DC) of the contactors (starters).

Example:  
SZ-N5/DE 100V AC 50Hz+SC-N5 100V DC  
(OFF-delay release unit) + (Contactor)

#### ■ Performance data

Frame	Hold time	Making/breaking capacity	Operating cycles per hour	Life expectancy (operations)	
				Electrical	Mechanical
<b>03/G to 5-1/G</b>	1-5 sec.	10×le / 8×le	600	2 million*1	10 million
<b>N1/G, N2/G</b>	1-5 sec.	10×le / 8×le	600	2 million	10 million
<b>N2S/G, N3/G</b>	1-5 sec.	10×le / 8×le	600	2 million	5 million
<b>N4/SE</b>	1-4 sec.	10×le / 8×le	600	1 million	5 million
<b>N5 to N11</b>	1-4 sec.	10×le / 8×le	600	1 million	5 million
<b>N12</b>	1-4 sec.	10×le / 8×le	600	500,000	5 million
<b>N14</b>	1-4 sec.	10×le / 8×le	600	500,000	5 million

le: Rated operational current  
Capacitor life: 100,000 operations  
\*1 Frame size 4-0: 1.5 million  
Conforming to Class AC-3, IEC 60947-4-1

#### OFF-delay release unit

##### ■ Wiring diagrams SZ-DE100, 110, 200, 220 SZ-N1/GDE, N2S/GDE

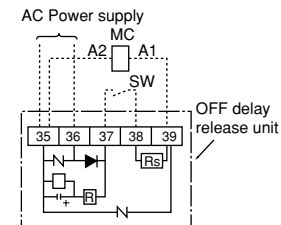

##### SZ-N5/DE to N14/DE

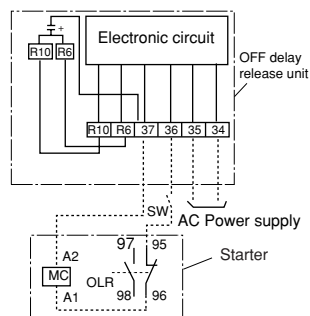

#### ■ Dimensions, mm SZ-DE100, 110, 200, 220 SZ-N1/GDE, N2S/GDE

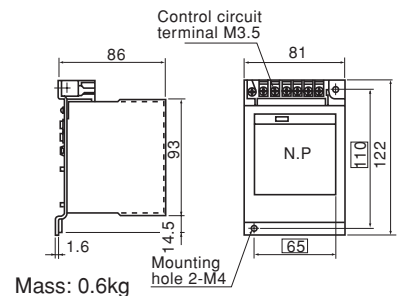

##### SZ-N5/DE to N14/DE

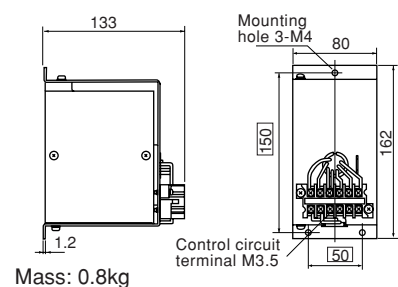

**Contactors and starters with extra pick-up operating coil**

■ **Description**

Generally, if the operating coil voltage of the contactor is within 85%–110% of its rated value normal operation can be expected. However, should the power source have a low capacity or if the supply point is some distance away from the power source a voltage drop can be expected and voltage may fall below 85% of its rated value under motor starting or similar conditions. Direct-on-line starting under these circumstances may result in poor starter performance, contacts welding together and coils overheating. The FUJI U-type contactors are provided with an extra operating coil which performs correctly even if the voltage is only 75% of its rated value. This starter is recommended for use in locations

where reduced voltage conditions are met.

Standard types for frame sizes N5 and above can be used as the contactor or starter with extra pick-up operating coil. Enclosed type starters (03 to N4) are also available.

■ **Ratings:** See page 01/28.

■ **Coil voltage:** See page 01/30.

■ **Dimensions:**

Same as standard type.

See page 01/34, 01/35.

■ **Thermal overload relay:**

See page 01/97.

■ **Ordering information**

Specify the following:

1. Ordering code
2. Motor ratings: Voltage, frequency, capacity (kW) and full load current.
3. Operating coil voltage code

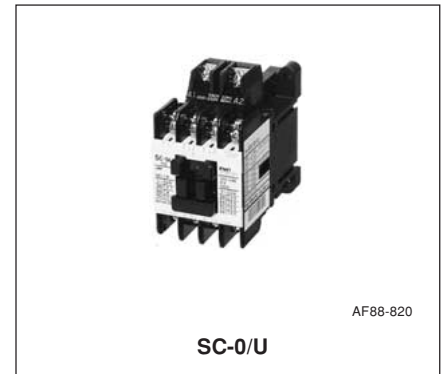

■ **Coil characteristics**

Contactor Type	Ordering code	Starter (3-element)		Aux. contact		Power consumption		Pick-up voltage (V)		Drop-out voltage (V)	
		Type	Ordering code	NO	NC	Inrush (VA)	Sealed (VA)	200V 50Hz	220V 60Hz	200V 50Hz	220V 60Hz
SC-03/U	SC11AU-■10	SW-03/U3H	SC11AUN-■10T□□	1	— *1	120	15	93–115	102–124	58–88	66–96
SC-0/U	SC13AU-■10	SW-0/U3H	SC13AUN-■10T□□	1	— *1	120	15	93–115	102–124	58–88	66–96
SC-05/U	SC14AU-■11	SW-05/U3H	SC14AUN-■11T□□	1	1 *2	120	15	93–116	103–126	60–90	70–99
SC-4-0/U	SC18AU-■10	SW-4-0/U3H	SC18AUN-■10T□□	1	— *1	120	15	100–120	110–130	63–90	73–100
SC-4-1/U	SC19AU-■10	SW-4-1/U3H	SC19AUN-■10T□□	1	— *1	120	15	100–120	110–130	63–90	73–100
SC-5-1/U	SC20AU-■11	SW-5-1/U3H	SC20AUN-■11T□□	1	1 *2	120	15	99–121	110–130	64–96	74–102
SC-5-1/U	SC20AU-■22	SW-5-1/U3H	SC20AUN-■22T□□	2	2	120	15	99–121	110–130	64–96	74–102
SC-N1/U	SC25BAU-■22	SW-N1/U3H	SC25BAUN-■22T□□	2	2 *3	130	13	104–122	114–132	68–88	80–98
SC-N2/U	SC35BAU-■22	SW-N2/U3H	SC35BAUN-■22T□□	2	2 *3	130	13	104–122	114–132	68–88	80–98
SC-N2S/U	SC50BAU-■22	SW-N2S/U3H	SC50BAUN-■22T□□	2	2 *3	195	14.3	104–120	118–134	72–90	84–102
SC-N3/U	SC65BAU-■22	SW-N3/U3H	SC65BAUN-■22T□□	2	2 *3	195	14.3	104–120	118–134	72–90	84–102
SC-N4/U	SC80BAU-■22	SW-N4/U3H	SC80BAUN-■22T□□	2	2 *3	235	20	104–120	118–134	72–90	84–102

Notes: 1 The standard SC-N5 to SC-N16 types are provided with the SUPER MAGNET which holds without chattering even if the line voltage drops to 65% of its rated value, so preventing the troubles such as contact welding or coil burning.

2. \*1 Auxiliary contact 1NC is available on request.

\*2 Auxiliary contact 2NO or 2NC is available on request.

\*3 Auxiliary contact 4NO+4NC is available on request

3. Enter the coil voltage code in the ■ mark.

Enter the thermal overload relay ampere setting range code in the □ mark.

■ **Performance data**

Type	Make and break capacity	Operating cycles per hour	Life expectancy (operations)		
			Electrical	Mechanical	
Contactor	Starter				
SC-03/U	SW-03/U3H	IEC60947-4-1 class AC-3	1800	2 million	2.5 million
SC-0/U	SW-0/U3H	Make: 10×Ie	1800	2 million	2.5 million
SC-05/U	SW-05/U3H	Break: 8×Ie	1800	2 million	2.5 million
SC-4-0/U	SW-4-0/U3H	(Ie : Operational current)	1800	2 million	2.5 million
SC-4-1/U	SW-4-1/U3H		1800	2 million	2.5 million
SC-5-1/U	SW-5-1/U3H		1800	2 million	2.5 million
SC-N1/U	SW-N1/U3H		1200	2 million	2.5 million
SC-N2/U	SW-N2/U3H		1200	1 million	1 million
SC-N2S/U	SW-N2S/U3H		1200	1 million	1 million
SC-N3/U	SW-N3/U3H		1200	1 million	1 million
SC-N4/U	SW-N4/U3H		1200	1 million	1 million

# Magnetic Contactors

## SC series

### Mechanical latch

#### Mechanical latch contactors

Up to 315kW 440 Volts AC 3-phase

#### Description

Mechanical latch contactors are used where operating sequence continuity must be maintained regardless of any outside interruptions, such as voltage failure or instantaneous voltage drop. Typical applications are for electric furnaces, machine tool circuits, standby power supply and normal power changeover circuits in hospitals, schools and office buildings. These contactors are provided with two coils. One is CC (Closing Coil) and the other is TC (Tripping Coil). An interlocking circuit is provided between the CC coil and the TC coil. Since a coil voltage is not applied during operation it is extremely quiet. Power consumption can also be saved.



#### Performance data

Frame size	Making capacity	Breaking capacity	Operating cycles per hour	Life expectancy (operations)	
				Electrical	Mechanical
03/V to 5-1/V, 03/VG to 5-1/VG N1/VS to N3/VS N4/VS to N12/VS N14/VS	10×Ie	8×Ie	1200	500,000	1 million
	10×Ie	8×Ie	600	500,000	500,000
	10×Ie	8×Ie	600	250,000	250,000
	10×Ie	8×Ie	600	100,000	100,000

Notes: Ie: Rated operational current.

- Mechanical latch units cannot be sold separately. Such units are only sold attached to contactors.
- Do not detach mechanical latch units from contactors and do not make modifications such as attaching mechanical latch units to other contactors.

#### Types and ratings

##### AC, AC/DC operated

Max. motor capacity (kW)	Rated operational current (A)		Rated thermal current Ith (A)	Non-reversing			Reversing					
	200V	380V		Type	Aux. contact NO	NC	Ordering code	Type	Aux. contact NO	NC	Ordering code	
	240V	440V		200V	380V	240V	440V					
2.5	4	11	9	20	SC-03/V	–	–	SC11AV-■00	SC03RM/V	–	–	SC11RV-■00
3.5	5.5	13	12	20	SC-0/V	–	–	SC13AV-■00	SC0RM/V	–	–	SC13RV-■00
3.5	5.5	13	12	20	SC-05/V	1	–	SC14AV-■10	SC05RM/V	2	–	SC14RV-■10
3.5	5.5	13	12	20		–	1	SC14AV-■01		–	2	SC14RV-■01
4.5	7.5	18	16	25	SC-4-0/V	–	–	SC18AV-■00	SC-4-0RM/V	–	–	SC18RV-■00
5.5	11	22	22	32	SC-4-1/V	–	–	SC19AV-■00	SC-4-1RM/V	–	–	SC19RV-■00
5.5	11	22	22	32	SC-5-1/V	1	–	SC20AV-■10	SC-5-1RM/V	2	–	SC20RV-■10
5.5	11	22	22	32		–	1	SC20AV-■01		–	2	SC20RV-■01
5.5	11	22	22	32		1	2	SC20AV-■12		2	4	SC20RV-■12
7.5	15	32	32	50	SC-N1/VS	2	2	SC25BAE-■22	SC-N1RM/VS	4	4	SC25BRE-■22
11	18.5	40	40	60	SC-N2/VS	2	2	SC35BAE-■22	SC-N2RM/VS	4	4	SC35BRE-■22
15	22	50	50	80	SC-N2S/VS	2	2	SC50BAE-■22	SC-N2SRM/VS	4	4	SC50BRE-■22
18.5	30	65	65	100	SC-N3/VS	2	2	SC65BAE-■22	SC-N3RM/VS	4	4	SC65BRE-■22
22	40	80	80	135	SC-N4/VS	1	2	SC80BAE-■12	SC-N4RM/VS	2	4	SC80BRE-■12
30	55	105	105	150	SC-N5/VS	1	2	SC93BAE-■12	SC-N5RM/VS	2	4	SC93BRE-■12
37	60	125	125	150	SC-N6/VS	1	2	SC1CBAE-■12	SC-N6RM/VS	2	4	SC1CBRE-■12
45	75	150	150	200	SC-N7/VS	1	2	SC1FBAE-■12	SC-N7RM/VS	2	4	SC1FBRE-■12
55	90	180	180	260	SC-N8/VS	1	2	SC1JBAE-■12	SC-N8RM/VS	2	4	SC1JBRE-■12
65	110	220	220	260	SC-N10/VS	1	2	SC2CBAE-■12	SC-N10RM/VS	2	4	SC2CBRE-■12
90	160	300	300	350	SC-N11/VS	1	2	SC3ABAE-■12	SC-N11RM/VS	2	4	SC3ABRE-■12
120	220	400	400	450	SC-N12/VS	1	2	SC4ABAE-■12	SC-N12RM/VS	2	4	SC4ABRE-■12
180	315	600	600	660	SC-N14/VS	1	2	SC6ABAE-■12	SC-N14RM/VS	2	4	SC6ABRE-■12

Notes: Since SC-N1/VS to SC-N14/VS are provided with the SUPER MAGNET they operate on both AC or DC.

Enter the coil rated voltage code in the ■ mark, [see page 01/27](#)

##### DC operated

Max. motor capacity (kW)	Rated operational current (A)		Rated thermal current Ith (A)	Non-reversing			Reversing					
	200V	380V		Type	Aux. contact NO	NC	Ordering code	Type	Aux. contact NO	NC	Ordering code	
	240V	440V		200V	380V	240V	440V					
2.5	4	11	9	20	SC-03/VG	–	–	SC11AD-■00	SC03RM/VG	–	–	SC11RD-■00
3.5	5.5	13	12	20	SC-0/VG	–	–	SC13AD-■00	SC0RM/VG	–	–	SC13RD-■00
3.5	5.5	13	12	20	SC-05/VG	1	–	SC14AD-■10	SC05RM/VG	2	–	SC14RD-■10
3.5	5.5	13	12	20		–	1	SC14AD-■01		–	2	SC14RD-■01
4.5	7.5	18	16	25	SC-4-0/VG	–	–	SC18AD-■00	SC-4-0RM/VG	–	–	SC18RD-■00
5.5	11	22	22	32	SC-4-1/VG	–	–	SC19AD-■00	SC-4-1RM/VG	–	–	SC19RD-■00
5.5	11	22	22	32	SC-5-1/VG	1	–	SC20AD-■10	SC-5-1RM/VG	2	–	SC20RD-■10
5.5	11	22	22	32		–	1	SC20AD-■01		–	2	SC20RD-■01
5.5	11	22	22	32		1	2	SC20AD-■12		2	4	SC20RD-■12

Note: Enter the coil rated voltage code in the ■ mark, [see page 01/27](#)

■ **Operating method**

**Closing**

When the closing coil is energized the latch mechanism interlocks to latch and the NC contact connected in series with the closing coil opens and the coil is de-energized.

**Tripping**

When the tripping coil is energized the latch is released and tripping is carried out by means of the back spring. At this time the NO contact connected in series with the tripping coil opens.

■ **Operating notes**

- When carrying out a sequence operating check make sure that the load circuit is open.
- The electrical signal time for closing and tripping should be 0.3 sec. or more.
- Tripping coil is short time rated. Tripping coil: Max. 15 seconds
- In the cases of 03/V to N3/VS versions the contacts cannot be replaced. In the cases of those versions above N4/VS the contacts can be replaced.
- Both closing and tripping circuits should be electrically interlocked with each other.

■ **Ordering information**

Specify the following:

1. Ordering code
2. Auxiliary contact arrangement: In the case of the frame size 05/V, 05/VG, 5-1/V or 5-1/VG, specify the contact arrangement.
3. Closing and tripping coil  
 For AC operated: Voltage and frequency  
 For DC operated: Voltage

■ **Coil characteristics**

**AC operated**

Type	Power consumption		Coil voltage *
	Closing (VA)	Tripping (VA)	
SC-03/V	95	150	100/100–110V AC 50/60Hz
SC-0/V	95	150	
SC-05/V	95	150	
SC-4-0/V	95	150	
SC-4-1/V	95	150	
SC-5-1/V	95	150	200/200–220V AC 50/60Hz
SC-N1/VS	100	140	
SC-N2/VS	100	140	
SC-N2S/VS	115	140	
SC-N3/VS	115	140	
SC-N4/VS	161	266	100–110V AC 50/60Hz
SC-N5/VS	161	266	
SC-N6/VS	229	266	
SC-N7/VS	229	266	
SC-N8/VS	273	385	
SC-N10/VS	273	385	
SC-N11/VS	490	385	
SC-N12/VS	490	385	
SC-N14/VS	500	660	

**DC operated**

Type	Power consumption		Coil voltage *
	Closing (W)	Tripping (W)	
SC-03/VG	7	150	100, 110V DC
SC-0/VG	7	150	
SC-05/VG	7	150	
SC-4-0/VG	7	150	200, 220V DC
SC-4-1/VG	7	150	
SC-5-1/VG	7	150	
SC-N1/VS	95	150	100–110V DC
SC-N2/VS	95	150	
SC-N2S/VS	110	150	
SC-N3/VS	110	150	
SC-N4/VS	153	198	
SC-N5/VS	153	198	
SC-N6/VS	216	198	
SC-N7/VS	216	198	
SC-N8/VS	260	294	100–110V DC
SC-N10/VS	260	294	
SC-N11/VS	515	294	
SC-N12/VS	515	294	
SC-N14/VS	500	660	

Notes: \*Other coil voltage can be supplied.  
 SC-03/V to 5-1/V: 24 to 220V AC 50/60Hz  
 SC-N1/VS to N12/VS: 24 to 220V AC 50/60Hz  
 SC-N14/VS: 100 to 220V AC 50/60Hz

Notes: \*Other coil voltage can be supplied.  
 SC-03/VG to 5-1/VG: 24 to 220V DC  
 SC-N1/VS to N12/VS: 24 to 220V DC  
 SC-N14/VS: 100 to 220V DC

■ **Operating circuit**

**SC-03/V to 5-1/V**  
**SC-03/VG to 5-1/VG**

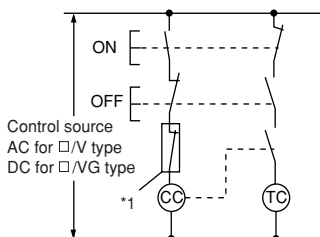

\*1 NC contact for closing coil to be de-energized

**SC-N1/VS to N3/VS**

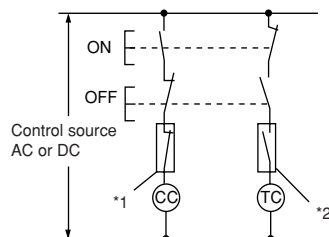

\*1 NC contact for closing coil to be de-energized.  
 \*2 NO contact for tripping coil to be de-energized.

**SC-N4/VS to N14/VS**

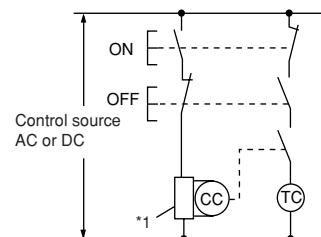

\*1 Solid-state circuit for closing coil to be controlled. (NC solid-state contact)

# Magnetic Contactors

## SC series

### Mechanical latch

#### Mechanical latch type contactors

##### ■ Dimensions, mm

SC-03/V to 5-1/V  
SC-03/VG to 5-1/VG

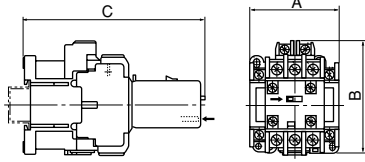

SC-N4/VS to N7/VS

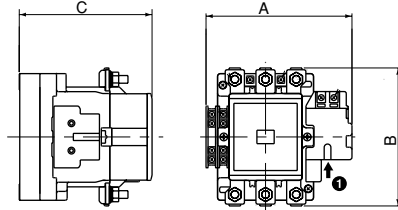

SC-N14/VS

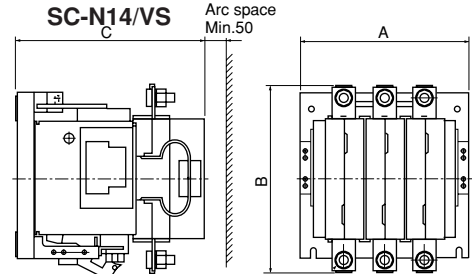

SC-N1/VS to N3/VS

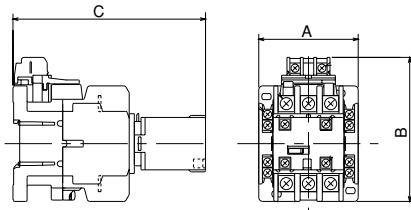

SC-N8/VS to N12/VS

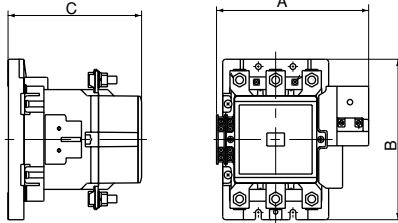

Dimensions for reference only.  
Confirm before construction begins.

Type	A	B	C	Mass (kg)
SC-03/V, 0/V	43	81	128	0.43
SC-05/V	53	81	128	0.45
SC-4-0/V, 4-1/V	53	81	129	0.47
SC-5-1/V	64	81	129	0.49
SC-03/VG, 0/VG	43	81	155	0.66
SC-05/VG	53	81	155	0.69
SC-4-0/VG, 4-1/VG	53	81	156	0.71
SC-5-1/VG	64	81	156	0.73

Type	A	B	C	Mass (kg)
SC-N1/VS, N2/VS	74	108	143.5	0.75
SC-N2S/VS, N3/VS	88	130	158	1.25
SC-N4/VS, N5/VS	140	127	132	2.3
SC-N6/VS	152	144	138	2.9
SC-N7/VS	167.5	156	140	3.2
SC-N8/VS, N10/VS	199	209	174	5.7
SC-N11/VS, N12/VS	215.5	240	195	8.6
SC-N14/VS	290	332	331	37

##### ■ Wiring diagrams

SC-03/V, 0/V, 4-0/V, 4-1/V  
SC-03/VG, 0/VG, 4-0/VG, 4-1/VG

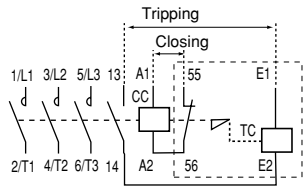

SC-5-1/V, /VG (Aux. contact 1NO+2NC)

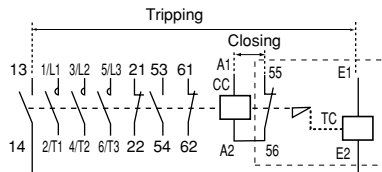

SC-N14/VS

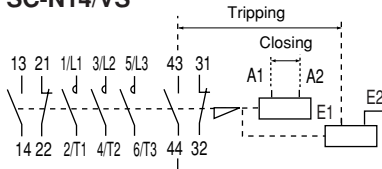

SC-05/V, 5-1/V SC-05/VG, 5-1/VG  
(Aux. contact 1NO)

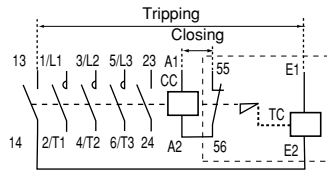

SC-N1/VS to N3/VS

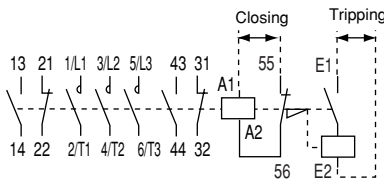

(Aux. contact 1NC)

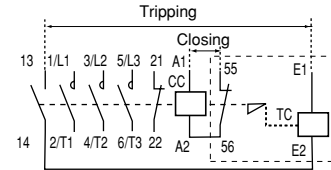

SC-N4/VS to N12/VS

CC: Closing coil  
TC: Tripping coil

Reversing mechanical latch contactors

■ Dimensions, mm  
SC-03RM/V to 5-1RM/V  
SC-03RM/VG to 5-1RM/VG

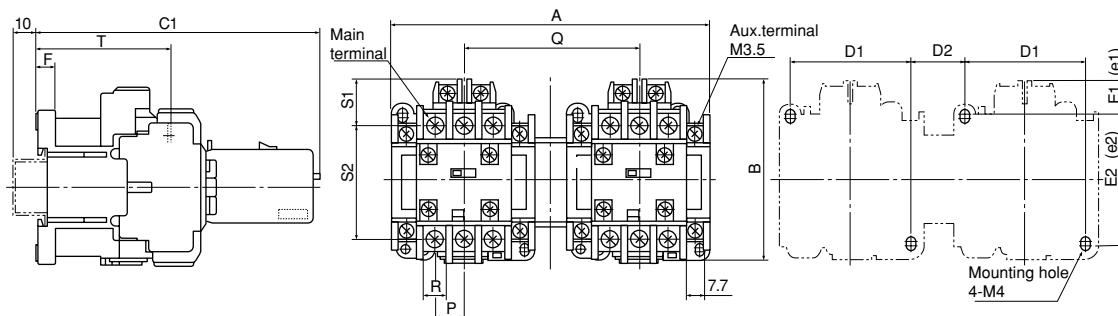

Type	Auxiliary contact	A	B	C1	D1	D2	E1(e <sub>1</sub> )	E2(e <sub>2</sub> )	F	P	Q	R	S1	S2	T	Main terminal	Mass (kg)
SC-03RM/V	—	99	81	128	34	22	18.5 (20.5)	52 (48)	8.5	10	56	7.7	23	43	61	M3.5	0.9
SC-0RM/V	—	99	81	128	34	22	18.5 (20.5)	52 (48)	8.5	10	56	7.7	23	43	61	M3.5	0.9
SC-05RM/V	2NO or 2NC	119	81	128	34	32	18.5 (20.5)	52 (48)	8.5	10	66	7.7	23	43	61	M3.5	0.94
SC-4-0RM/V	—	119	81	129	34	32	18.5 (20.5)	52 (48)	8.5	13	66	9.7	20	49	61	M4	0.98
SC-4-1RM/V	—	119	81	129	34	32	18.5 (20.5)	52 (48)	8.5	13	66	9.7	20	49	61	M4	0.98
SC-5-1RM/V	2NO or 2NC	141	81	129	54	23	14.5 (16.5)	60 (56)	8.5	13	77	9.7	20	49	61	M4	1.02
	2NO+4NC	165	81	129	54	23	14.5 (16.5)	60 (56)	8.5	13	77	9.7	20	49	61	M4	1.08
SC-03RM/VG	—	99	81	155	34	22	18.5 (20.5)	52 (48)	8.5	10	56	7.7	23	43	88	M3.5	1.36
SC-0RM/VG	—	99	81	155	34	22	18.5 (20.5)	52 (48)	8.5	10	56	7.7	23	43	88	M3.5	1.36
SC-05RM/VG	2NO or 2NC	119	81	155	34	32	18.5 (20.5)	52 (48)	8.5	10	66	7.7	23	43	88	M3.5	1.42
SC-4-0RM/VG	—	119	81	156	34	32	18.5 (20.5)	52 (48)	8.5	13	66	9.7	20	49	88	M4	1.46
SC-4-1RM/VG	—	119	81	156	34	32	18.5 (20.5)	52 (48)	8.5	13	66	9.7	20	49	88	M4	1.46
SC-5-1RM/VG	2NO or 2NC	141	81	156	54	23	14.5 (16.5)	60 (56)	8.5	13	77	9.7	20	49	88	M4	1.5
	2NO+4NC	165	81	156	54	23	14.5 (16.5)	60 (56)	8.5	13	77	9.7	20	49	88	M4	1.56

Fig. 1 SC-N1RM/VS to N3RM/VS

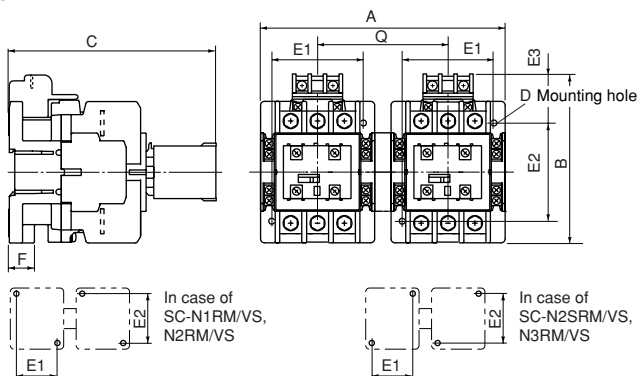

Fig. 2 SC-N4RM/VS to N12RM/VS

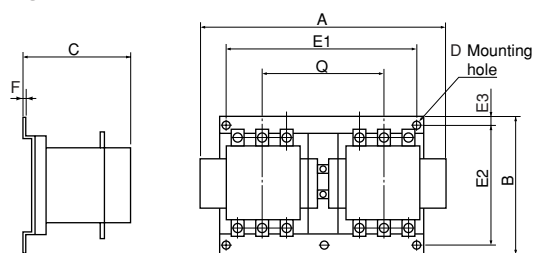
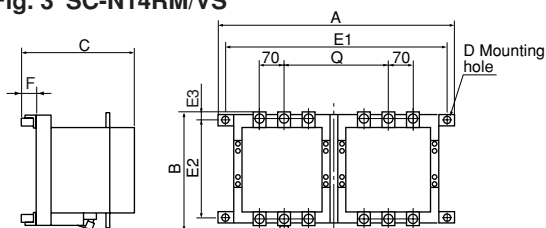

Fig. 3 SC-N14RM/VS



Type	A	B	C	D	E1	E2	E3	F	Q	Mass (kg)	Fig. No.
SC-N1RM/VS	161	108	143.5	4-M4	65	70	30	10.5	87	1.6	1
SC-N2RM/VS	161	108	143.5	4-M4	65	70	30	10.5	87	1.6	1
SC-N2SRM/VS	187	130	158	4-M4	70	75	38	10.5	100	2.6	1
SC-N3RM/VS	187	130	158	4-M4	70	75	38	10.5	100	2.6	1
SC-N4RM/VS	303	165	122	3-M5	200	150	7.5	1.6	135	5.0	2
SC-N5RM/VS	303	165	122	3-M5	200	150	7.5	1.6	135	5.0	2
SC-N6RM/VS	327	190	145	3-M5	220	175	7.5	1.6	147	6.7	2
SC-N7RM/VS	358	215	147	3-M6	260	200	7.5	2	162	8.1	2
SC-N8RM/VS	421	270	184	4-M6	300	250	10	2	177	13.0	2
SC-N10RM/VS	421	270	184	4-M6	300	250	10	2	177	13.0	2
SC-N11RM/VS	454	330	210	4-M8	300	300	15	2.3	192	21.4	2
SC-N12RM/VS	454	330	210	4-M8	300	300	15	2.3	192	21.4	2
SC-N14RM/VS	700	349	376	4-M10	650	250	41	45	324	80	3

Dimensions for reference only.  
Confirm before construction begins.

# Magnetic Contactors

## SC series

### Mechanical latch

#### Reversing mechanical latch contactors

##### ■ Wiring diagrams

SC-03RM/V, 0RM/V, 4-0RM/V, 4-1RM/V

SC-03RM/VG, 0RM/VG, 4-0RM/VG, 4-1RM/VG

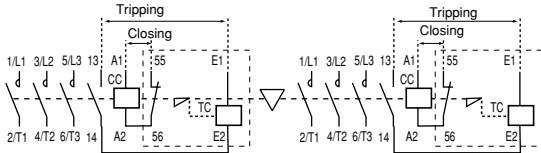

CC: Closing coil  
TC: Tripping coil

SC-05RM/V, 5-1RM/V  
SC-05RM/VG, 5-1RM/VG  
Auxiliary contact: 1NC×2

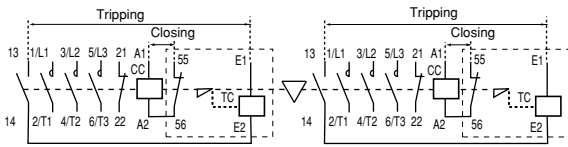

CC: Closing coil  
TC: Tripping coil

SC-N1RM/VS to N3RM/VS

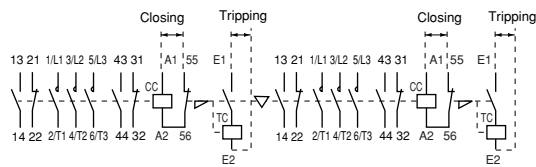

CC: Closing coil  
TC: Tripping coil

SC-N14RM/VS

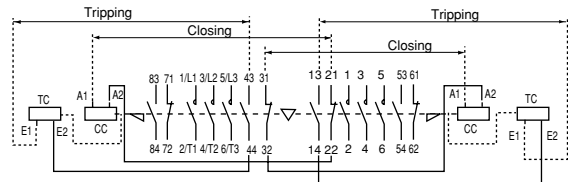

CC: Closing coil  
TC: Tripping coil

SC-05RM/V, 5-1RM/V

SC-05RM/VG, 5-1RM/VG

Auxiliary contact: 1NO×2

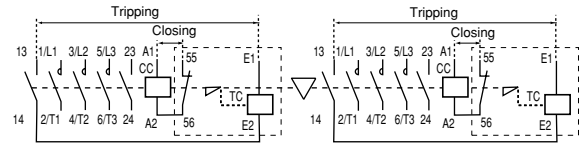

CC: Closing coil  
TC: Tripping coil

SC-5-1RM/V  
SC-5-1RM/VG  
Auxiliary contact: 2×(1NO+2NC)

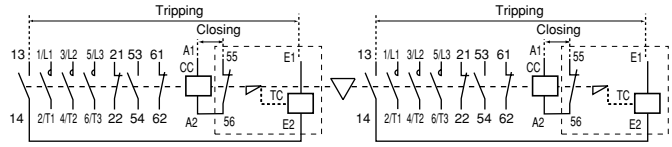

CC: Closing coil  
TC: Tripping coil

SC-N4RM/VS to N12RM/VS

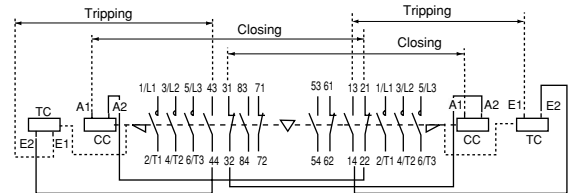

CC: Closing coil  
TC: Tripping coil



### Motor starters for heavy starting conditions

Up to 315kW 440 Volts 3-phase

#### ■ Description

This starter is designed for applications to those loads where the inrush current at the moment of starting persists for a long period, such as with blowers, winders, fans and centrifugal separators whose inertia force is large. In these cases the inrush current could last up to 7-8 sec., and would cause a standard type starter to misstrip. FUJI heavy load starters are highly suitable for such conditions and are provided with long time operating type thermal overload relays. In this type of

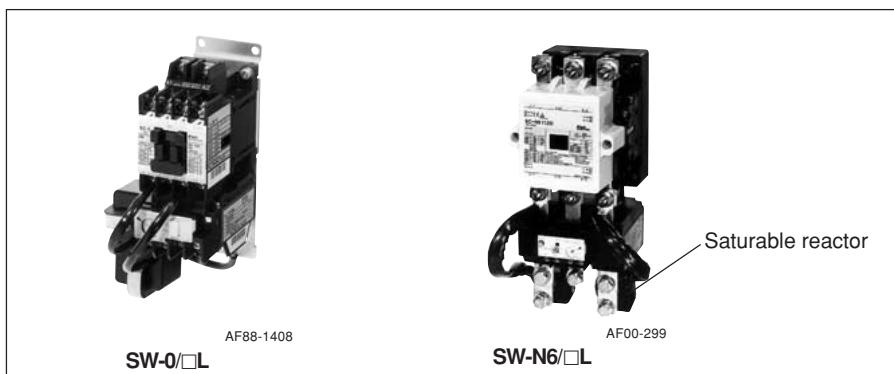

overload relay the small-sized saturable core reactors are connected in parallel with the heater elements. These divert the inrush current at the time of starting.

#### ■ Ordering information

Specify the following:

1. Ordering code
2. Overload relay setting range code
3. Operating coil voltage code
4. Auxiliary contact arrangement

#### ■ Types and ratings

Type	Ordering code	Aux. contact		Max. motor capacity (kW)		Operational current (A)		Combined thermal overload relay (3-element) Type
		NO	NC	200V 240V	380V 440V	200V 240V	380V 440V	
SW-03/3L	SC11AAF-■10T□	1	–	2.5	4	11	9	TR-0NL/3
SW-03/3L	SC11AAF-■01T□	–	1	2.5	4	11	9	TR-0NL/3
SW-0/3L	SC13AAF-■10T□	1	–	3.5	5.5	13	12	TR-0NL/3
SW-0/3L	SC13AAF-■01T□	–	1	3.5	5.5	13	12	TR-0NL/3
SW-05/3L	SC14AAF-■20T□	2	–	3.5	5.5	13	12	TR-0NL/3
SW-05/3L	SC14AAF-■11T□	1	1	3.5	5.5	13	12	TR-0NL/3
SW-05/3L	SC14AAF-■02T□	–	2	3.5	5.5	13	12	TR-0NL/3
SW-4-0/3L	SC18AAF-■10T□	1	–	4.5	7.5	18	16	TR-5-1NL/3
SW-4-0/3L	SC18AAF-■01T□	–	1	4.5	7.5	18	16	TR-5-1NL/3
SW-4-1/3L	SC19AAF-■10T□	1	–	5.5	11	22	22	TR-5-1NL/3
SW-4-1/3L	SC19AAF-■01T□	–	1	5.5	11	22	22	TR-5-1NL/3
SW-5-1/3L	SC20AAF-■20T□	2	–	5.5	11	22	22	TR-5-1NL/3
SW-5-1/3L	SC20AAF-■11T□	1	1	5.5	11	22	22	TR-5-1NL/3
SW-5-1/3L	SC20AAF-■02T□	–	2	5.5	11	22	22	TR-5-1NL/3
SW-5-1/3L	SC20AAF-■22T□	2	2	5.5	11	22	22	TR-5-1NL/3
SW-N1/3L	SC25BAAF-■22T□	2	2	7.5	15	32	32	TR-N2L/3
SW-N2/3L	SC35BAAF-■22T□	2	2	11	18.5	40	40	TR-N2L/3
SW-N2S/3L	SC50BAAF-■22T□	2	2	15	22	50	50	TR-N3L/3
SW-N3/3L	SC65BAAF-■22T□	2	2	18.5	30	65	65	TR-N3L/3
SW-N4/3L	SC80BAAF-■22T□	2	2	22	40	80	80	TR-N5L/3
SW-N5/3L	SC93BAAF-■22T□	2	2	30	55	105	105	TR-N5L/3
SW-N6/3L	SC1CBAAF-■22T□	2	2	37	60	125	125	TR-N6L/3
SW-N7/3L	SC1FBAAF-■22T□	2	2	45	75	150	150	TR-N7L/3
SW-N8/3L	SC1JBAAF-■22T□	2	2	55	90	180	180	TR-N10L/3
SW-N10/3L	SC2CBAAF-■22T□	2	2	65	110	220	220	TR-N10L/3
SW-N11/3L	SC3ABAAF-■22T□	2	2	90	160	300	300	TR-N11L/3
SW-N12/3L	SC4ABAAF-■22T□	2	2	120	220	400	400	TR-N12L/3
SW-N14/3L	SC6ABAAF-■22T□	2	2	180	315	600	600	TR-N14L/3

- Notes: 1. ■ Enter the operating coil voltage code.  
2. □ Enter the thermal overload relay ampere setting range code.  
3. Starters with 2-element overload relay are also available SW-□/2L.

# Magnetic Motor Starters

## SW series

### Heavy starting duty

#### ■ Dimensions, mm

SW-03/2L to 5-1/2L  
SW-03/3L to 5-1/3L

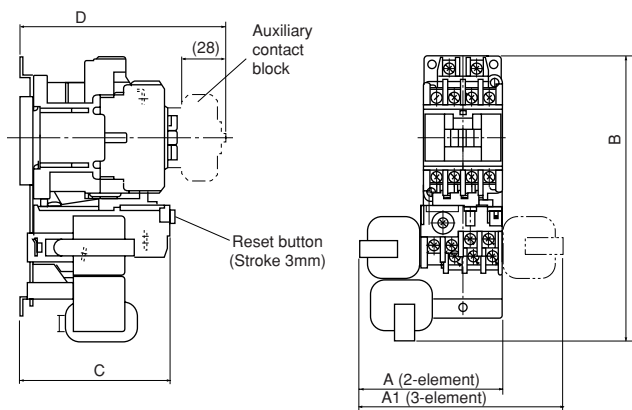

Type	2-element	3-element	A	A1	B	C	D *	Mass (kg)	
								2-element	3-element
SW-03/2L	SW-03/3L		79	115	157	83	113	0.62	0.72
SW-0/2L	SW-0/3L		79	115	157	83	113	0.62	0.72
SW-05/2L	SW-05/3L		84	120	157	84	114	0.64	0.74
SW-4-0/2L	SW-4-0/3L		88	124	157	83	114	0.66	0.76
SW-4-1/2L	SW-4-1/3L		88	124	157	83	114	0.66	0.76
SW-5-1/2L	SW-5-1/3L		89	124	157	83	114	0.69	0.79
SW-5-1/2L	SW-5-1/3L		89	124	157	83	114	0.71	0.81

C: Without front mounting auxiliary contact block

D: With front mounting auxiliary contact block

\* Mounted auxiliary contacts 2NO+2NC

#### SW-N1/2L, N2/2L SW-N1/3L, N2/3L

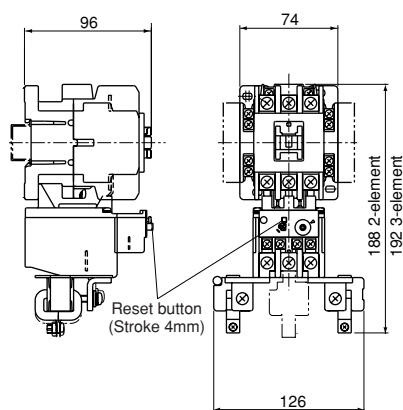

Mass: SW-N1/2L, N2/2L: 1.01kg  
SW-N1/3L, N2/3L: 1.13kg

#### SW-N2S/2L to SW-N7/2L SW-N2S/3L to SW-N7/3L

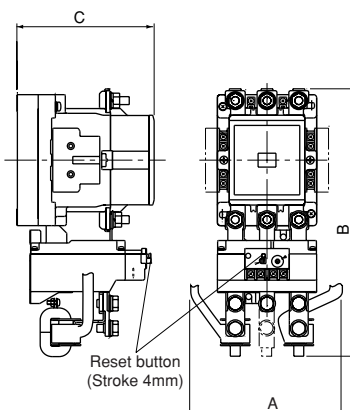

#### SW-N8/2L SW-N8/3L

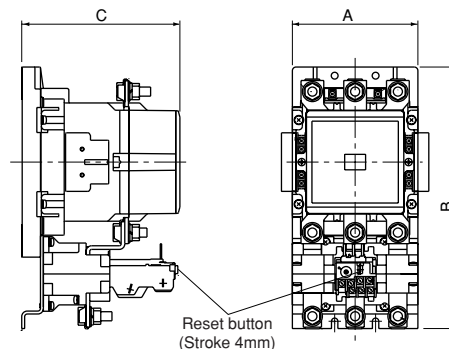

Note: SW-N10/2L, N11/2L, N12/2L and N14/2L,  
SW-N10/3L, N11/3L, N12/3L and N14/3L,  
N11/3H, N12/3H and N14/3H, respectively.

Type	2-element	3-element	A	B	C	Mass (kg)		
				2-element	3-element	2-element	3-element	
SW-N2S/2L	SW-N2S/3L		138	219	219	111	1.54	1.66
SW-N3/2L	SW-N3/3L		138(149)*	219(202)*	219(224)*	111	1.54	1.64
SW-N4/2L	SW-N4/3L		138(149)*	230(214)*	230(236)*	117	2.26	2.54
SW-N5/2L	SW-N5/3L		149	214	236	132	2.66	2.94
SW-N6/2L	SW-N6/3L		165	270	270	138	3.62	3.93
SW-N7/2L	SW-N7/3L		165	281	281	140	3.92	4.23
SW-N8/2L	SW-N8/3L		138	287	287	174	6.8	6.8

\*( ) = In case of ampere setting range 45 to 65A

Dimensions for reference only. Confirm before construction begins.

**Motor starters with quick operating thermal overload relay**

Up to 55kW 440 Volts 3-phase

**Description**

This motor starter is fitted with a quick operating type thermal overload relay which makes suitable for controlling submersible motor pumps and compressors. These motor windings are cooled by using liquid or other media.

Thus their overload capacity will be less than standard type motor. This also means that these motors cannot be protected by standard type overload relays since their operation would be rather slow. The starters are available in types ranging from SW-03/3Q to SW-N5/3Q. All thermal overload relays have 3-heater elements.

**Features**

- Thermal overload relays are designed to have similar starting characteristics to those of the motors. These relays will operate quicker than the standard type in the face of a locked rotor current. (Refer to the graph.)
- Compact with external dimensions similar to the standard type.
- The ampere setting dial of the overload relays is calibrated to an RC scale (Rated current). All that is necessary is to set a value equal to the full load current of the motor.

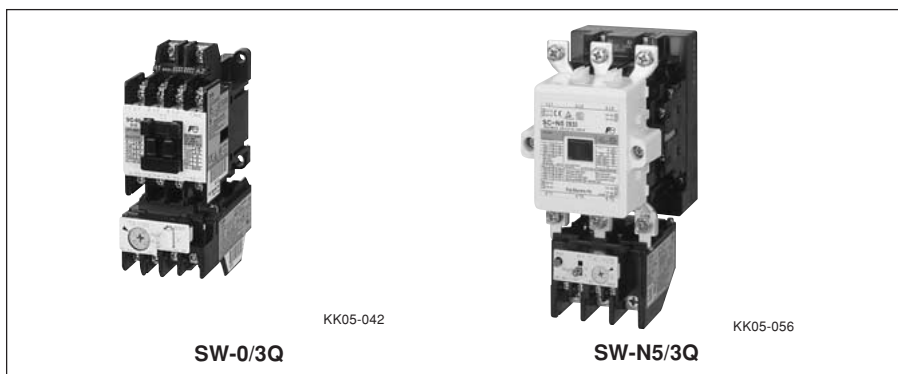

**Operating characteristics**

For explanation only

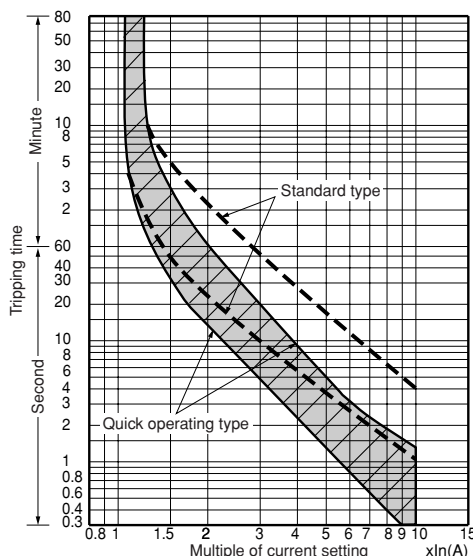

**Ordering information**

Specify the following:

1. Ordering code
2. Overload relay setting range code
3. Operating coil voltage code
4. Auxiliary contact arrangement

**Performance data:**

Same as standard types  
See page 01/30.  
Conforming to Class AC-3, IEC60947-4-1.

**Ratings of coil and auxiliary contact:**

See pages 01/28, 30 and 31.

**Dimensions and wiring diagrams:**

Same as standard types  
See page 01/37, 38 and 39.

**Thermal overload relay:**

See page 01/97.

**Ratings**

Type	Ordering code	Max. motor capacity (kW)		Rated operational current (A)		Auxiliary contact		Combined thermal overload relay	
		200V 240V	380V 440V	200V 240V	380V 440V	NO	NC	Type	Ordering code
SW-03/3Q	SC11AAS-■10T□	2.5	4	11	9	1	— *1	TR-0NQ	TR13SW-□
SW-0/3Q	SC13AAS-■10T□	3.5	5.5	13	12	1	— *1	TR-0NQ	TR13SW-□
SW-05/3Q	SC14AAS-■11T□	3.5	5.5	13	12	1	1 *2	TR-0NQ	TR13SW-□
SW-4-0/3Q	SC18AAS-■10T□	4.5	7.5	18	16	1	— *1	TR-5-1NQ	TR20SW-□
SW-4-1/3Q	SC19AAS-■10T□	4.5	7.5	18	16	1	— *1	TR-5-1NQ	TR20SW-□
SW-5-1/3Q	SC20AAS-■11T□	4.5	7.5	18	16	1	1 *3	TR-5-1NQ	TR20SW-□
SW-5-1/3Q	SC20AAS-■22T□	4.5	7.5	18	16	2	2	TR-5-1NQ	TR20SW-□
SW-N1/3Q	SC25BAAS-■22T□	7.5	15	32	32	2	2	TR-N2Q	TR35BSW-□
SW-N2/3Q	SC35BAAS-■22T□	11	18.5	40	40	2	2	TR-N2Q	TR35BSW-□
SW-N2S/3Q	SC50BAAS-■22T□	15	22	50	50	2	2	TR-N3Q	TR65BSW-□
SW-N3/3Q	SC65BAAS-■22T□	18.5	30	65	65	2	2	TR-N3Q	TR65BSW-□
SW-N4/3Q	SC80BAAS-■22T□	22	40	80	80	2	2	TR-N5Q	TR80BSW-□
SW-N5/3Q	SC93BAAS-■22T□	30	55	105	105	2	2	TR-N5Q	TR1CBSW-□

Notes: \*1 Auxiliary contact 1NC is also available on request.  
\*2 Auxiliary contact 2NO or 2NC is also available on request.  
\*3 Auxiliary contact 2NO, 2NC or 2NO+2NC is also available on request.  
Enter the coil voltage code in the ■ mark.  
Enter the thermal overload relay ampere setting range code in the □ mark.

# Magnetic Motor Starters

## SW series

### With phase-loss protective device

#### Motor starters with phase-loss protective device

Up to 315 kW 440 Volts 3-phase

##### ■ Description

These starters are provided with a FUJI TK type thermal overload relay. This has an phase-loss protection function as well as the ordinary overload protection.

These devices prevent damage due to single-phasing such as fuse melting, cable troubles or loosening through excessive vibration.

They are highly suitable for such applications as cooling fans or circulating pumps for power transformers.

The switches use FUJI SC series contactors which have a life expectancy of over 1 million operations and which makes them suitable for motor controls for industrial use.

Size range from 03 to N14 with capacities from 2.5kW to 180kW 220 Volts AC. Starters are available in both open- and enclosed-type versions.

Reversing motor starters with TK relays are also available.

##### ■ Ordering information

Specify the following:

1. Ordering code
2. Overload relay setting range code
3. Operating coil voltage code
4. Auxiliary contact arrangement

##### ■ Performance data:

Same as standard types.

[See page 01/30.](#)

##### ■ Ratings of coil and auxiliary contacts:

[See pages 01/28, 30 and 31.](#)

##### ■ Dimensions and wiring diagrams:

[See pages 01/37, 38, 39 and 40.](#)

##### ■ Characteristics of TK relay:

[See page 01/109.](#)

##### ■ Thermal overload relays with phase-loss protection

The TK thermal overload relay perfectly matches the heat characteristics of 3-phase squirrel-cage induction motors. The heater element and phase-loss protective mechanism are built inside the enclosure.

The characteristics of the phase-loss



mechanism co-ordinate with the temperature rise curve of the stator winding at the time of phase-loss. When an phase-loss is produced during the full load operation of a 3-phase motor a current larger than the full load current will flow and operate the thermal overload relay.

Under this load condition the standard type OL relay can provide adequate protection. If the load is approx. 60% of the full load current the motor will continue a single phase running and the line current will become almost equal to the full load current.

However, since it will not reach the minimum operating point of OL relay the starter will not be tripped. In the case of a delta winding motor a phase current of approx. 115% of the line full load current will flow in windings. This overcurrent results in a temperature rise in the motor windings and damage due to overheating can be expected.

FUJI TK thermal overload relays are provided with ADL mechanism which can correctly detect phase-loss under such medium load conditions. This sophisticated detecting mechanism can take corrective action quicker in the case of overload running.

The ADL mechanism operates on a dependable and simple level design. It works as follows:—

The heater, in phase-loss, will be cool since no load current flows, while heater of other phases will heat up since a large current flows.

The difference in temperature between the cold and hot heater elements causes the shift lever to operate the Trip/Alarm contact.

The operating current range is 105%–120% of the rated current set on the dial.

#### Reversing motor starter with phase-loss protective device

##### ■ Description

This reversing motor starter uses two contactors and TK type thermal overload relay. The TK relay is provided with a heater element and a built-in mechanism for phase-loss protection use, which match with the thermal characteristics of 3-phase squirrel-cage rotor motor. This eliminates the possibility of damage in the case of the motor overheating.

The TK relay also features manual tripping, a trip-free mechanism, MANUAL/AUTO selector lever, wide range dial ampere adjustment, ambient temperature compensator and 1NO•1NC trip/alarm contact, etc. Starters can be supplied with either open type or provided with enclosures. The general purpose enclosure is made of pressed steel and is not provided with a pushbutton.

■ Types and ratings/Non-reversing

Max. motor capacity (kW)		Operational current (A)		Auxiliary contact	Open Type	Ordering code	Enclosed Type	Ordering code	Combined thermal overload relay
200V	380V	200V	380V	Standard					
240V	440V	240V	440V						
2.5	4	11	9	1NO *1	<b>SW-03/2E</b>	SC11AAE-■10T□	<b>SW-03C/2E</b>	SC11CAE-■10T□	TK-0N
3.5	5.5	13	12	1NO *1	<b>SW-0/2E</b>	SC13AAE-■10T□	<b>SW-0C/2E</b>	SC13CAE-■10T□	TK-0N
3.5	5.5	13	12	1NO+1NC *2	<b>SW-05/2E</b>	SC14AAE-■11T□	<b>SW-05C/2E</b>	SC14CAE-■11T□	TK-0N
4.5	7.5	18	16	1NO *1	<b>SW-4-0/2E</b>	SC18AAE-■10T□	<b>SW-4-0C/2E</b>	SC18CAE-■10T□	TK-5-1N
5.5	11	22	22	1NO *1	<b>SW-4-1/2E</b>	SC19AAE-■10T□	<b>SW-4-1C/2E</b>	SC19CAE-■10T□	TK-5-1N
5.5	11	22	22	1NO+1NC *3	<b>SW-5-1/2E</b>	SC20AAE-■11T□	<b>SW-5-1C/2E</b>	SC20CAE-■11T□	TK-5-1N
7.5	15	32	32	2NO+2NC *4	<b>SW-N1/2E</b>	SC25BAAE-■22T□	<b>SW-N1C/2E</b>	SC25CAE-■22T□	TK-N2
11	18.5	40	40	2NO+2NC *4	<b>SW-N2/2E</b>	SC35BAAE-■22T□	<b>SW-N2C/2E</b>	SC35CAE-■22T□	TK-N2
15	22	50	50	2NO+2NC *4	<b>SW-N2S/2E</b>	SC50BAAE-■22T□	<b>SW-N2SC/2E</b>	SC50CAE-■22T□	TK-N3
18.5	30	65	65	2NO+2NC *4	<b>SW-N3/2E</b>	SC65BAAE-■22T□	<b>SW-N3C/2E</b>	SC65CAE-■22T□	TK-N3
22	40	80	80	2NO+2NC *4	<b>SW-N4/2E</b>	SC80BAAE-■22T□	<b>SW-N4C/2E</b>	SC80CAE-■22T□	TK-N5
30	55	105	105	2NO+2NC *4	<b>SW-N5/2E</b>	SC93BAAE-■22T□	<b>SW-N5C/2E</b>	SC93CAE-■22T□	TK-N5
37	60	125	125	2NO+2NC *4	<b>SW-N6/2E</b>	SC1CBAAE-■22T□	<b>SW-N6C/2E</b>	SC1CCAЕ-■22T□	TK-N6
45	75	150	150	2NO+2NC *4	<b>SW-N7/2E</b>	SC1FBAAE-■22T□	<b>SW-N7C/2E</b>	SC1FCAE-■22T□	TK-N7
55	90	180	180	2NO+2NC *4	<b>SW-N8/2E</b>	SC1JBAAE-■22T□	<b>SW-N8C/2E</b>	SC1JCAE-■22T□	TK-N8
65	110	220	220	2NO+2NC *4	<b>SW-N10/2E</b>	SC2CBAAE-■22T□	<b>SW-N10C/2E</b>	SC2CCAЕ-■22T□	TK-N10
90	160	300	300	2NO+2NC *4	<b>SW-N11/2E</b>	SC3ABAAE-■22T□	<b>SW-N11C/2E</b>	SC3ACAE-■22T□	TK-N11
120	220	400	400	2NO+2NC *4	<b>SW-N12/2E</b>	SC4ABAAE-■22T□	<b>SW-N12C/2E</b>	SC4ACAE-■22T□	TK-N12
180	315	600	600	2NO+2NC *4	<b>SW-N14/2E</b>	SC6ABAAE-■22T□	<b>SW-N14C/2E</b>	SC6ACAE-■22T□	TK-N14

Notes: Enter the coil voltage code in the ■ mark.  
Enter the thermal overload relay ampere setting range code in the □ mark.  
\*1 Auxiliary contact 1NC is available on request.  
\*2 Auxiliary contact 2NO or 2NC is available on request.  
\*3 Auxiliary contact 2NO, 2NC or 2NO+2NC is available on request. However, 2NO+2NC is not available for enclosed types.  
\*4 Auxiliary contact 4NO+4NC is available on request for frame sizes N1 and above.

■ Types and ratings/Reversing

Max. motor capacity (kW)		Operational current (A)		Auxiliary contact	Open Type	Ordering code	Enclosed Type	Ordering code	Combined thermal overload relay
200V	380V	200V	380V	Standard					
240V	440V	240V	440V						
2.5	4	11	9	1NC × 2 *1	<b>SW-03RM/2E</b>	SC11RAE-■01T□	<b>SW-03RMC/2E</b>	SC11MAE-■01T□	TK-0N
3.5	5.5	13	12	1NC × 2 *1	<b>SW-0RM/2E</b>	SC13RAE-■01T□	<b>SW-0RMC/2E</b>	SC13MAE-■01T□	TK-0N
3.5	5.5	13	12	(1NO+1NC) × 2 *2	<b>SW-05RM/2E</b>	SC14RAE-■11T□	<b>SW-05RMC/2E</b>	SC14MAE-■11T□	TK-0N
4.5	7.5	18	16	1NC × 2 *1	<b>SW-4-0RM/2E</b>	SC18RAE-■01T□	<b>SW-4-0RMC/2E</b>	SC18MAE-■01T□	TK-5-1N
5.5	11	22	22	1NC × 2 *1	<b>SW-4-1RM/2E</b>	SC19RAE-■01T□	<b>SW-4-1RMC/2E</b>	SC19MAE-■01T□	TK-5-1N
5.5	11	22	22	(1NO+1NC) × 2 *3	<b>SW-5-1RM/2E</b>	SC20RAE-■11T□	<b>SW-5-1RMC/2E</b>	SC20MAE-■11T□	TK-5-1N
7.5	15	32	32	(2NO+2NC) × 2 *4	<b>SW-N1RM/2E</b>	SC25BRAE-■22T□	<b>SW-N1RMC/2E</b>	SC25BMAE-■22T□	TK-N2
11	18.5	40	40	(2NO+2NC) × 2 *4	<b>SW-N2RM/2E</b>	SC35BRAE-■22T□	<b>SW-N2RMC/2E</b>	SC35BMAE-■22T□	TK-N2
15	22	50	50	(2NO+2NC) × 2 *4	<b>SW-N2SRM/2E</b>	SC50BRAE-■22T□	<b>SW-N2SRMC/2E</b>	SC50BMAE-■22T□	TK-N3
18.5	30	65	65	(2NO+2NC) × 2 *4	<b>SW-N3M/2E</b>	SC65BRAE-■22T□	<b>SW-N3RMC/2E</b>	SC65BMAE-■22T□	TK-N3
22	40	80	80	(2NO+2NC) × 2 *4	<b>SW-N4RM/2E</b>	SC80BRAE-■22T□	<b>SW-N4RMC/2E</b>	SC80BMAE-■22T□	TK-N5
30	55	105	105	(2NO+2NC) × 2 *4	<b>SW-N5RM/2E</b>	SC93BRAE-■22T□	<b>SW-N5RMC/2E</b>	SC93BMAE-■22T□	TK-N5
37	60	125	125	(2NO+2NC) × 2 *4	<b>SW-N6RM/2E</b>	SC1CBRAE-■22T□	<b>SW-N6RMC/2E</b>	SC1CBMAE-■22T□	TK-N6
45	75	150	150	(2NO+2NC) × 2 *4	<b>SW-N7RM/2E</b>	SC1FBRAE-■22T□	<b>SW-N7RMC/2E</b>	SC1FBMAE-■22T□	TK-N7
55	90	180	180	(2NO+2NC) × 2 *4	<b>SW-N8RM/2E</b>	SC1JBRAE-■22T□	<b>SW-N8RMC/2E</b>	SC1JBMAE-■22T□	TK-N8
65	110	220	220	(2NO+2NC) × 2 *4	<b>SW-N10RM/2E</b>	SC2CBRAE-■22T□	<b>SW-N10RMC/2E</b>	SC2CBMAE-■22T□	TK-N10
90	160	300	300	(2NO+2NC) × 2 *4	<b>SW-N11RM/2E</b>	SC3ABRAE-■22T□	<b>SW-N11RMC/2E</b>	SC3ABMAE-■22T□	TK-N11
120	220	400	400	(2NO+2NC) × 2 *4	<b>SW-N12RM/2E</b>	SC4ABRAE-■22T□	<b>SW-N12RMC/2E</b>	SC4ABMAE-■22T□	TK-N12
180	315	600	600	(2NO+2NC) × 2 *4	<b>SW-N14RM/2E</b>	SC6ABRAE-■22T□	<b>SW-N14RMC/2E</b>	SC6ABMAE-■22T□	TK-N14

Notes: Enter the coil voltage code in the ■ mark.  
Enter the thermal overload relay ampere setting range code in the □ mark.  
\*1 Auxiliary contact 1NO×2 is available on request. However, these contactors are not electrically interlocked. Be sure to arrange electrical interlock circuit externally to avoid short-circuit accidents.  
\*2 Auxiliary contact 2NC×2 is available on request.  
\*3 Auxiliary contact 2NC×2 or (2NO+2NC)×2 is available on request. However, (2NO+2NC)×2 is not available for enclosed types.  
\*4 Auxiliary contact (3NO+3NC)×2 is available on request.

# Magnetic Motor Starters

## SW series

### With phase-loss and phase-sequence protective device

#### Motor starters with phase-loss and phase-sequence relays

Up to 315kW 440 Volts 3-phase

#### ■ Description

These starters are fitted with TK type thermal overload relay and phase-sequence relay. The phase-sequence relay only permits engagement of the starter when the phase rotation is confirmed to be correct.

These switches are mainly used for construction site machinery, window shutters, machine tools, compressors, freezers, conveyors, underwater pumps, car washing machines, blowers and similar applications. They give excellent protection against damage and overheating resulting from phase-loss operation.

#### ■ Ordering information

Specify the following:

- Ordering code  
2E type motor starter and phase sequence relay QE-20N.
- Overload relay setting range code
- Operating coil voltage code

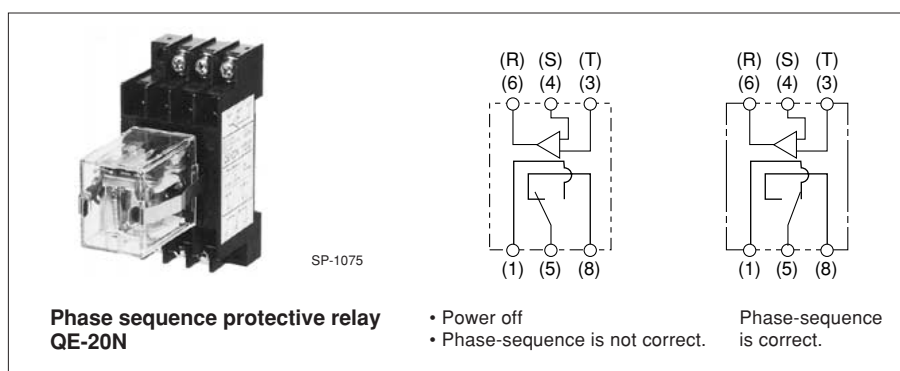
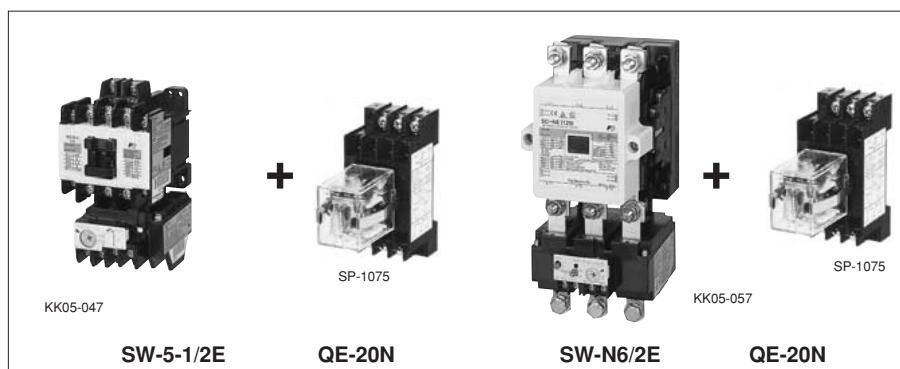

#### ■ Types and ratings

Max. motor capacity (kW)		Operational current (A)		Auxiliary contact	Starter with 2E type thermal overload relay		Phase-sequence protective relay	
200V	380V	200V	380V	Standard	Type	Ordering code	Type	Ordering code
240V	440V	240V	440V					
2.5	4	11	9	1NO *1	SW-03/2E	SC11AAE-■10T□	200-220V:	
3.5	5.5	13	12	1NO *1	SW-0/2E	SC13AAE-■10T□	QE-20N	TQ1CPN
3.5	5.5	13	12	1NO + 1NC *2	SW-05/2E	SC14AAE-■11T□		
4.5	7.5	18	16	1NO *1	SW-4-0/2E	SC18AAE-■10T□		
5.5	11	22	22	1NO *1	SW-4-1/2E	SC19AAE-■10T□	380-415V:	
5.5	11	22	22	1NO + 1NC *3	SW-5-1/2E	SC20AAE-■11T□	QE-40N	TQ2CPN
5.5	11	22	22	2NO + 2NC	SW-5-1/2E	SC20AAE-■22T□		
7.5	15	32	32	2NO + 2NC *4	SW-N1/2E	SC25BAAE-■22T□		
11	18.5	40	40	2NO + 2NC *4	SW-N2/2E	SC35BAAE-■22T□		
15	22	50	50	2NO + 2NC *4	SW-N2S/2E	SC50BAAE-■22T□		
18.5	30	65	65	2NO + 2NC *4	SW-N3/2E	SC65BAAE-■22T□		
22	40	80	80	2NO + 2NC *4	SW-N4/2E	SC80BAAE-■22T□		
30	55	105	105	2NO + 2NC *4	SW-N5/2E	SC93BAAE-■22T□		
37	60	125	125	2NO + 2NC *4	SW-N6/2E	SC1CBAAE-■22T□		
45	75	150	150	2NO + 2NC *4	SW-N7/2E	SC1FBAAE-■22T□		
55	90	180	180	2NO + 2NC *4	SW-N8/2E	SC1JBAAE-■22T□		
65	110	220	220	2NO + 2NC *4	SW-N10/2E	SC2CBAAE-■22T□		
90	160	300	300	2NO + 2NC *4	SW-N11/2E	SC3ABAAE-■22T□		
120	220	400	400	2NO + 2NC *4	SW-N12/2E	SC4ABAAE-■22T□		
180	315	600	600	2NO + 2NC *4	SW-N14/2E	SC6ABAAE-■22T□		

Notes: Enter the coil voltage code in the ■ mark.

Enter the thermal overload relay ampere setting range code in the □ mark.

\*1 Auxiliary contact 1NC is available on request.

\*2 Auxiliary contact 2NO or 2NC is available on request.

\*3 Auxiliary contact 2NO or 2NC is available on request.

\*4 Auxiliary contact 4NO+4NC is available on request for frame sizes N1 and above.

#### ■ Performance data:

Same as standard types.

[See page 01/30.](#)

#### ■ Ratings of coil and auxiliary contacts:

[See pages 01/28, 30 and 31.](#)

#### ■ TK type thermal overload relays:

[See page 01/109.](#)

#### ■ Thermal overload relays with phase-loss and phase-sequence protective relays

Motor starters with 3E relay are fitted with both TK type thermal overload and QE-20N type phase-sequence protective relays.

If the phase rotation of the power supply is not correct the relay will not permit the starter to be switched ON.

These starters provide motors with accurate and consistent protection under overcurrent, phase-loss and reverse-phase conditions.

■ **Method of operation**

The FUJI phase-sequence relay contacts 1–5 will close if the phase rotation of the power source is correct. In case the rotation is incorrect the contacts 1–5 will remain open and the magnetic coil A1–A2 will not be energized.

■ **Dimensions, mm**

● **Starter with phase-loss protection SW-03/2E to 14N/2E (Open)**  
 Same as standard types.  
 See pages 01/37 to 01/40.

■ **Wiring diagrams (example)**

● **QE-20N, 20NL 200–220V**

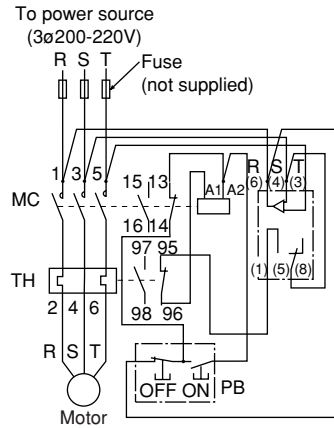

● **QE-40N 380–415V**

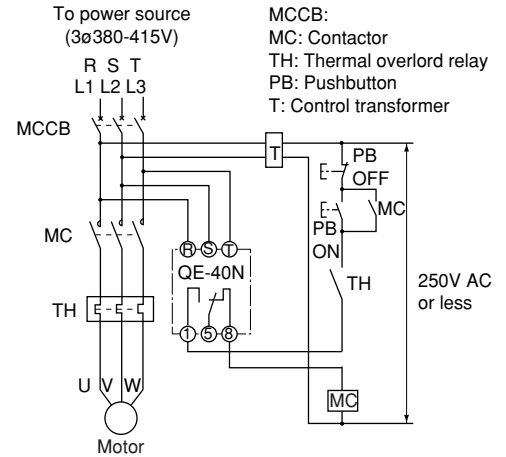

● **Phase-sequence protective relay QE-20N, 20NL**

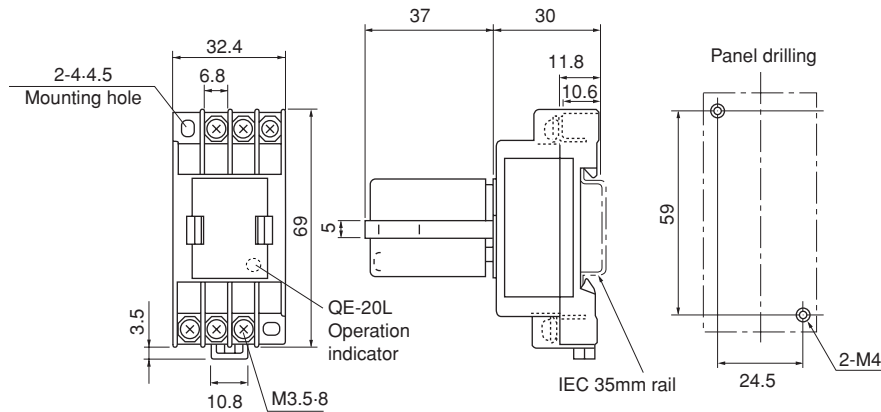

**QE-40N**

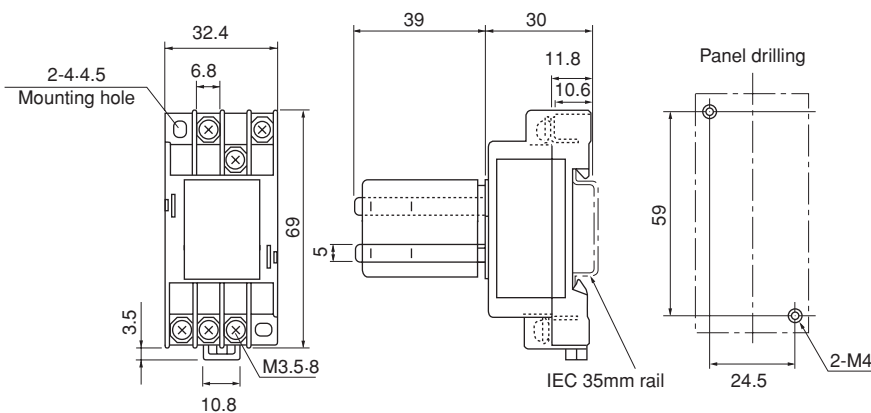

*Dimensions for reference only. Confirm before construction begins.*

# Magnetic Motor Starters

## SW series

### Enclosed with pushbuttons

#### Motor starters with on-off/reset pushbuttons

Up to 110kW 440 Volts

##### ■ Description

It is provided with on-off push-buttons. Its small size makes little demand on space. The enclosure is a general purpose type and is made of pressed steel sheet. (Plastic enclosure for SW-03P to SW-5-1P)  
Compact, space-saving and easily mounted FUJI integral motor starters are highly reliable and efficient products to satisfy your application requirements. They are used with single and 3-phase squirrel-cage induction motors. Essentially consisting of a magnetic contactor and a thermal overload relay these units provide complete motor overload protection with the convenience of an outside reset button mounted on the front of the starter box.

##### ● Contactors

FUJI integral motor starters use the SC series of contactors. All starters incorporate the usual FUJI features. These include free-floating magnetic mechanisms, bounce damping devices, long-life low-maintenance silver alloy contacts and rapid heat-dispersing arc-quenchers. Starter exceed IEC specifications as far as service life is concerned.

Choice of FUJI equipment will ensure you reduced maintenance, inspection and labor costs and uninterrupted dependable service. Available motor capacities are from 4kW to 110kW at 380 Volts.

##### ● Thermal overload relays

Highly efficient heater elements and ambient temperature compensators give motors added protection and more uniform performance. They are fitted with 3-pole heater elements, and resetting is carried out manually with the reset button.

##### ■ Coil ratings:

[See page 01/30.](#)

Same as standard type starters.



##### ■ Performance data:

- Operating cycle: 1,200 cycles per hours
- Life expectancy (operations)
  - Mechanical: 250,000
  - Electrical: 250,000

##### ■ Thermal overload relay:

[See page 01/98.](#)

Same as standard type starters.

##### ■ Ordering information

Specify the following:

1. Ordering code
2. Overload relay setting range code
3. Operating coil voltage code

##### ■ Ratings

Max. motor capacity (kW) Single-phase 110V	3-phase		Auxiliary contact Standard	With on-off/reset pushbutton		With on-off pushbutton		Combined thermal overload relay
	200V	380V 240V 440V		Type	Ordering code	Type	Ordering code	
0.4	2.5	4	1NO	SW-03P/3H	SC11PAN-■10T□□	—	—	TR-0N/3
0.5	3.5	5.5	1NO	SW-0P/3H	SC13PAN-■10T□□	—	—	TR-0N/3
0.5	3.5	5.5	1NO+1NC	SW-05P/3H	SC14PAN-■11T□□	—	—	TR-0N/3
0.6	4.5	7.5	1NO	SW-4-0P/3H	SC18PAN-■10T□□	—	—	TR-5-1N/3
0.8	5.5	11	1NO	SW-4-1P/3H	SC20PAN-■10T□□	—	—	TR-5-1N/3
0.8	5.5	11	1NO+1NC	SW-5-1P/3H	SC20PAN-■11T□□	—	—	TR-5-1N/3
1.2	7.5	15	2NO+2NC	SW-N1PB/3H	SC25BSAN-■22T□□	SW-N1P/3H	SC25BPAN-■22T□□	TR-N2/3
1.7	11	18.5	2NO+2NC	SW-N2PB/3H	SC35BSAN-■22T□□	SW-N2P/3H	SC35BPAN-■22T□□	TR-N2/3
—	15	22	2NO+2NC	SW-N2SPB/3H	SC50BSAN-■22T□□	SW-N2SP/3H	SC50BPAN-■22T□□	TR-N3/3
—	18.5	30	2NO+2NC	SW-N3PB/3H	SC65BSAN-■22T□□	SW-N3P/3H	SC65BPAN-■22T□□	TR-N3/3
—	22	40	2NO+2NC	SW-N4PB/3H	SC80BSAN-■22T□□	—	—	TR-N5/3
—	30	55	2NO+2NC	SW-N5PB/3H	SC93BSAN-■22T□□	—	—	TR-N5/3
—	37	60	2NO+2NC	SW-N6PB/3H	SC1CBSAN-■22T□□	—	—	TR-N6/3
—	55	90	2NO+2NC	SW-N8PB/3H	SC1JBSAN-■22T□□	—	—	TR-N8/3
—	65	110	2NO+2NC	SW-N10PB/3H	SC2CBSAN-■22T□□	—	—	TR-N10/3

Notes: 2-element is available on request.

Enter the coil voltage code in the ■ mark.

Enter the thermal overload relay ampere setting range code in the □ mark.

##### ■ Wiring diagrams

SW-03P/3H, 0P/3H  
SW-4-0P/3H, 4-1P/3H

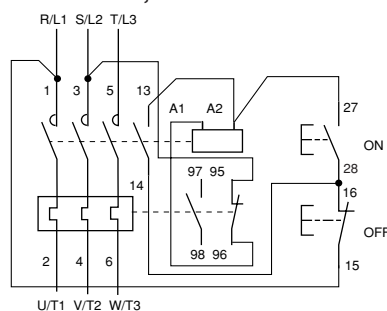

SW-05P/3H, 5-1P/3H

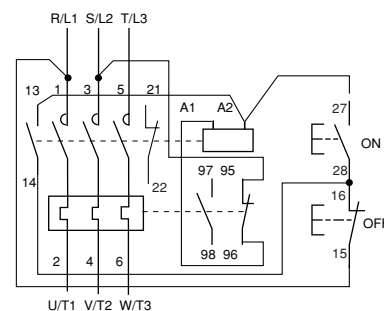

SW-N1PB/3H to N10PB/3H  
SW-N1P/3H to N3P/3H

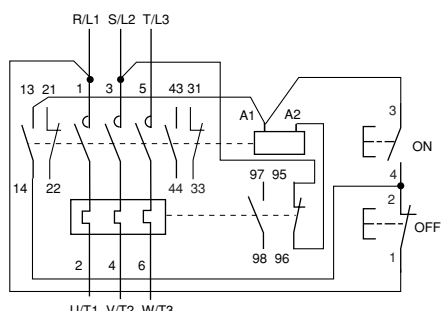



■ Dimensions, mm  
 SW-03P to SW-5-1P

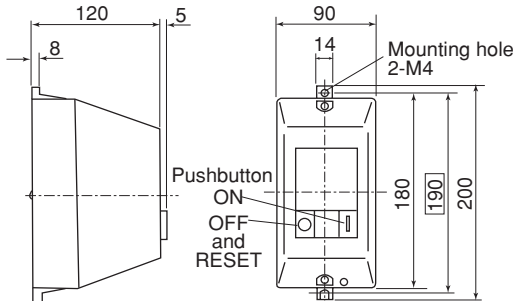

Type	Mass (kg)
SW-03P/3H	0.82
SW-0P/3H	0.82
SW-05P/3H	0.84
SW-4-0P/3H	0.86
SW-4-1P/3H	0.86
SW-5-1P/3H	0.89

Plastic enclosure

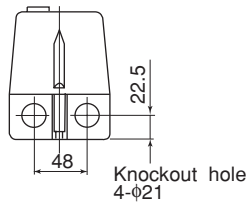

SW-N1PB to SW-N5PB  
 SW-N1P to SW-N3P

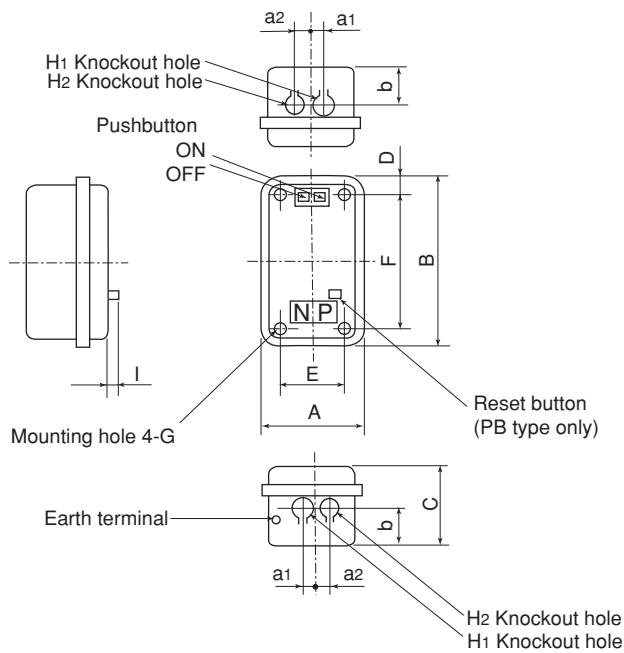

SW-N6PB to SW-N10PB

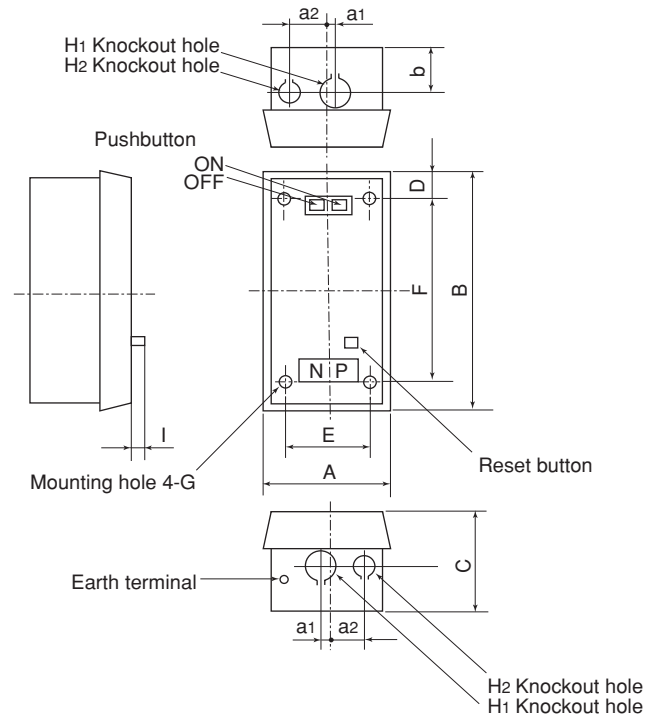

Type		A	B	C	D	E	F	G	H <sub>1</sub>	H <sub>2</sub>	I	a <sub>1</sub>	a <sub>2</sub>	b	Mass (kg)	
															PB type	P type
SW-N1PB/3H	N1P/3H	175	320	145	35	110	250	M6	φ35	φ28	12	15	35	70	2.6	2.5
SW-N2PB/3H	N2P/3H	175	320	145	35	110	250	M6	φ35	φ28	12	15	35	70	2.6	2.5
SW-N2SPB/3H	N2SP/3H	175	320	145	35	110	250	M6	φ35	φ28	12	15	35	70	3.2	3.1
SW-N3PB/3H	N3P/3H	175	320	145	35	110	250	M6	φ35	φ28	12	15	35	70	3.2	3.1
SW-N4PB/3H		200	400	160	37	125	325	M8	φ43	φ28	12	20	40	80	4.6	—
SW-N5PB/3H		200	400	160	37	125	325	M8	φ43	φ28	12	20	40	80	5.0	—
SW-N6PB/3H		225	450	180	50	150	350	M8	φ52	φ28	12	10	70	80	8.6	—
SW-N8PB/3H		335	670	225	85	200	500	M10	φ78	φ28	11	—	100	95	18.2	—
SW-N10PB/3H		335	670	225	85	200	500	M10	φ78	φ28	11	—	100	95	19.3	—

Mass: with 3-thermal element

# Magnetic Motor Starters

## SW series

### Dust-tight/light-corrosion resistance

#### Dust-tight/light-corrosion resistance starters

##### ■ Description

When selecting a motor starter the operating conditions must be carefully considered. Attention must be given to such problems as dust, chemically aggressive atmosphere, water, oil and hazardous materials.

We can supply enclosures that meet the special needs of such industries as the cement and textile industries, where dust and lint can be expected, and the fertilizer, synthetic fiber, oil refining and electrochemical and metal-plating industries where corrosive gases and materials can affect the performance of electrical equipment.

A pressed metal enclosure designed for use in locations where dust, lint, fibers and similar airborne materials are present. The hingeless-type cover is provided with a corrosion-resistant rubber gasket and it is secured by screws. Knockout holes are situated at the top and bottom of the enclosure to accept conduit hubs or glands.

This type is for indoor use.

The outside surface of the enclosure is treated with a special anti-corrosion coating. This type of case is

recommended for cement and fertilizer plants and similar dusty locations. It is also suitable for oil refineries, breweries and metal-plating workshops and coastal areas where aggressive chemical conditions can be expected. This type of enclosure is not suitable for hazardous gas or hazardous dust locations.

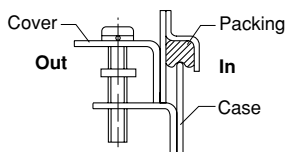

##### ■ Ordering information

Specify the following:

1. Ordering code
2. Overload relay setting range code
3. Operating coil voltage code
4. Method of wiring works and size of conduit pipe
5. Type and density of gas



■ **Types and ratings:** See page 01/33. Same as standard enclosed type.

■ **Performance data:** Same as standard type.

See page 01/30.

■ **Ratings of coil and auxiliary contact:**

See pages 01/28, 30 and 31.

■ **Thermal overload relay:** See page 01/97.

##### ■ Application for special atmosphere

Description	Standard type	Dust-tight/light corrosion res. (lg)
Dust-tight	—	○
Moisture-proof	○	○
Drip-proof	—	—
Splashing-proof	—	○
Rain-proof	—	—
Corrosion-resistant		
Light	○	○
Medium	—	○
Hazardous locations	—	—
Gas-tight	—	—

Note: ○ : Available  
— : Not available

##### ■ Dimensions, mm

###### SW-03LG to SW-5-1LG

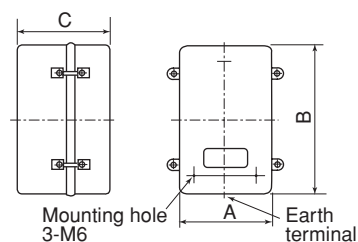

###### SW-N6LG to N10LG

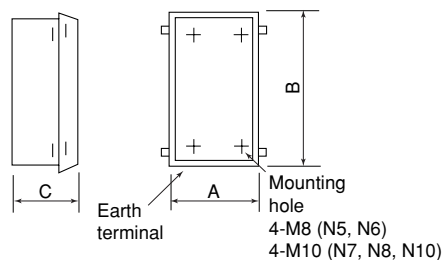

###### SW-N1LG to SW-N5LG

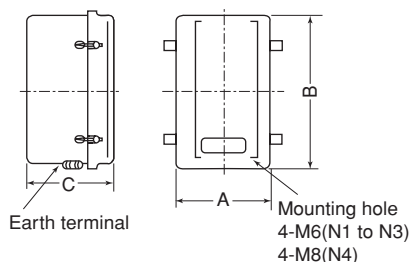

Dimensions for reference only. Confirm before construction begins.

Type	Ordering code	Aux. contact	A	B	C	Mass (kg)
SW-03LG/3H	SC11LAN-■10T□D	1NO	120	195	117	1.4
SW-0LG/3H	SC13LAN-■10T□D	1NO	120	195	117	1.4
SW-05LG/3H	SC14LAN-■11T□D	1NO + 1NC	120	195	117	1.4
SW-4-0LG/3H	SC18LAN-■10T□D	1NO	120	195	117	1.5
SW-4-1LG/3H	SC19LAN-■10T□D	1NO	120	195	117	1.5
SW-5-1LG/3H	SC20LAN-■11T□D	1NO + 1NC	120	195	117	1.5
SW-N1LG/3H	SC25LAN-■22T□D	2NO + 2NC	145	246	135	2.0
SW-N2LG/3H	SC35LAN-■22T□D	2NO + 2NC	145	246	135	2.0
SW-N2SLG/3H	SC50LAN-■22T□D	2NO + 2NC	175	320	145	3.1
SW-N3LG/3H	SC65LAN-■22T□D	2NO + 2NC	175	320	145	3.1
SW-N4LG/3H	SC80LAN-■22T□D	2NO + 2NC	200	400	160	4.5
SW-N5LG/3H	SC93LAN-■22T□D	2NO + 2NC	200	400	160	4.5
SW-N6LG/3H	SC1CLAN-■22T□D	2NO + 2NC	225	450	180	8.5
SW-N7LG/3H	SC1FLAN-■22T□D	2NO + 2NC	280	588	210	12.3
SW-N8LG/3H	SC1JLAN-■22T□D	2NO + 2NC	335	698	225	18.1
SW-N10LG/3H	SC2CLAN-■22T□D	2NO + 2NC	335	698	225	18.8

■: Coil voltage code    □: Thermal overload relay ampere setting range code

**Resistance load magnetic contactors**

**■ Description**

These single pole contactors are for exclusively resistive load use. They are provided with large and sturdy parallel plate terminals attached to the 3-pole standard contactors to make them suitable for large current ratings. Typical applications are for industrial heating controls, PVA processing, solution vats, electric resistance furnaces, heat treatment facilities, drying kilns, farming, marine farming, lighting and similar purposes.

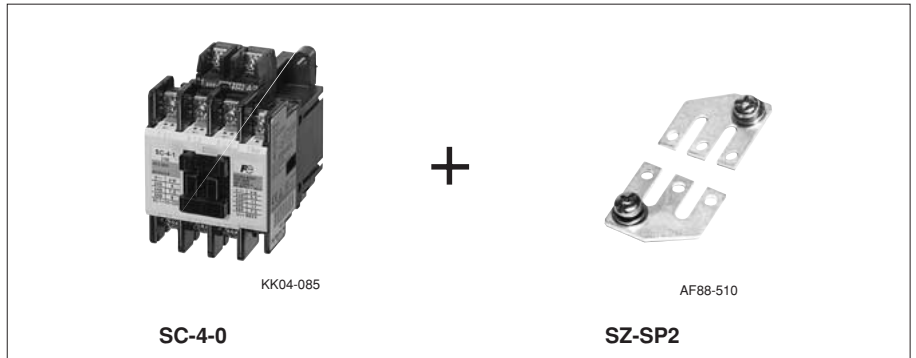

**■ Ordering information**

Specify the following:

1. Ordering code
2. Operating coil voltage code
3. State clearly "with parallel plate terminals for attaching to contactor".
4. Application and rated load current

**■ Types and ratings**

Operational current (A) 110V/220V	Auxiliary contact		Making and breaking current	Operating cycles per hour	Life expectancy (operations)		Contactor Type		3-pole parallel terminal plate	
	NO	NC			Electrical	Mechanical	Type	Ordering code	Type	Ordering code
25	1	—	1.5 × Ie	150	500,000	10 millions	SC-03	SC11AA-■10	SZ-SP1	SZ1SP1
30	1	—	1.5 × Ie	150	500,000	10 millions	SC-0	SC13AA-■10	SZ-SP1	SZ1SP1
30	1	1	1.5 × Ie	150	500,000	10 millions	SC-05	SC14AA-■11	SZ-SP1	SZ1SP1
40	1	—	1.5 × Ie	150	500,000	10 millions	SC-4-0	SC18AA-■10	SZ-SP2	SZ1SP2
50	1	—	1.5 × Ie	150	500,000	10 millions	SC-4-1	SC19AA-■10	SZ-SP2	SZ1SP2
50	1	1	1.5 × Ie	150	500,000	10 millions	SC-5-1	SC20AA-■11	SZ-SP2	SZ1SP2
50	2	2	1.5 × Ie	150	500,000	10 millions	SC-5-1	SC20AA-■22	SZ-SP2	SZ1SP2
100	2	2	1.5 × Ie	150	500,000	5 millions	SC-N1	SC25BAA-■22	SZ-SP3	SZ2SP3
125	2	2	1.5 × Ie	150	500,000	5 millions	SC-N2	SC35BAA-■22	SZ-SP3	SZ2SP3
200	2	2	1.5 × Ie	150	250,000	5 millions	SC-N2S	SC50BAA-■22	SZ-SP4	SZ2SP4
250	2	2	1.5 × Ie	150	250,000	5 millions	SC-N3	SC65BAA-■22	SZ-SP4	SZ2SP4
315	2	2	1.5 × Ie	150	250,000	5 millions	SC-N4	SC80BAA-■22	SZ-SP5	SZ2SP5
400	2	2	1.5 × Ie	150	250,000	5 millions	SC-N5	SC93BAA-■22	SZ-SP5	SZ2SP5
400	2	2	1.5 × Ie	150	250,000	5 millions	SC-N6	SC1CBAA-■22	SZ-SP6	SZ2SP6
500	2	2	1.5 × Ie	150	250,000	5 millions	SC-N7	SC1FBAA-■22	SZ-SP7	SZ2SP7
630	2	2	1.5 × Ie	150	250,000	5 millions	SC-N8	SC1JBAA-■22	SZ-SP8	SZ2SP8
710	2	2	1.5 × Ie	150	250,000	5 millions	SC-N10	SC2ABAA-■22	SZ-SP8	SZ2SP8
900	2	2	1.5 × Ie	150	250,000	5 millions	SC-N11	SC3ABAA-■22	SZ-SP9	SZ2SP9
1000	2	2	1.5 × Ie	150	250,000	5 millions	SC-N12	SC4ABAA-■22	SZ-SP9	SZ2SP9
1600	2	2	1.5 × Ie	150	250,000	5 millions	SC-N14	SC6ABAA-■22	SZ-SP10	SZ2SP10
2100	2	2	1.5 × Ie	150	100,000	2,500,000	SC-N16	SC8ABAA-■22	SZ-SP11	SZ2SP11

Notes: 1. ■: Coil voltage code, see page 01/27  
 2. Ie: Rated operational current. Conforming to Class AC-1, IEC60947-4-1.

**■ Dimensions, mm**

**SC-03 + SZ-SP1 to SC-5-1 + SZ-SP2**

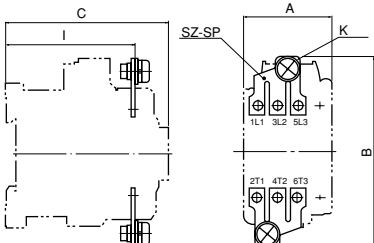

**SC-N1+SZ-SP3 to SC-N16+SZ-SP11**

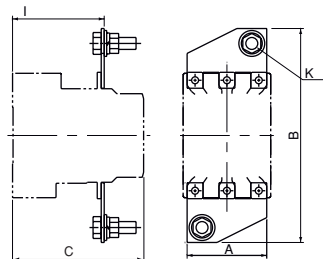

Type	A	B	C	I	K	Mass (g) *
SC-03+SZ-SP1	43	90	80	63	M6	25
SC-0+SZ-SP1	43	90	80	63	M6	25
SC-05+SZ-SP1	53	90	80	63	M6	25
SC-4-0+SZ-SP2	53	100	81	63	M6	35
SC-4-1+SZ-SP2	53	100	81	63	M6	35
SC-5-1+SZ-SP2	64	100	81	63	M6	35
	64	100	109	63	M6	35
SC-N1, N2+SZ-SP3	74	132	96	64	M8	110
SC-N2S, N3+SZ-SP4	88	174	111	75.5	M10	200
SC-N4+SZ-SP4	88	215	117	77	M12	320

Type	A	B	C	I	K	Mass (g) *
SC-N5+SZ-SP4	88	215	132	92	M12	320
SC-N6+SZ-SP6	100	300	138	98	M12×2	760
SC-N7+SZ-SP7	115	312	140	98	M12×2	800
SC-N8, N10+SZ-SP8	138	371	174	120	M12×2	1300
SC-N11, N12+SZ-SP9	153	420	195	135	M12×4	3000
SC-N14+SZ-SP10	290	525	328	246	M12×4	4400
SC-N16+SZ-SP11	290	525	328	246	M12×4	5900

\*Mass: 3-pole parallel terminal plate only

# Magnetic Contactors

## SC series

### With single button auxiliary contact

#### Magnetic contactors with single button auxiliary contact

##### ■ Description

The SC-03H to N12H contactors are improved versions of the standard SC-03 to SC-N12 contactors. The improvement consists of changing the auxiliary contact from a bifurcated to a single button type contact. This change increases the auxiliary contact rating. The specifications, including the main contact rating and the expected electrical service life, are similar to that of the SC-03 to N12 types. The options for the SC series, such as the coil surge suppressor and mechanical interlock can also be used.

##### ■ Type number nomenclature

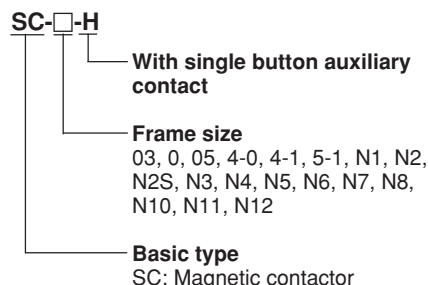

##### ■ Performance data

Same as standard types

##### ■ Ordering information

Specify the following:

1. Ordering code
2. Operating coil voltage code
3. Auxiliary contact arrangement code.



##### ■ Coil voltage

Same as standard type, [See page 01/30](#)

#### ■ Ratings (Conforming to AC-3, IEC 60947-4-1)

Type	Ordering code	Max. motor capacity (kW)				Rated operational current (A)				Rated thermal current (A)	Auxiliary contact
		3-phase				3-phase					
		200V	380V	500V	600V	200V	380V	500V	600V		Standard
		240V	440V	550V	660V	240V	440V	550V	660V		
SC-03H	SC11AH-■10	2.5	4	4	4	11	9	7	5	20	1NO
SC-0H	SC13AH-■10	3.5	5.5	5.5	5.5	13	12	9	7	20	1NO
SC-05H	SC14AH-■11	3.5	5.5	5.5	5.5	13	12	9	7	20	1NO+1NC
SC-4-0H	SC18AH-■10	4.5	7.5	7.5	7.5	18	16	13	9	25	1NO
SC-4-1H	SC19AH-■10	5.5	11	11	7.5	22	22	17	9	32	1NO
SC-5-1H	SC20AH-■11	5.5	11	11	7.5	22	22	17	9	32	1NO+1NC
SC-5-1H	SC20AH-■22	5.5	11	11	7.5	22	22	17	9	32	2NO+2NC *
SC-N1H	SC25BAH-■11	7.5	15	15	11	32	32	24	15	50	2NO+2NC
SC-N2H	SC35BAH-■11	11	18.5	18.5	15	40	40	29	19	60	2NO+2NC
SC-N2SH	SC50BAH-■11	15	22	25	22	50	50	38	26	80	2NO+2NC
SC-N3H	SC65BAH-■11	18.5	30	37	30	65	65	60	38	100	2NO+2NC
SC-N4H	SC80BAH-■11	22	40	37	37	80	80	60	44	135	2NO+2NC
SC-N5H	SC93BAH-■11	30	55	55	55	105	105	85	64	150	2NO+2NC
SC-N6H	SC1CBAH-■11	37	60	60	60	125	125	90	72	150	2NO+2NC
SC-N7H	SC1FBAH-■11	45	75	75	90	150	150	120	103	200	2NO+2NC
SC-N8H	SC1JBAH-■11	55	90	130	132	180	180	180	150	260	2NO+2NC
SC-N10H	SC2CBAH-■11	65	110	132	132	220	220	200	150	260	2NO+2NC
SC-N11H	SC3ABAH-■11	90	160	160	200	300	300	230	230	350	2NO+2NC
SC-N12H	SC4ABAH-■22	120	220	250	300	400	400	360	360	360	2NO+2NC

Notes: Enter the coil voltage code in the ■ mark

\* With auxiliary contact block SZ-A11 (1NO+1NC)

#### ■ Auxiliary contact ratings (Conforming to IEC 60947-5-1)

Type	Continuous current (A)	Make/break current (AC, A)	Rated operational current (A)			DC Voltage (V)	DC-13 (Ind. load)	DC-12 (Res. load)
			AC Voltage (V)	AC-15 (Ind. load)	AC-12 (Res. load)			
SC-03H to SC5-1H	10	60	100–120 200–240	6	10	24 48	5 1.5	10 5
			380–440 500–550	4	10	110 220	0.7 0.27	4 1
SC-N1H to SC-N12H	10	60	100–120 200–240	6	10	24 48	10 3	10 5
			380–440	4	10	110	1.5	2.5
			500–600	2.5	10	220	0.5	1

**Contactors and starters with quick connection terminals**

■ **Feature**

- Easy wiring  
Wiring time is at least 50% shorter than previous type.
- Safety  
The finger protection feature protects the charging current part during maintenance and check (complying with EN60947-4-1, and IEC60947-4-1)
- International use  
The product and terminal structure comply with international safety standards.  
It complies with VGB4, DIN57106, VDE0106, and VDE Teil 100 which are recommendation for preventing the exposure of charging current part.

**Quick connection terminal**

- When one crimp terminal is used

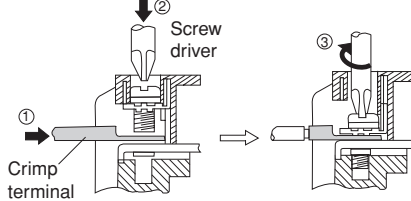

- When two crimp terminals are used

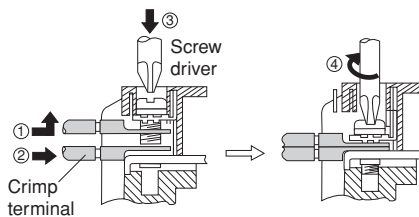

■ **Types and rating**

Max. motor capacity (kW)		Rated operational current (A)				Rated thermal current (A)	Auxiliary contact arrangement	Contactor Type	Starter 3-element Type
3-phase AC-3 200V 240V 2.5	380V 440V 4	3-phase motor AC-3 200V 380V 240V 440V 11 9		Resistive load AC-1 200V 380V 240V 440V 20 20					
3.5	5.5	13	12	20	20	20	1NO 1NC	SC-03Y10 SC-03Y01	SW-03Y/3H10 SW-03Y/3H01
3.5	5.5	13	12	20	20	20	2NO 1NO,1NC 2NC	SC-05Y20 SC-05Y11 SC-05Y02	SW-05Y/3H20 SW-05Y/3H11 SW-05Y/3H02
5.5	11	22	22	32	32	32	2NO 1NO,1NC 2NC	SC-5-1Y20 SC-5-1Y11 SC-5-1Y02	SW-5-1Y/3H20 SW-5-1Y/3H11 SW-5-1Y/3H02

■ **Ordering information**

- Specify the following:
1. Type number
  2. Coil voltage (Contactor only)
  3. Main circuit voltage (Starter only)
  4. Thermal overload setting range code (Starter only)
- [See page 01/27.](#)

■ **Dimensions and panel drilling**

Same as the standard types

■ **Mass**

Same as the standard types

■ **Optional unit**

**Auxilliary contact blocks with quick connection terminals**

Mounting	Thermal current (A)	Contact arrangement	Type
Front mounting	10	4NO 3NO+1NC 2NO+2NC	SZ-A40Y SZ-A31Y SZ-A22Y
		2NO 1NO+1NC 2NO	SZ-A20Y SZ-A11Y SZ-A02Y

● **Dimensions and contact arrangement diagrams**

Same as the standard type auxiliary contact blocks.  
[See page 01/77.](#)

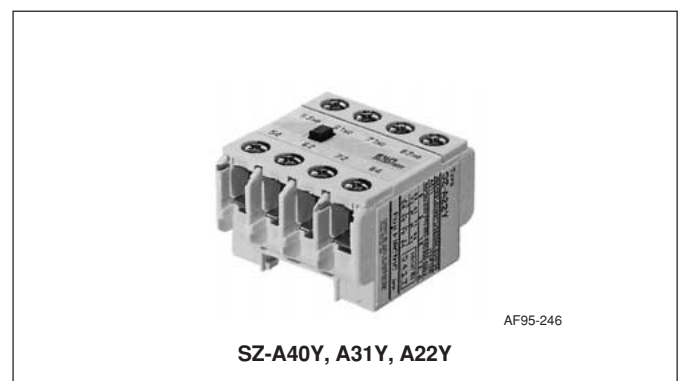

# Magnetic Contactors and Starters

## SC and SW series

### Optional unit

#### ■ Optional unit

Optional unit	Description	Type	Used with	Further information
Auxiliary contact block	<b>Front mounting</b> (Bifurcated) 4NO 3NO+1NC 2NO+2NC 2NO 1NO+1NC 2NC 2NO+2NC (Overlapping) 1NO+1NC (Overlapping)	<b>SZ-A40</b> <b>SZ-A31</b> <b>SZ-A22</b> <b>SZ-A20</b> <b>SZ-A11</b> <b>SZ-A02</b> <b>SZ-A222</b> <b>SZ-A111</b>	SC-03 to N3	<a href="#">Page 01/77</a>
	<b>Front mounting</b> (Single button) 4NO 3NO+1NC 2NO+2NC	<b>SZ-A40H</b> <b>SZ-A31H</b> <b>SZ-A22H</b>	SC-03 to N3	
	<b>Side mounting</b> (Bifurcated) 1NO+1NC <b>Side mounting</b> (Single button) 1NO+1NC 1NO+1NC 1NO+1NC 1NO+1NC	<b>SZ-AS1</b>  <b>SZ-AS2</b> <b>SZ-AS1H</b> <b>SZ-AS2H</b> <b>SZ-AS3H</b>	SC-03 to N3  SC-N4 to N12 SC-03 to N3 SC-N4 to N12 SC-N14, N16	
Auxiliary contact block with quick connection terminals	4NO 3NO+1NC 2NO+2NC  2NO 1NO+1NC 2NC	<b>SZ-A40Y</b> <b>SZ-A31Y</b> <b>SZ-A22Y</b>  <b>SZ-A20Y</b> <b>SZ-A11Y</b> <b>SZ-A02Y</b>	SC-03Y, 0Y, 05Y, 5-1Y	<a href="#">Page 01/73</a>
Operation counter unit	<b>Without alarm contact</b>	<b>SZ-J</b>	SC-03 to N3	<a href="#">Page 01/83</a>
	<b>With alarm contact</b> At 1 million operations At 2 million operations At 3 million operations At 4 million operations At 5 million operations At 6 million operations At 7 million operations At 8 million operations	<b>SZ-J1</b> <b>SZ-J2</b> <b>SZ-J3</b> <b>SZ-J4</b> <b>SZ-J5</b> <b>SZ-J6</b> <b>SZ-J7</b> <b>SZ-J8</b>	SC-03 to 5-1	
Main circuit surge suppression unit	<b>Front mounting</b>  <b>Side mounting</b>	<b>SZ-ZM1</b> <b>SZ-ZM3</b> <b>SZ-ZM2</b> <b>SZ-ZM4</b>	SC-03 to 5-1 SC-N1 to N3 SC-03 to 5-1 SC-N1 to N3	<a href="#">Page 01/81</a>
Mechanical interlock unit		<b>SZ-RM</b>	SC-03 to N3	<a href="#">Page 01/82</a>
Power connection kit for reversing		<b>SZ-RW1</b> <b>SZ-RW2</b> <b>SZ-RW3</b> <b>SZ-RW4</b> <b>SZ-RW5</b> <b>SZ-RW6</b>	SC-03, 0 SC-05 SC-4-0, 4-1 SC-5-1 SC-N1, N2 SC-N2S, N3	<a href="#">Page 01/82</a>
Coil drive unit for IC output	<b>Relay type</b> Top mounting  Left-side mounting	<b>SZ-CD1</b> <b>SZ-CD3</b> <b>SZ-CD5</b>	SC-03 to 5-1 SC-N1 to N3 SC-N4 to N12	<a href="#">Page 01/78</a>
	<b>SSR type</b> Top mounting  Left-side mounting	<b>SZ-03/CD2-24</b> <b>SZ-CD4</b> <b>SZ-CD6A</b>	SC-03 to 5-1 SC-N1 to N3 SC-N4 to N12	
3-pole parallel plate terminal	(2 pcs/set)	<b>SZ-SP1</b> <b>SZ-SP2</b> <b>SZ-SP3</b> <b>SZ-SP4</b> <b>SZ-SP5</b>	SC-03, 0, 05 SC-4-0, 4-1, 5-1 SC-N1, N2 SC-N2S, N3 SC-N4, N5	<a href="#">Page 01/71</a>

Optional unit	Description	Type	Used with	Further information
3-pole parallel plate terminal	(2pcs/set)	<b>SZ-SP6</b> <b>SZ-SP7</b> <b>SZ-SP8</b> <b>SZ-SP9</b> <b>SZ-SP10</b> <b>SZ-SP11</b>	SC-N6 SC-N7 SC-N8, N10 SC-N11, N12 SC-N14 SC-N16	<a href="#">Page 01/71</a>
Coil surge suppression unit	<b>Varistor</b> 24 to 48V AC/DC 100 to 250V AC/DC  380 to 440V AC  24 to 48V AC/DC(with LED) 100 to 250V AC/DC(with LED)  24 to 48V AC/DC 100 to 250V AC/DC  380 to 440V AC  24 to 48V AC 100 to 250V AC 380 to 440V AC  <b>CR</b> 24 to 48V AC/DC 100 to 250V AC/DC  24 to 48V AC/DC(with LED) 100 to 250V AC/DC(with LED)  24 to 48V AC 100 to 250V AC  24 to 48V DC 100 to 250V DC  24 to 48VAC 100 to 250V AC	<b>SZ-Z1</b> <b>SZ-Z2</b>  <b>SZ-Z3</b>  <b>SZ-Z6</b> <b>SZ-Z7</b>  <b>SZ-Z31</b> <b>SZ-Z32</b>  <b>SZ-Z33</b>  <b>SZ-Z41</b> <b>SZ-Z42</b> <b>SZ-Z43</b>  <b>SZ-Z4</b> <b>SZ-Z5</b>  <b>SZ-Z8</b> <b>SZ-Z9</b>  <b>SZ-Z34</b> <b>SZ-Z35</b>  <b>SZ-Z36</b> <b>SZ-Z37</b>  <b>SZ-Z44</b> <b>SZ-Z45</b>	SC-03 to 5-1, SC03/G to 5-1/G SC-03 to 5-1, SC-03/G to 5-1/G  SC-03 to 5-1  SC-03 to 5-1, SC-03/G to 5-1/G SC-03 to 5-1, SC-03/G to 5-1/G  SC-N1 to N3, SC-N1/G to N3/G SC-N1 to N3, SC-N1/G to N3/G  SC-N1 to N3  SC-N4 SC-N4 SC-N4  SC-03 to 5-1, SC-03/G to 5-1/G SC-03 to 5-1, SC-03/G to 5-1/G  SC-03 to 5-1, SC-03/G to 5-1/G SC-03 to 5-1, SC-03/G to 5-1/G  SC-N1 to N3 SC-N1 to N3  SC-N1/G to N3/G SC-N1/G to N3/G  SC-N4 SC-N4	<a href="#">Page 01/80</a>
Contact welding detector	1NO 100 to 250V AC 1NC 100 to 250V AC	<b>SZ-BW2A</b> <b>SZ-BW2B</b>	SC-03 to N16	<a href="#">Page 01/79</a>
Fault detector unit	SPDT 100 to 120V AC SPDT 200 to 240V AC	<b>SY-F-A3/M</b> <b>SY-F-A4/M</b>	SC-03 to N16	Contact FUJI
Contact transfer protector	100 to 127V AC 200 to 250V AC	<b>SZ-RC1</b> <b>SZ-RC2</b>	SC-03 to N16	Contact FUJI
Terminal cover	<b>For contactor</b>          <b>For contactor</b>          <b>For starter</b>          <b>For reversing contactor</b>	<b>SZ-T1</b> <b>SZ-T2</b> <b>SZ-T3</b> <b>SZ-T4</b> <b>SZ-T22</b> <b>SZ-T23</b>  <b>SZ-N4T</b> <b>SZ-N6T</b> <b>SZ-N7T</b> <b>SZ-N8T</b> <b>SZ-N11T</b>  <b>SZ-N4T, SZ-WN4T</b> <b>SZ-N6T, SZ-WN6T</b> <b>SZ-N7T, SZ-WN7T</b> <b>SZ-N8T, SZ-WN8T</b> <b>SZ-N8T, SZ-WN10T</b> <b>SZ-N11T, SZ-WN11T</b>  <b>SZ-N4RT1, T2</b> <b>SZ-N6RT1, T2</b> <b>SZ-N7RT1, T2</b> <b>SZ-N8RT1, T2</b> <b>SZ-N11RT1, T2</b>	SC-03, 0 SC-05 SC-4-0, 4-1 SC-5-1 SC-N1, N2 SC-N2S, N3  SC-N4, N5 SC-N6 SC-N7 SC-N8, N10 SC-N11, N12  SW-N4/3H, N5/3H SW-N6/3H SW-N7/3H SW-N8/3H SW-N10/3H SW-N11/3H, N12/3H  SW-N4RM, N5RM SW-N6RM SW-N7RM SW-N8RM, N10RM SW-N11RM, N12RM	<a href="#">Page 01/84</a>

Magnetic Contactors and Starters  
**SC and SW series**  
**Optional unit**

Optional unit	Description	Type	Used with	Further information
Terminal cover	<b>For thermal overload relay</b>	SZ-T10 SZ-T11 SZ-T12 SZ-T13 SZ-T14 SZ-T15 SZ-RN6T SZ-T16 SZ-T17	SZ-HB SZ-HC TR-0N/3, TK-0N TR-5-1N/3, TK-5-1N TR-N2H/3, TK-N2H TR-N3H/3, TK-N3H TR-N6H/3, TKN6H TR-N2/3, TK-N2 TR-N3/3, TK-N3	<a href="#">Page 01/84</a>
	<b>For auxiliary contact block</b> For 4-pole front mount For 2-pole front mount For 1-pole front mount	SZ-T5 SZ-T6 SZ-T7	SZ-A40, A31, A22, A222 SZ-A20, A11, A02, A111 SZ-AS1, AS2	
Insulation barrier	<b>For contactor</b>	SZ-B1	SC(SW)-N4 to N7, TR(TK)-N6H	<a href="#">Page 01/85</a>
		SZ-B2	SC(SW)-N8 to N12, TR(TK)N10H/3 to N12H/3	
Off-delay release unit	100V AC 50/60Hz 110V AC 50/60Hz 200V AC 50/60Hz 220V AC 50/60Hz	SZ-DE100 SZ-DE110 SZ-DE200 SZ-DE220	SC-03/G to 5-1/G	<a href="#">Page 01/54</a>
	100-110V AC, 50/60Hz	SZ-N1/GDE SZ-N2S/GDE SZ-N5/DE SZ-N6/DE SZ-N8/DE SZ-N11/DE SZ-N14/DE	SC-N1/G, N2/G SC-N2S/G, N3/G SC-N4/SE, N5 SC-N6, N7 SC-N8, N10 SC-N11, N12 SC-N14	
	200-220V AC, 50/60Hz	SZ-N1/GDE SZ-N2S/GDE SZ-N5/DE SZ-N6/DE SZ-N8/DE SZ-N11/DE	SC-N1/G, N2/G SC-N2S/G, N3/G SC-N4/SE, N5 SC-N6, N7 SC-N8, N10 SC-N11, N12	
Live-section cover	<b>For contactor</b>	SZ-JC1 SZ-JC2 SZ-JC3 SZ-JC4 SZ-N1J SZ-N2SJ	SC-03, 0 SC-05 SC-4-0, 4-1 SC-5-1 SC-N1, N2 SC-N2S, N3	<a href="#">Page 01/86</a>
		SZ-N4J SZ-N6J SZ-N7J SZ-N8J SZ-N11J	SC-N4, N5 SC-N6 SC-N7 SC-N8, N10 SC-N11, N12	
	<b>For starter</b>	SZ-JW1 SZ-JW2 SZ-JW3 SZ-JW4 SZ-WN1J SZ-WN2SJ  SZ-WN4J SZ-WN6J SZ-WN7J SZ-WN8J SZ-WN10J SZ-WN11J	SW-03/3H, 0/3H SW-05/3H SW-4-0/3H, 4-1/3H SW-5-1/3H SW-N1/3H, N2/3H SW-N2S/3H, N3/3H  SW-N4/3H, N5/3H SW-N6/3H SW-N7/3H SW-N8/3H SW-N10/3H SW-N11/3H, N12/3H	
<b>For reversing starter</b>	SZ-WN4RJ SZ-WN6RJ SZ-WN7RJ SZ-WN8RJ SZ-WN10RJ SZ-WN11RJ	SW-N4RM, N5RM SW-N6RM SW-N7RM SW-N8RM SW-N10RM SW-N11RM, N12RM		



**Auxiliary contact blocks SZ-A**

■ **Features**

- Easy attaching of auxiliary contact block  
 This contact block can be attached to magnetic motor starter and contactor with a snap-on fitting. Auxiliary contacts can be added easily at site. When a front mounting block is used, there is no need to enlarge contactor installation space. This helps to make the control panel smaller.
- Bifurcated contact is standard  
 High reliable bifurcated contact makes it possible to input directly to electronic control circuits like programmable logic controllers.
- Auxiliary contact block with single button contacts is also available.
- Terminal number conforms to IEC standard

■ **Standards**

Except overlap and single button contact type



■ **Performance**

Operating frequency: 1800 times/hour  
 Mechanical durability: 10 million operations  
 Electrical durability:  
 500,000 operations (at 220V AC-15)

Type	Contact arrangement
<b>Front mounting</b>	
SZ-A40, A40H	4NO
SZ-A31, A31H	3NO+1NC
SZ-A22, A22H	2NO+2NC
SZ-A20	2NO
SZ-A11	1NO+1NC
SZ-A02	2NC
SZ-A111	1NO+1NC (Overlapping)
SZ-A222	2NO+2NC (Overlapping)
<b>Side mounting</b>	
SZ-AS1, AS1H	1NO+1NC
SZ-AS2, AS2H	1NO+1NC
SZ-AS3H	1NO+1NC

■ **Caution on use**

1. Front mounting auxiliary contact block and side mounting block cannot be attached to one contactor at the same time.
2. Only one front mounting block can be attached to one contactor.
3. Where mechanical latch unit is already attached, only side mounting auxiliary contact block can be attached.
4. Where interlock unit is already attached, side mounting auxiliary contact block can be attached on one side only.



■ **Ratings**

Type	Thermal current (A)	Make/break current (A)	Rated operational current (A)*2			Minimum voltage/current
			AC Voltage	Ind. load (AC-15)	Res. load (AC-12)	
SZ-A□	10	60 (60)	110V	6 (6)	10 (10)	5V DC
SZ-AS1		30 (60)	220V	3 (6)	8 (10)	3 mA
SZ-AS2		15 (40)	440V	1.5 (4)	5 (10)	(24 V DC
SZ-A□H		12 (25)	550V	1.2 (2.5)	5 (10)	10mA)
SZ-AS1H						
SZ-AS2H SZ-AS3H						

Note: \*1 Enter the contact arrangement code in the □ mark.  
 \*2 DC ratings: Same as the auxiliary contact ratings of standard type contactors or contactors with single button contacts.  
 • ( ): In case of SZ-A□H (single button contact)

■ **Dimensions, mm**

SZ-A40, A40H, A31, A31H, A22, A22H, A222  
 SZ-A20, A11, A02, A111

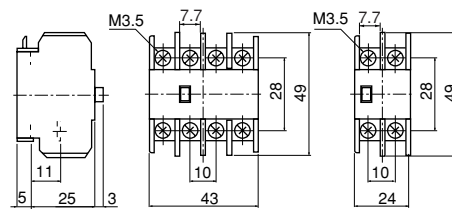

Mass: 36g

Mass: 20g

SZ-AS3H

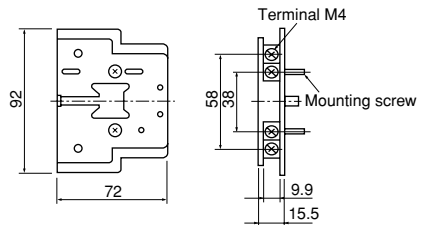

Mass: 75g

SZ-AS1, AS1H

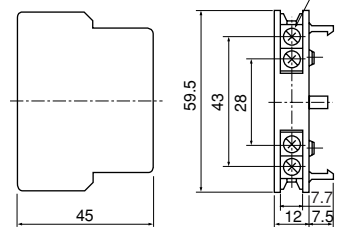

Mass: 28kg

SZ-AS2, AS2H

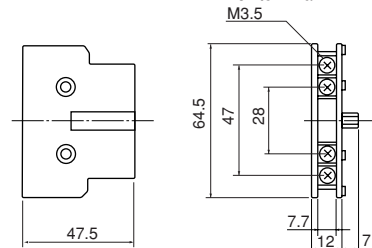

Mass: 33kg

■ **Contact arrangement**

SZ-A40, A40H	SZ-A20	SZ-AS1, AS2, AS1H, AS2H, AS3H
4NO	2NO	1NO+1NC
53 63 73 83 54 64 74 84	53 63 54 64	53 61 54 62 In case of left side mounting
SZ-A31, A31H	SZ-A11	
3NO+1NC	1NO+1NC	
53 61 73 83 54 62 74 84	53 61 54 62	
SZ-A22, A22H	SZ-A02	SZ-AS1, AS2, AS1H, AS2H, AS3H
2NO+2NC	2NC	1NO+1NC
53 61 71 83 54 62 72 84	51 61 52 62	71 83 72 84
SZ-A222	SZ-A111	
2NO+2NC	1NO+1NC	In case of right side mounting
57 65 75 87 58 66 76 88	57 65 58 66	

# Magnetic Contactors and Starters

## SC and SW series

### Optional unit

#### Coil drive units for IC output SZ-CD

This unit is designed to carry out ON-OFF control for contactors with output (24V DC) from the electronic controller. It can be attached to a side or top of a contactor, thus saving on installation space.

#### ■ Features

- This unit operates at, 24V DC.
- Module type allows easy attachment and removal.
- SZ-CD5 and -CD6 can be installed individually and rail mounted.
- Surge suppression function (except SZ-CD5)
- This unit has a built-in surge suppression device (varistor) to protect electronic equipment from surges which occur when the coil is de-energized.



Type		Used with
<b>SZ-CD1</b> <b>SZ-CD3</b> <b>SZ-CD5</b>	With relay output	SC-03 to 5-1 SC-N1 to N3 SC-N4 to N12
<b>SZ-03/CD2-24</b> <b>SZ-CD4</b> <b>SZ-CD6</b>	With SSR output	SC-03 to 5-1 SC-N1 to N3 SC-N4 to N12

#### ■ Specifications

Description		<b>SZ-CD1</b>	<b>SZ-CD3, CD5</b>	<b>SZ-03/CD2-24, CD4, CD6</b>
Coil	Rated voltage	24V DC	24V DC	24V DC
	Pick-up voltage (at 20°C)	85% or less of rated voltage	85% or less of rated voltage	70% or less of rated voltage
	Drop-out voltage (at 20°C)	Over 5% of rated voltage	Over 5% of rated voltage	Over 5% of rated voltage
	Max. allowable voltage	130% or less of rated voltage	130% or less of rated voltage	110% or less of rated voltage
	Power consumption	0.2W(8.3mA)	0.2W(8.3mA)	0.36W(15mA)
Contact	Output device	Relay output	Relay output	SSR output
	Max. make/break voltage	250V AC, 110V DC	250V AC	100-240V AC
	Operating time(ms)	2-5	2-5(SZ-CD5: 3-6)	1 or less

#### ■ Dimensions, mm

##### SZ-CD1,03/CD2-24 (Top mount)

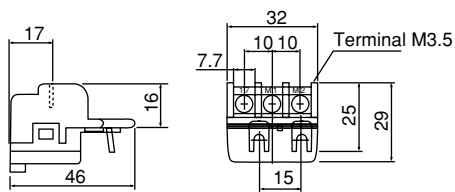

Mass: 26g

##### SZ-CD3,CD4 (Top mount)

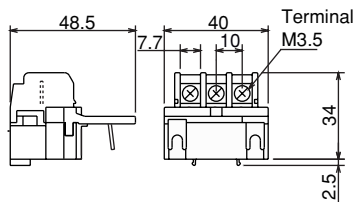

Mass: 28g

##### SZ-CD5,CD6 (Side mount)

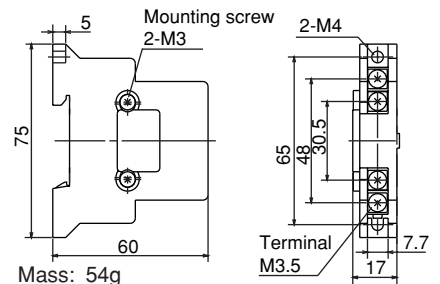

Mass: 54g

#### ■ Wiring diagrams

##### SZ-CD1

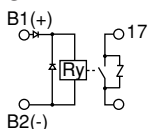

##### SZ-03/CD2-24

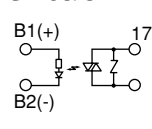

##### SZ-CD3

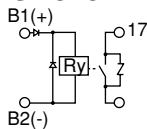

##### SZ-CD4

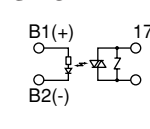

##### SZ-CD5

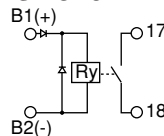

##### SZ-CD6

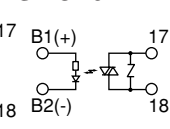

**Contact welding detectors**  
**SZ-BW**

Overcurrents generated when short circuit occurs may cause welding of a contactor's main contact. This detector can detect malfunctions due to welded main contacts when power to a coil is OFF. When welding of a main contact occurs, the alarm lamp (Red) of the operating indicator lights and a trip signal is sent to the line-side breaker to protect the system.

**■ Features**

- Permits detection of even one welded main contact
- Wide voltage range of 100 to 250V AC
- Provided with an operation test switch
- One detector is sufficient for a reversing contactor and starter.



Type	Used with contactor and starter	Coil voltage*
	Contactor Starter	
<b>SZ-BW2A</b>	SC-03 to SC-N16 SW-03/3H to N14/3H	100 to 240V AC
<b>SZ-BW2B</b>	SC-03RM to SC-N14RM SW-03RM/3H to N14RM/3H	50/60Hz

Note: \* 100 to 240V AC 50/60Hz for frame size 03 to N4  
 100 to 220V AC 50/60Hz for frame size N5 to N14

**■ Type number nomenclature**

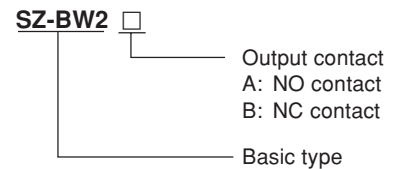

**■ Specifications**

Type	SZ-BW2A	SZ-BW2B
Power supply	100 —250V AC	50/60Hz
Output contact arrangement	1NO	1NC
Rated operational current	1A at 250V AC	
Detecting time	200 to 400ms	
Operating voltage range	85 to 110% of rated voltage	
Ambient temperature and humidity	-5 to 50°C, 45 to 85%RH	
Operating indicator	Power ON: Green LED Detection of welded contact: Red LED	

**■ Timing diagram/SZ-BW2A**

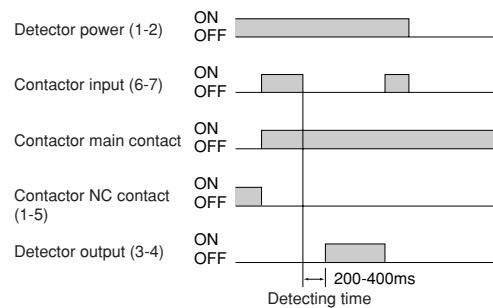

**■ Dimensions, mm**

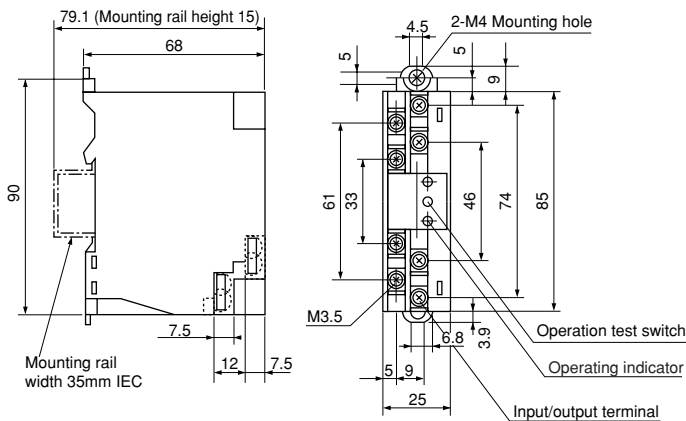

Mass: 120g

**■ Wiring diagram (Example)**

Non-reversing contactor and starter

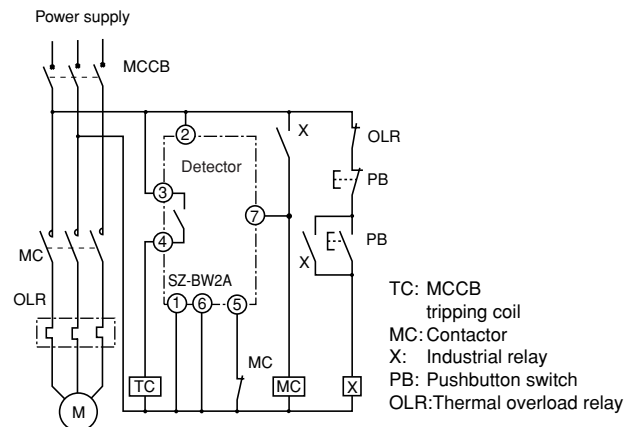

# Magnetic Contactors and Starters

## SC and SW series

### Optional unit

#### Coil surge suppression units SZ-Z

##### ■ Description

This unit suppresses coil surge voltage due to contactor ON-OFF operations. This unit can be easily connected to contactor coil terminals.

Varistor types cut the peak value of surge voltages and CR types suppress rapid increases of surge voltage.

Standard type contactors SC-N5 to N16 are provided with surge suppression devices.

##### Coil surge suppression unit (for SC-03 to 5-1, SC-N1 to N4)

Type	Device	Coil voltage	Used with
SZ-Z1	Varistor	24–48V AC/DC	SC-03 to 5-1
SZ-Z2	Varistor	100–250V AC/DC	
SZ-Z3	Varistor	380–440V AC	
SZ-Z4	CR	24–48V AC/DC	SC-03/G to 5-1/G
SZ-Z5	CR	100–250V AC/DC	
SZ-Z6 *	Varistor	24–48V AC/DC	
SZ-Z7 *	Varistor	100–250V AC/DC	
SZ-Z8 *	CR	24–48V AC/DC	SC-N1 to N3
SZ-Z9 *	CR	100–250V AC/DC	
SZ-Z31	Varistor	24–48V AC/DC	SC-N1/G to N3/G
SZ-Z32	Varistor	100–250V AC/DC	
SZ-Z33	Varistor	380–440V AC	
SZ-Z34	CR	24–48V AC	SC-N1 to N3
SZ-Z35	CR	100–250V AC	
SZ-Z36	CR	24–48V DC	SC-N1/G to N3/G
SZ-Z37	CR	100–250V DC	
SZ-Z41	Varistor	24–48V AC	SC-N4
SZ-Z42	Varistor	100–250V AC	
SZ-Z43	Varistor	380–440V AC	
SZ-Z44	CR	24–48V AC	
SZ-Z45	CR	100–250V AC	

Note: \* With LED operating indicator



##### ■ Dimensions, mm

###### SZ-Z1 to Z5

###### SZ-Z24, Z25

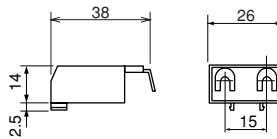

Mass: 14g

###### SZ-Z6 to Z9

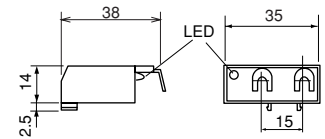

Mass: 16g

###### SZ-Z31 to Z37

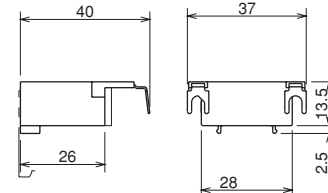

Mass: 15g

###### SZ-Z41 to Z45

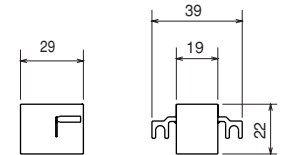

Mass: 15g

##### ■ Characteristics (coil rated 200V AC)

###### ● Without coil surge suppression unit

When current through a coil is interrupted, the sudden change of coil current, induces an abrupt surge voltage due to the coil inductance. The surge voltage sometimes produces noise which can damage or cause adjacent electronic devices to malfunction.

SC-0 (0.1msec/div, 1000V/div)  
200V AC coil

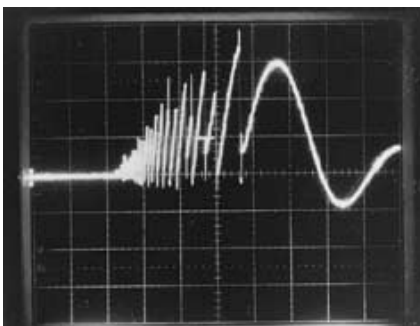

CP-487

###### ● With coil surge suppression unit Varistor type

A surge voltage that exceeds a certain value causes a current to flow through the varistor connected in parallel with the coil, thereby suppressing peaks of the surge voltage. This surge suppression unit can be used in both AC and DC circuits.

SC-0+SZ-Z2 (2msec/div, 200V/div)  
200V AC coil

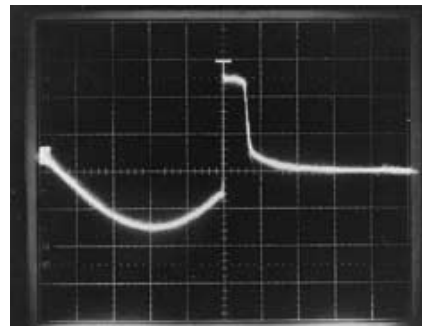

CP-489

###### ● With coil surge suppression unit CR type

A CR (Capacitor-resistor) circuit connected in parallel with the coil suppresses the abrupt increase of surge voltage (dv/dt characteristics) by lowering the surge voltage oscillation frequency.

This surge suppression unit can be used in both AC and DC circuits.

SC-0+SZ-Z5 (2msec/div, 200V/div)  
200V AC coil

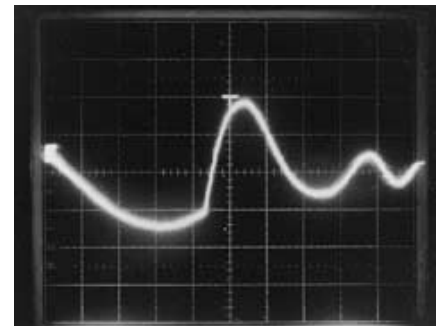

CP-488

**Main circuit surge suppression units SZ-ZM**

■ **Description**

This unit consists of delta connected capacitor (C) and resistor (R).  
 When contactor is energized or de-energized, a surge voltage is generated from motor circuit. This unit suppresses this surge voltage and protects electronic equipment from malfunction or damage.  
 Space saving, front mounting type (SZ-ZM1) and side mounting type (SZ-ZM2), which allows simultaneous use of other front mounting optional unit.

Type	Mounting	Voltage	CR constant	Used with
<b>SZ-ZM1</b>	Front	250V AC	C=0.22μF R=100Ω	SC-03 to SC-5-1
<b>SZ-ZM2</b>	Side	50/60Hz	C=0.33μF R=47Ω	SC-N1 to SC-N3

Note: SZ-ZM1 is not applicable to SC-5-1 with auxiliary contact 2NO+2NC.

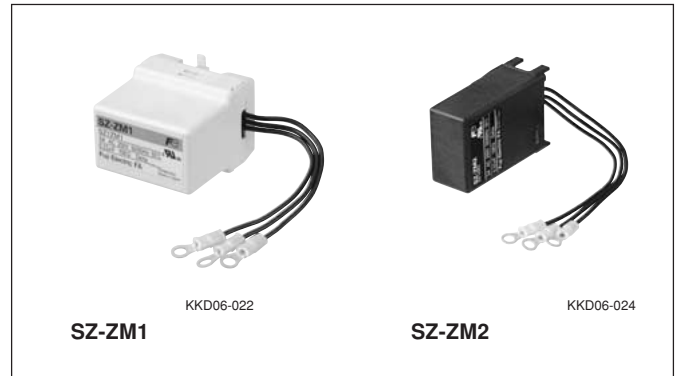

■ **Performance**

**Dielectric strength:** 230% × Rated voltage, 1min. between terminals  
 2 × Rated voltage + 1,000V, between terminals and case  
**Insulation resistance:** 2,000MΩ or more  
**Capacitance tolerance:** ±10% or less at 1kHz

■ **Characteristics**

- **(200V AC 2.2kW motor)**
- **With surge suppression unit** (5μsec/div 200V/div)

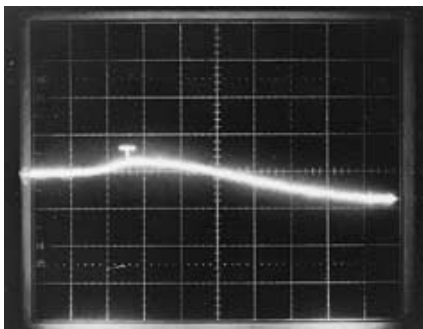

CP-486

- **Without surge suppression unit** (5μsec/div 200V/div)

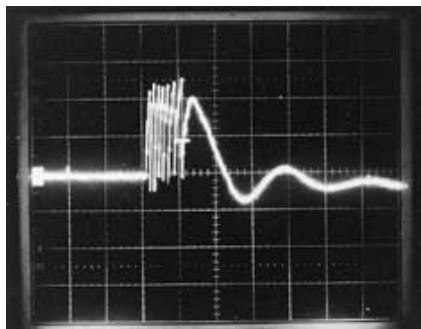

CP-485

■ **Wiring example**

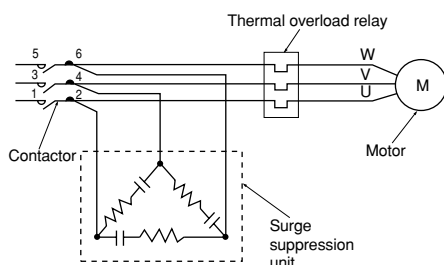

■ **Dimensions, mm**  
**SZ-ZM1, ZM3**

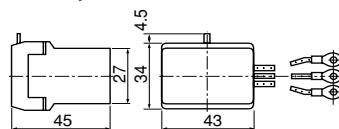

Mass: 60g

■ **SZ-ZM2, ZM4**

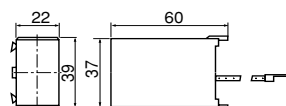

Mass: 60g

■ **Mounting methods**

- **Front mounting/SZ-ZM1, ZM3**  
 Set the unit on the contactor and slide it in direction ②.  
 Make sure that the unit's hook is in the mounting slot.  
 To detach the unit, push up on the unit's hook and move the unit in the reverse of direction ②.  
 Connect the 3 lead wires of the unit to the contactor's load side terminals 2, 4 and 6. Wires can be connected to any of the terminals 2, 4 or 6.

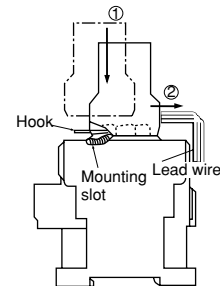

- **Side mounting /SZ-ZM2, ZM4**

Push the protruding portions of the unit into the mounting slots of the contactor. Connect the 3 lead wires of the unit to the contactor's load side terminals 2, 4 and 6. Wires can be connected to any of the terminals 2,4 or 6.

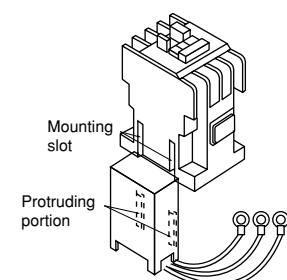

# Magnetic Contactors and Starters

## SC and SW series

### Optional unit

#### Mechanical interlock units and power connection kit for reversing

This SZ-RM unit consists of an interlock block, which mechanically prevents the simultaneous engagement of forward and reverse contactors, and a connector block. A reversing contactor can be easily assembled with this unit at site.

An interlock mechanism prevents the engagement of 2 contactors at the same time.

Interlock unit		Power connection kit for reversing		
Type	Used with	Type	Color	Used with
<b>SZ-RM</b>	SC-03 to N3	<b>SZ-RW1</b>	Blue	SC-03, SC-0
		<b>SZ-RW2</b>	Black	SC-05
		<b>SZ-RW3</b>	Yellow	SC-4-0, SC-4-1
		<b>SZ-RW4</b>	White	SC-5-1
		<b>SZ-RW5</b>	White	SC-N1, SC-N2
		<b>SZ-RW6</b>	White	SC-N2S, SC-N3

#### ■ Mounting methods

- Position an interlock block between two contactors so that the tall, square projections ① on the movable portions on either side of the interlock block fit into the square holes ② on the sides of the contactors. The short, round projections ③ on the sides of the interlock block should fit into the round holes ④ on the sides of the contactors.
- Insert the guides ⑤ on the ends of the connector block into the slots ⑥ in the sides of the contactors and push the connector block in between the contactors until the frames ⑦ of the projecting windows on the ends of the connector block catch firmly on the hook-like projections ⑧ on the interlock block.
- After connecting the contactors to each other, make sure that they operate smoothly by pressing down the movable manual operator one at a time.
- To separate the contactors, insert the end of a flat-bladed screwdriver under the frame ⑦ of one of the projecting windows on the connector block and lift it up and over the hook-like projection ⑧ on the interlock block. While lifting up on the frame ⑦, push against the connector block to eject it from between the contactors.

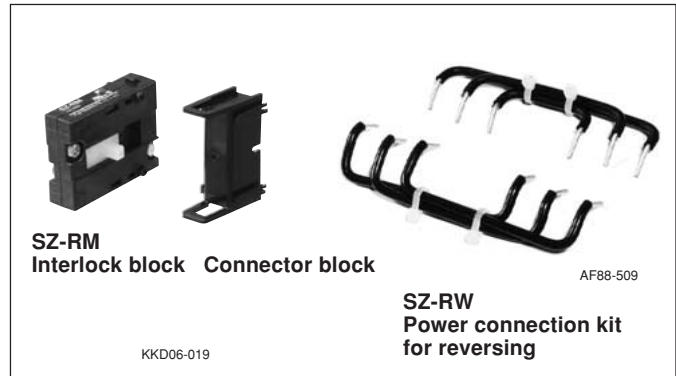
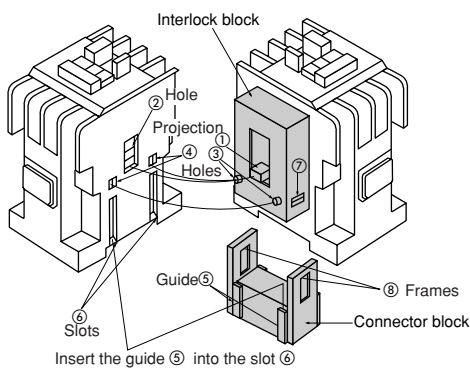

#### ■ Dimensions, mm

##### Interlock block

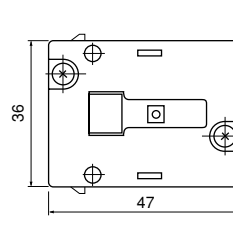

Mass: 18g

##### Connector block

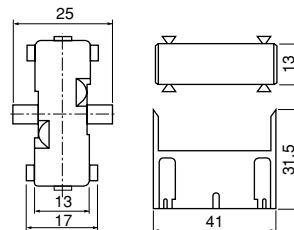

Mass: 4.2g

#### Power connection kit for reversing

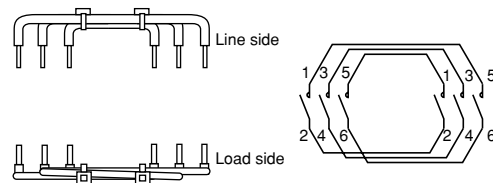

#### Cautions on attaching interlock unit to SC-03 and SC-0

Insert the protruded portion of the interlock unit into the upper (not lower) part of two slots on the side of the contactor by pressing the manual operator of the contactor.

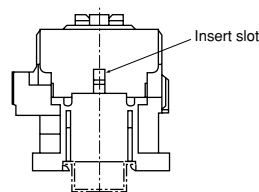

**Operation counter units for SC-03 to N3**

■ **Features**

This unit counts the ON-OFF operation times of a contactor. The contact lifetime can be estimated at a glance. This operation counter unit is a mechanical type counter which can be easily attached to the SC series contactors (Frame size 03 to N3) with snap-on fittings. Before, the operation times of contactors were estimated from the operation status of other equipment. However, the operation times of contactors can be precisely counted and easily checked with this unit.

The date for periodical maintenance and contact lifetime can be estimated directly counting the operation times of contactors.

So preventive maintenance of important facilities or plant become more effective. 2 types (without and with output contact type) are available. The first one only counts and display the operation times up to 9,999,999. The another type is an output contact type which outputs the alarm output with a built-in reed switch after counting and displaying specified operation times (fixed).

■ **Specifications**

Type	SZ-J	SZ-J□
Alarm output contact	Not provided	Provided
Number of digits	7 digits	
Counting method	The counter increments by one each time the contactor completes one ON-OFF operation	
Counting speed	Max. 10Hz	
Reset function (to 0)	Not provided	
Output contact Arrangement	—	1NO
Rating	—	24V AC/DC 100mA
Making current	—	Max. 0.4A
Mechanical durability	10 million operations	
Used with	SC-03 to SC-N3	SC-03 to SC-5-1

■ **Types and output contact operation**

Type	Preset operation value	
	ON	OFF
SZ-J	—	—
SZ-J1	1 million	3 million
SZ-J2	2 million	4 million
SZ-J3	3 million	5 million
SZ-J4	4 million	6 million
SZ-J5	5 million	7 million
SZ-J6	6 million	8 million
SZ-J7	7 million	9 million
SZ-J8	8 million	0

■ **Wiring diagram (Example)**

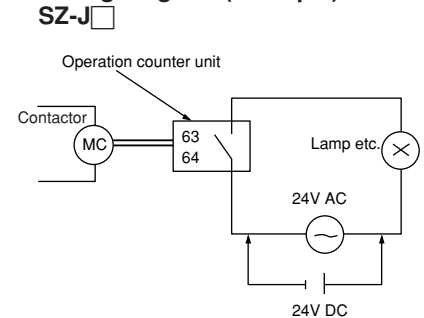

■ **Dimensions, mm**

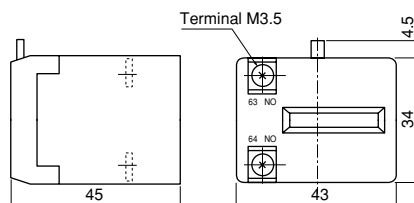

Mass: SZ-J 35g  
 SZ-J1 to J8 39g



■ **Operation**

**SZ-J**  
**Without output contact**

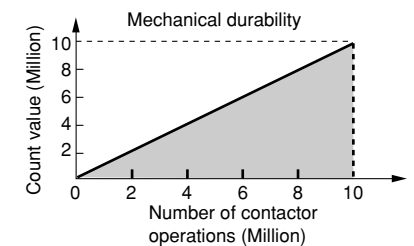

**SZ-J□**  
**With output contact**  
 Example SZ-J5

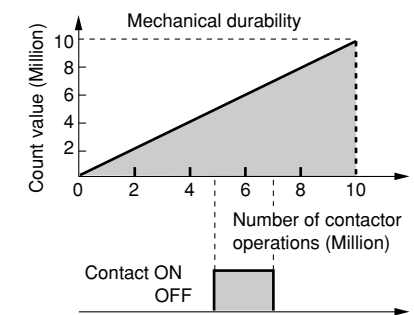

Note: The SZ-J□ operation counters (with alarm output contact) continue counting after an alarm is output. The alarm output is maintained for about 2 million operations.

# Magnetic Contactors and Starters

## SC and SW series

### Optional unit

#### Terminal covers

The SZ-T type terminal cover conforms to DIN 57106 and VDE 0106 Teil 100 requirements regarding worker safety. The cover increases safety during maintenance and inspection.

Description	Type	Used with
For contactor	<b>SZ-T1</b>	SC-03, 0, SH-4
	<b>SZ-T2</b>	SC-05, SH5
	<b>SZ-T3</b>	SC-4-0, 4-1
	<b>SZ-T4</b>	SC-5-1, SJ-1SG
	<b>SZ-T22</b>	SC-N1, N2
	<b>SZ-T23</b>	SC-N2S, N3
	<b>SZ-N4T</b>	SC-N4, N5
	<b>SZ-N6T</b>	SC-N6
	<b>SZ-N7T</b>	SC-N7
	<b>SZ-N8T</b>	SC-N8, N10
	<b>SZ-N11T</b>	SC-N11, N12
For starter	<b>SZ-T1</b>	SW-03/3H, 0/3H
	<b>SZ-T12</b>	
	<b>SZ-T2</b>	SW-05/3H
	<b>SZ-T12</b>	
	<b>SZ-T3</b>	SW-4-0/3H, 4-1/3H
	<b>SZ-T13</b>	SJ-1SWG
	<b>SZ-T4</b>	SW-5-1/3H
	<b>SZ-T13</b>	
	<b>SZ-T22</b>	SW-N1/3H, N2/3H
	<b>SZ-T16</b>	
	<b>SZ-T23</b>	SW-N2S/3H, N3/3H
	<b>SZ-T17</b>	
	<b>SZ-N4T</b>	SW-N4/3H, N5/3H
	<b>SZ-WN4T</b>	
<b>SZ-N6T</b>	SW-N6/3H	
<b>SZ-WN6T</b>		
<b>SZ-N7T</b>	SW-N7/3H	
<b>SZ-WN7T</b>		
<b>SZ-N8T</b>	SW-N8/3H	
<b>SZ-WN8T</b>		
<b>SZ-N8T</b>	SW-N10/3H	
<b>SZ-WN10T</b>		
<b>SZ-N11T</b>	SW-N11/3H, N12/3H	
<b>SZ-WN11T</b>		
For auxiliary contact block	<b>SZ-T5</b>	SZ-A40, A31, A22, A222 SZ-A40H, A31H, A22H
	<b>SZ-T6</b>	SZ-A20, A11, A02, A111
	<b>SZ-T7</b>	SZ-AS1, AS2 SZ-AS1H, AS2H, AS3H
For thermal overload relay on-contactor mounting	<b>SZ-T12</b>	TR-0N, TK-0N
	<b>SZ-T13</b>	TR-5-1N, TK-5-1N
	<b>SZ-T16</b>	TR-N2, TK-N2
	<b>SZ-T17</b>	TR-N3, TK-N3
For thermal overload relay separate mounting	<b>SZ-T14</b>	TR-N2H, TK-N2H
	<b>SZ-T15</b>	TR-N3H, TK-N3H
	<b>SZ-RN6T</b>	TR-N6H, TK-N6H
Thermal overload relay base unit for separate mounting	<b>SZ-T10</b>	SZ-HB
	<b>SZ-T11</b>	SZ-HC
For coil drive unit	<b>SZ-T7</b>	SZ-CD5, SZ-CD6

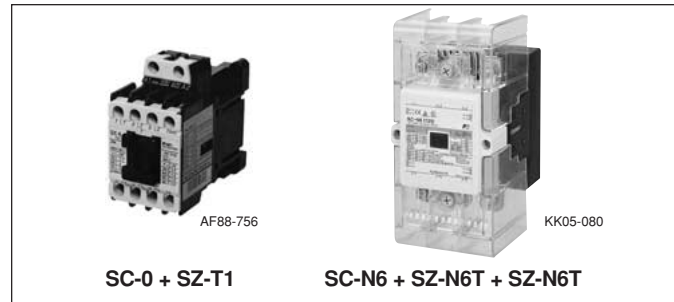

Description	Type	Used with
For reversing contactor	<b>SZ-T1</b>	SC-03RM, 0RM
	<b>SZ-T2</b>	SC-05RM
	<b>SZ-T3</b>	SC-4-0RM, 4-1RM
	<b>SZ-T4</b>	SC-5-1RM
	<b>SZ-T22</b>	SC-N1RM, N2RM
	<b>SZ-T23</b>	SC-N2SRM, N3RM
	<b>SZ-N4RT1</b>	SC-N4RM, N5RM
	<b>SZ-N4RT2</b>	
	<b>SZ-N6RT1</b>	SC-N6RM
	<b>SZ-N6RT2</b>	
	<b>SZ-N7RT1</b>	SC-N7RM
<b>SZ-N7RT2</b>		
<b>SZ-N8RT1</b>	SC-N8RM, N10RM	
<b>SZ-N8RT2</b>		
<b>SZ-N11RT1</b>	SC-N11RM, N12RM	
<b>SZ-N11RT2</b>		
For reversing starter	<b>SZ-T1</b>	SW-03RM, 0RM
	<b>SZ-T12</b>	
	<b>SZ-T2</b>	SW-05RM
	<b>SZ-T12</b>	
	<b>SZ-T3</b>	SW-4-0RM, 4-1RM
	<b>SZ-T13</b>	
	<b>SZ-T4</b>	SW-5-1RM
	<b>SZ-T13</b>	
	<b>SZ-T22</b>	SW-N1RM, N2RM
<b>SZ-T16</b>		
<b>SZ-T23</b>	SW-N2SRM, N3RM	
<b>SZ-T17</b>		

#### ■ Contactors and starters with terminal cover

Contactors, starters, industrial relays, and thermal overload relays with a terminal cover are also available as the finger-protected type for the European market. Suffix the code /T at the end of the type number, when ordering, for this type.

#### Example

**SC-03/T** type: Contactor **SC-03**+Terminal cover **SZ-T1**  
**SW-03/3HT** type: Starter **SW-03/3H**+Terminal cover **SZ-T1**+**SZ-T12**



**Terminal covers (Continued)**

■ **Dimensions, mm**  
**Contactors**

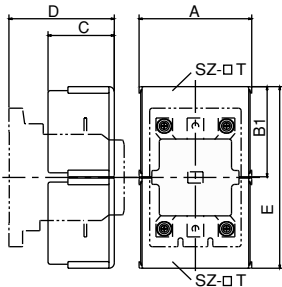

Fig.1

**Starters**

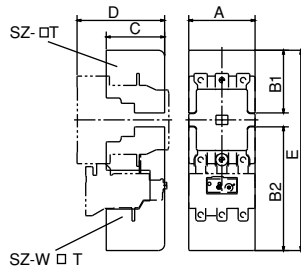

Fig.2

**Reversing contactors**

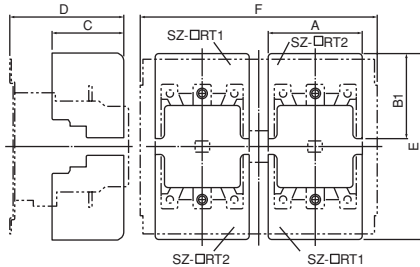

Fig.3

Type	Line side	Load side	A	B1	B2	C	D	E	F	Fig. No.
SZ-N4T	SZ-N4T	SZ-N4T	97.5	90	—	91.5	119*1	199	—	1
SZ-N6T	SZ-N6T	SZ-N6T	100	94.5	—	88	132	210	—	1
SZ-N7T	SZ-N7T	SZ-N7T	115	104	—	89	134	228	—	1
SZ-N8T	SZ-N8T	SZ-N8T	170	136	—	100	159	274	—	1
SZ-N11	SZ-N11T	SZ-N11T	185	175	—	116	175	352	—	1
SZ-N4T	SZ-WN4T	SZ-WN4T	97.5	90	143.5	91.5	119*1	252.5	—	2
SZ-N6T	SZ-WN6T	SZ-WN6T	100	94.5	186.5	88	132	302	—	2
SZ-N7T	SZ-WN7T	SZ-WN7T	115	104	193	89	134	317	—	2
SZ-N8T	SZ-WN8T	SZ-WN8T	170	136	237	100	159	375	—	2
SZ-N8T	SZ-WN10T	SZ-WN10T	170	136	228	100	159	366	—	2
SZ-N11T	SZ-WN11T	SZ-WN11T	185	175	304	116	175	481	—	2
SZ-N4RT1	SZ-N4RT2	SZ-N4RT2	97.5	90	—	91.5	124*2	199	230	3
SZ-N6RT1	SZ-N6RT2	SZ-N6RT2	100	94.5	—	88	140	210	250	3
SZ-N7RT1	SZ-N7RT2	SZ-N7RT2	115	104	—	89	144	228	290	3
SZ-N8RT1	SZ-N8RT2	SZ-N8RT2	160	136	—	100	172	277	330	3
SZ-N11RT1	SZ-N11RT2	SZ-N11RT2	175	175	—	116	194	352	360	3

Note: \*1 134 for SC-N5, SW-N5 \*2 139 for SC-N5RM

■ **Mounting methods**

**SZ-N4T, SZ-WN4T**

**SZ-N6T to N11T,  
 SZ-WN6T to WN11T**

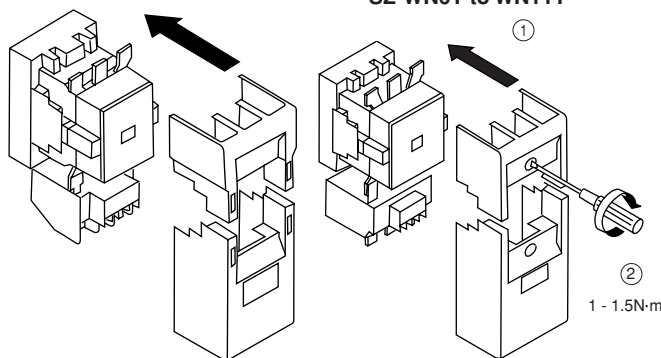

**Insulation barriers for SC-N4 to N12**

■ **Features**

These optional insulation barriers, prevent accidental short-circuits caused by metallic objects falling onto the terminals



SW-N6+SZ-B1

Description	Type	Used with
For contactor	SZ-B1	SC-N4, N5, N6, N7
	SZ-B2	SC-N8, N10, N11, N12
For starter	SZ-B1	SW-N4/3H, N5/3H, N6/3H, N7/3H
	SZ-B2	SW-N8/3H, N10/3H, N11/3H, N12/3H
For thermal overload relay	SZ-B1	TR-N6H, TK-N6H
	SZ-B2	TR-N10H, N12H, TK-N10H, N12H

■ **Dimensions, mm**

**SZ-B1**

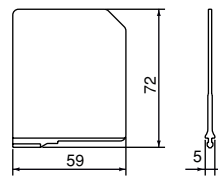

**SZ-B2**

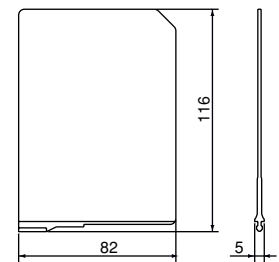

■ **Mounting methods**  
**Contactors**

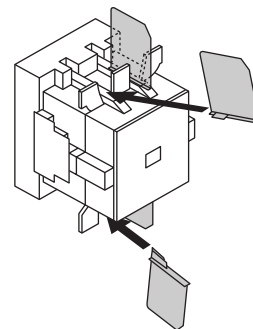

**Starters**

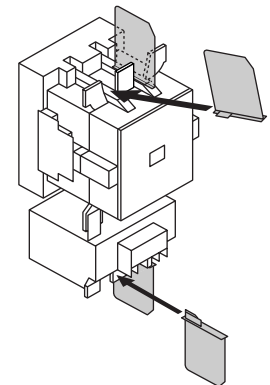

**Thermal overload relays**

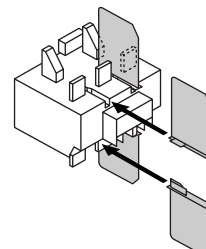

# Magnetic Contactors and Starters

## SC and SW series

### Optional unit

#### Live-section cover

The live-section cover completely encloses the front of a contactor or starter for increased worker safety during maintenance and inspection.

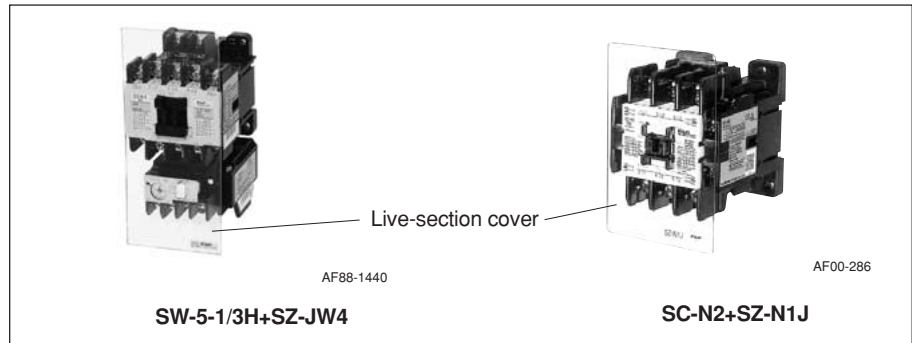

#### ■ Dimensions, mm

- Contactors
- Starters

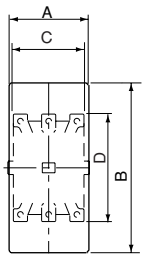

Fig. 1

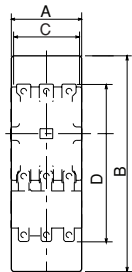

Fig. 2

- Starters (reversing)

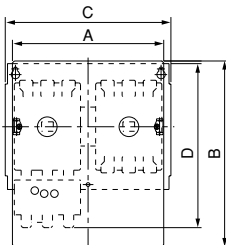
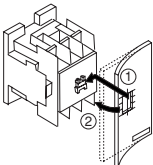

Fig. 3

#### ■ Mounting methods

SZ-JC1 to JC4, SZ-N1J, N2SJ,  
SZ-JW1 to JW4, SZ-WN1J, WN2SJ



SZ-N4J to N11J, SZ-WN4J to WN11J

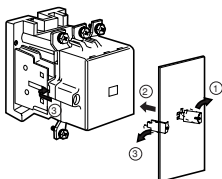

#### For contactor (Non-reversing)

Cover type	Contactor Type	Fig. No.	Live-section cover		Contactor	
			A	B	C	D
SZ-JC1	SC-03, 0	1	43	97	43	81
SZ-JC2	SC-05	1	53	97	53	81
SZ-JC3	SC-4-0, 4-1	1	53	100	53	81
SZ-JC4	SC-5-1	1	64	100	64	81
SZ-N1J	SC-N1, N2	1	74	120	74	87
SZ-N2SJ	SC-N2S, N3	1	88	140	88	110
SZ-N4J	SC-N4, N5	1	93	192	88	127
SZ-N6J	SC-N6	1	106	214	100	144
SZ-N7J	SC-N7	1	120	233	115	156
SZ-N8J	SC-N8, N10	1	138	265	138	209
SZ-N11J	SC-N11, N12	1	160	336	148	240

#### For starter (Non-reversing)

Cover type	Starter Type	Fig. No.	Live-section cover		Starter	
			A	B	C	D
SZ-JW1	SW-03/3H, 0/3H	2	44	140	44	122
SZ-JW2	SW-05/3H	2	53	140	53	122
SZ-JW3	SW-4-0/3H, 4-1/3H	2	53	145	53	127
SZ-JW4	SW-5-1/3H	2	64	145	64	127
SZ-WN1J	SW-N1/3H, N2/3H	2	74	175	74	146
SZ-WN2SJ	SW-N2S/3H, 3/3H	2	88	205	88	177
SZ-WN4J	SW-N4/3H, N5/3H	2	93	254	88	189
SZ-WN6J	SW-N6/3H	2	106	281	100	225
SZ-WN7J	SW-N7/3H	2	120	300	115	237
SZ-WN8J	SW-N8/3H	2	138	347	138	305
SZ-WN10J	SW-N10/3H	2	138	347	138	287
SZ-WN11J	SW-N11/3H, N12/3H	2	160	423	148	360

#### For starter (reversing)

Cover type	Starter Type	Fig. No.	Live-section cover		Starter	
			A	B	C	D
SZ-WN4RJ	SW-N4RM/3H, N5RM/3H	3	204	254	230	208
SZ-WN6RJ	SW-N6RM/3H	3	229	281	250	247.5
SZ-WN7RJ	SW-N7RM/3H	3	258	300	290	266
SZ-WN8RJ	SW-N8RM/3H	3	291	347	330	370
SZ-WN10RJ	SW-N10RM/3H	3	291	347	330	370
SZ-WN11RJ	SW-N11RM/3H, N12RM/3H	3	328	423	360	480

Note: Side mounting types with 4NO + 4NC auxiliary contacts are available. Add the suffix "/4" to the type number when ordering.

**2-pole DC magnetic contactors**

Up to 55kW 220 Volts DC  
Operational current up to 290 Amps  
220 Volts DC

■ **Description**

These highly efficient SB series DC magnetic contactors are improved versions of the SC-N series contactors. The magnetic assembly in these improved units is now the SUPER MAGNET so that these contactors will operate on both AC and DC power supplies and power consumption is minimized.

■ **Features**

- DC motor control  
5.5kW to 55kW (at 220V DC)
- Circuit voltage: Max. 550V DC  
Rated thermal current: Max. 360A
- A special magnetic blow-out device ensures improved interrupting performance.
- The main contact arrangement is 2NO. 2NO+1NC types are also available. The 1NC is used for Dynamic Brake circuits.

■ **Ordering code system**

S B 3 5 B A A — 02 E 2 2  
① ② ③ ④ ⑤ ⑥ ⑦ ⑧ ⑨ ⑩ ⑪

① **Product category**

Description	Code
Contactor and starter	S

② **Series category**

Description	Code
SB series	B

③④ **Frame size**

Frame size	Code	
	③	④
2N	3	5
5N	8	5
6N	1	C
10N	2	A
11N	2	K

⑤ **Version**

Description	Code
<u>Non-reversing, open</u> Standard	B
UL approved	1

⑥ **Coil specification**

Description	Code
Standard	AC operating coil Both AC and DC operating coil
With SUPER MAGNET	Both AC and DC operating coil



- The SUPER MAGNET system permits these contactors to operate on both AC and DC power supplies\*.
- Auxiliary contacts can be supplied up to 4NO+4NC arrangement (2NO+2NC for standard products).

Note: \* The SB-2N (2NB) operates only on AC. The SB-2N/SE (2NB/SE) is provided with a SUPER MAGNET and operates on both AC and DC power supplies.

JEM 1038

- DC2: For shunt-wound motors:  
Starting, switching off during running.  
The starting current is less than 2.5 times the rated current.
- DC4: For series-wound motors:  
Starting, switching off during running.  
The starting current is less than 2.5 times the rated current.

⑦ **Main contact**

Contact arrangement	Code
2NO	A
2NO + 1NC	B

⑧ **Special main contact (for SB35□□B-)**

Main contact	Code
2NC	02
1NO + 2NC	12

⑩⑪ **Auxiliary contact**

Contact arrangement	Code	
	⑨	⑩
2NO + 2NC	2	2
3NO + 3NC	3	3
4NO + 4NC	4	4

⑨ **Coil voltage**  
● **AC coil/SB-2N**

Operating coil voltage		Code
50Hz	60Hz	
24V	24 — 26V	E
48V	48 — 52V	C
100V	100 — 110V	1
100 — 110V	110 — 120V	H
110 — 120V	120 — 130V	K
200V	200 — 220V	2
200 — 220V	220 — 240V	M
220 — 240V	240 — 260V	P
346 — 380V	380 — 420V	S
380 — 400V	400 — 440V	4
415 — 440V	440 — 480V	T
480 — 500V	500 — 550V	5

● **AC and DC coil/SB-2N/SE, 5N to 11N**

Operating coil voltage		Code
AC 50/60Hz	DC	
24 — 25V	24V	E
48 — 50V	48V	F
100 — 127V	110 — 110V	1
200 — 250V	200 — 220V	2
265 — 347V	—	3
380 — 450V	—	4
460 — 575V	—	5

# DC Magnetic Contactors

## SB series

### Types and ratings

Max. motor capacity (kW)			Rated operational current (A)			Rated thermal current (A)	Auxiliary contact		With 2NO main contacts		With 2NO+1NC* main contacts	
110V	220V	440V	110V	220V	440V		NO	NC	Type	Ordering code	Type	Ordering code
3.7	5.5	7.5	40	35	25	60	2	2	<b>SB-2N</b>	SB35BAA-■22	<b>SB-2NB</b>	SB35BAB-21■22
3.7	5.5	7.5	40	35	25	60	2	2	<b>SB-2N/SE</b>	SB35BSA-■22	<b>SB-2NB/SE</b>	SB35BSB-21■22
7.5	15	22	85	85	60	120	2	2	<b>SB-5N</b>	SB85BBA-■22	<b>SB-5NB</b>	SB85BBB-■22
11	22	30	125	120	80	160	2	2	<b>SB-6N</b>	SB1CBBA-■22	<b>SB-6NB</b>	SB1CBBB-■22
22	37	45	240	200	120	270	2	2	<b>SB-10N</b>	SB2ABBA-■22	<b>SB-10NB</b>	SB2ABBB-■22
30	55	75	320	290	200	360	2	2	<b>SB-11N</b>	SB2KBBA-■22	<b>SB-11NB</b>	SB2KBBB-■22

Notes: • Conforming to class DC2 and DC4, JEM 1038  
 • Auxiliary contact 4NO+4NC is available on request.  
 \* For SB-2NB and SB-2NB/SE, 2NC or 1NO+2NC main contacts are also available.  
 ■: Coil voltage code

### Auxiliary contact

Type	Rated thermal current (A)	Making and breaking current (AC, A)	Rated operational current (A)					
			AC circuit			DC circuit		
			Volts	AC-15 (ind.)	AC-12 (res.)	Volts	DC-13 (ind.)	DC-12 (res.)
<b>SB-2N to 11N</b> <b>SB-2NB to 11NB</b>	10	60	110V	6	10	24V	10	10
			220V	6	10	48V	3	5
			440V	4	10	110V	1.5	2.5
			550V	2.5	10	220V	0.5	1

Note: For DC-13 (inductive load) time constant is 100ms or less.

### NC contact ratings

Type	Rated thermal current (A)	Dynamic brake*		
		Making current (A)	Operating cycles per hour	Time rating (sec)
<b>SB-2NB</b>	50	60	600	3
<b>SB-2NB/SE</b>	50	60		
<b>SB-5NB</b>	100	130		
<b>SB-6NB</b>	100	190		
<b>SB-10NB</b>	160	360		
<b>SB-11NB</b>	200	480		

Note: \* Braking condition: No voltage

### Performance data NO contacts (2-pole in series)

Frame size	Making and braking capacity	Operating cycles per hour	Life expectancy (operations)	
			Electrical	Mechanical
<b>SB-2N to 11N</b> <b>SB-2N/SE</b> <b>SB-2NB to 11NB</b> <b>SB-2NB/SE</b>	4 × le	1200	500,000	2.5 million

le: Rated operational current

### Coil ratings

Type	Coil voltage and frequency	Code
<b>2N</b>	100V 50Hz/100 to 110V 60Hz	1
	200V 50Hz/200 to 220V 60Hz	2
	380 to 400V 50Hz/400 to 440V 60Hz	4

Notes: • The standard voltages are 100V, 200V, and 400V.  
 • Voltage ranging from 24V to 550V are also available on request.

Type	Coil voltage and frequency		Code
	AC	DC	
<b>2N/SE</b>	24 to 25V 50/60Hz	24V	E
<b>5N</b>	48 to 50V 50/60Hz	48V	F
<b>6N</b>	100 to 127V 50/60Hz	100 to 110V	1
<b>10N</b>	200 to 250V 50/60Hz	200 to 220V	2
<b>11N</b>	265 to 347V 50/60Hz	—	3
	380 to 450V 50/60Hz	—	4
	460 to 575V 50/60Hz	—	5

Notes: • The coils can be used for both AC and DC input.  
 • The standard voltages are 100V, 200V, and 400V.  
 Other voltages are available on request in following range.  
 Frame size 2N/SE: 24 to 250V 5N to 10N: 24V to 575V  
 11N: 100 to 575V

■ Dimensions, mm  
SB-2N, SB-2NB

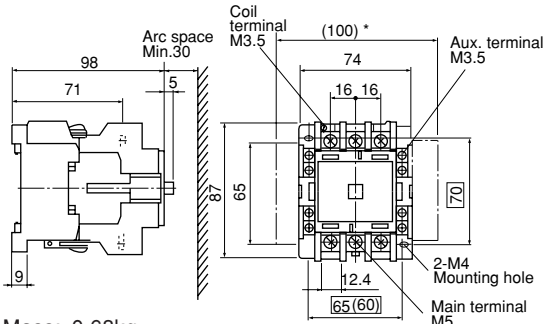

Mass: 0.68kg

SB-5N, SB-5NB, SB-8N, SB-6NB

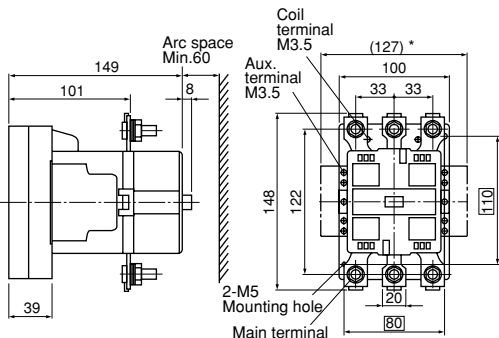

Mass: 2.5kg

SB-11N, SB-11NB

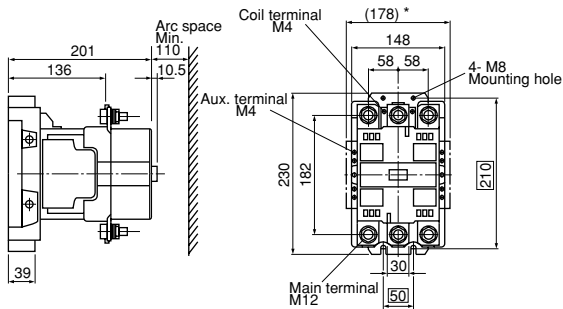

Mass: 6.7kg

■ Wiring diagrams  
Main contact  
2NO

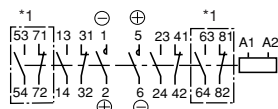

Main contact  
2NO+1NC

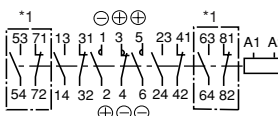

\*1 In case of auxiliary contact 4NO+4NC

■ Ordering information

Specify the following:

1. Type number or ordering code

SB-2N/SE, SB-2NB/SE

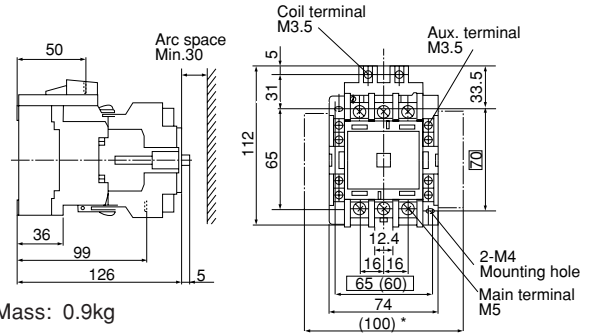

Mass: 0.9kg

SB-10N, SB-10NB

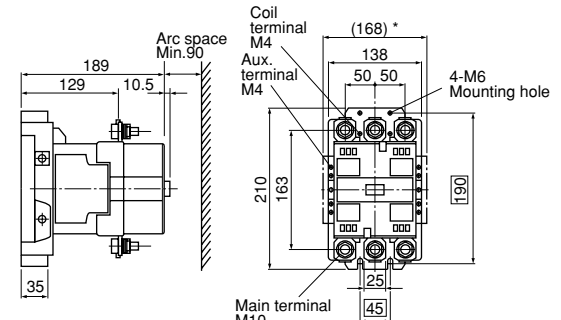

Mass: 5.2kg

Note: \* For two side-mounted aux.contact blocks

■ Handling notes

1. The main contacts are marked for positive and negative polarities. Do not confuse the polarities when connecting.
2. Be sure to install the contactors upright.
3. Allow adequate arcing space.

(-) (+)

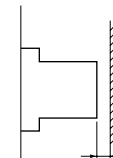
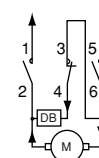

Arc space, mm	
2N, 2N/SE:	30
5N, 6N :	60
10N :	90
11N :	110

Min. arc space

# Magnetic Contactors and Starters

## FC and FW series

### Magnetic contactors FC series

#### ■ Description

FUJI FC series contactors are designed for use in consumer products and light industrial machinery and equipment. They are recommended for applications which call for economy, easy handling and reliability. Typical applications include air conditioners, show cases, industrial washing machines, heaters, pumps, fans, compressors, dryers and vending machines. They are available in sizes ranging from FC-0UL to 4UL and up to 30kW at 440 Volts AC.

#### ■ Features

- Small size, light weight
- Budget priced
- Long service life  
Electrical life expectancy: 250,000 operations. Good for 7 years service if they are operated 100 times a day.
- Scrubbing action  
The contacts are self-cleaning by a scrubbing action during operation and are made of a silver alloy.
- Highly reliable operating coil  
Pick-up voltage  
75% of rated voltage
- Self-lifting terminals  
Easy to wire

#### ■ Construction

##### FC-0UL, 0SUL

- Their small size permits them to be mounted in positions where space is limited and they can be mounted in a variety of directions.
- The standard terminals are screw-type. Printed board type and tab terminals are also available.

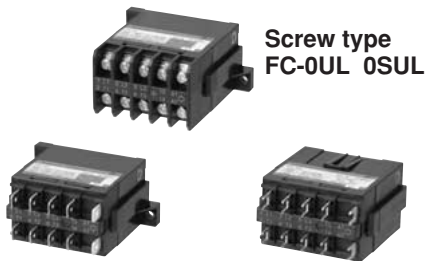

Tab terminal type FC-0TUL      Printed board type FC-0A

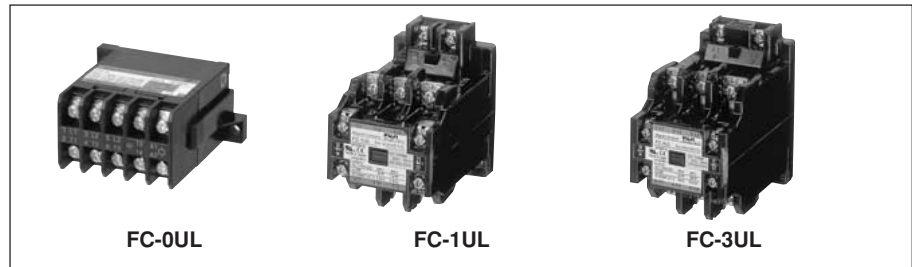

- The contact section is housed inside the molded frame and is totally enclosed. The dust-tight construction keeps contact performance at a high level and results in a long trouble-free service life.

#### FC-1UL to 4UL

- FUJI self-lifting terminals make connection work simple.
- Their free floating design results in quiet operation and eliminates chattering and bouncing.
- The magnetic yokes have been given a rust preventing treatment.
- Coil power consumption is low.

#### ■ Ordering information

Specify the following:

1. Ordering code
2. Operating coil voltage code
3. Auxiliary contact arrangement:  
In the case of type FC-0UL, 0A and 0TUL, specify the contact arrangement.

#### ■ Types and ratings (IEC60947-4-1)

Motor capacity (kW) AC-3 3-phase		Operational current (A) AC-3 3-phase		Operational current (A) AC-1 *2	Auxiliary contact		Non-reversing Open	
200V	380V	200V	380V		NO	NC	Type	Ordering code
3	2.5	12	6	20	1	—	FC-0UL	SF12B1A-■10
3	2.5	12	6	20	—	1	FC-0UL	SF12B1A-■01
3.5	4.5	15	10	20	1	—	FC-0SUL	SF15B1A-■10
3.5	4.5	15	10	20	—	1	FC-0SUL	SF15B1A-■01
5.5	5.5	20	13	30	1	1*1	FC-1UL	SF20B1A-■11
7.5	7.5	27	18	30	1	1*1	FC-1SUL	SF26B1A-■11
11	11	40	26	45	1	1*1	FC-2SUL	SF38B1A-■11
15	18.5	52	40	60	1	1*1	FC-3UL	SF50B1A-■11
18.5	30	65	65	80	1	1*1	FC-4UL	SF65B1A-■11
1.5	—	8	—	8	1	—	FC-0A	SF08BBA-■10
1.5	—	8	—	8	—	1	FC-0A	SF08BBA-■01
3	2.5	12	6	20	1	—	FC-0TUL	SF12B3A-■10
3	2.5	12	6	20	—	1	FC-0TUL	SF12B3A-■01
3.5	4.5	15	10	20	1	—	FC-0STUL	SF15B3A-■10
3.5	4.5	15	10	20	—	1	FC-0STUL	SF15B3A-■01
3	2.5	12	6	20	1	—	FC-0/GUL	SF12B1G-■10
3	2.5	12	6	20	—	1	FC-0/GUL	SF12B1G-■01
3.5	4.5	15	10	20	1	—	FC-0S/GUL	SF15B1G-■10
3.5	4.5	15	10	20	—	1	FC-0S/GUL	SF15B1G-■01
3	2.5	12	6	20	1	—	FC-0T/GUL	SF12B3G-■10
3	2.5	12	6	20	—	1	FC-0T/GUL	SF12B3G-■01
3.5	4.5	15	10	20	1	—	FC-0ST/GUL	SF15B3G-■10
3.5	4.5	15	10	20	—	1	FC-0ST/GUL	SF15B3G-■01
1.5	—	8	—	8	1	—	FC-0A/G	SF08BBG-■10
1.5	—	8	—	8	—	1	FC-0A/G	SF08BBG-■01

Notes: \*1 Auxiliary contact arrangement 2NO or 2NC is available.

Cable connection: FC-0A: P. C. board  
FC-0TUL, 0STUL: With flat connection tabs  
Other types: With screw-type terminals

\*2 Thermal current (A)

■: Coil voltage code, see page 01/91.

■ Ordering code system

● Contactor

S F 3 5 B 1 A — E 2 2  
① ② ③ ④ ⑤ ⑥ ⑧ ⑨ ⑩

① Product category

Description	Code
Contactors and starters	S

② Series category

Description	Code
F series	F

③④ Frame size

Frame size	Code	
	③	④
0, 0T	1	2
0A	0	8
0S, 0ST	1	5
1	2	0
1S	2	6
2S	3	5
3	5	0
4	6	5

⑤ Version

Description	Code
<u>Non-reversing, open</u>	
Contactors	1
Standard	T
With tab terminal	
Starters	A
Standard	
<u>Non-reversing, enclosed</u>	
Standard	C
With ON-OFF pushbutton (plastic enclosure)	P
With ON-OFF pushbutton (steel enclosure)	S
With ON-OFF pushbutton and lamp (plastic enclosure)	K

⑥ Coil specification

Description	Code
AC operating coil	A
DC operating coil	G

⑦ Type of thermal overload relay

Description	No. of element	Code
Standard	2, 3	N
Quick operating	3	S
Open-phase protection	3	E

● Starter

S F 3 5 B A A N — E 2 2 T B D  
① ② ③ ④ ⑤ ⑥ ⑦ ⑧ ⑨ ⑩ ⑪ ⑫

⑧ Coil voltage

Operating coil voltage		Code
50Hz	60Hz	
24V	24 — 26V	E
48V	48 — 52V	F
100V	100 — 110V	1
100 — 110V	110 — 120V	H
110 — 120V	120 — 130V	K
200V	200 — 220V	2
200 — 220V	220 — 240V	M
220 — 240V	240 — 260V	P
346 — 380V	380 — 420V	S
380 — 400V	400 — 440V	4
415 — 440V	440 — 480V	T

● DC coil

Operating coil voltage	Code
24V DC	E
48V DC	F
60V DC	G
100V DC	1
110V DC	H
200V DC	2
220V DC	M

⑩ Thermal overload relay ampere setting range

Ampere setting range (A)	Code	Ampere setting range (A)	Code	Ampere setting range (A)	Code
0.1 — 0.15	TA	1.4 — 2.2	TM	7 — 11	TV
0.15 — 0.24	TC	1.7 — 2.6	TN	8 — 16	TV
0.24 — 0.36	TE	2.2 — 3.4	TP	9 — 13	TW
0.36 — 0.54	TG			12 — 18	TX
				13 — 20	TA*1
				18 — 26	TB
				20 — 26	TC*2
0.48 — 0.72	TH	2.8 — 4.2	TR	24 — 36	TE
0.64 — 0.96	TJ	4 — 6	TS	28 — 40	TF
0.8 — 1.2	TK	5 — 8	TT	34 — 50	TG
0.95 — 1.45	TL	6 — 9	TU	45 — 67	TJ

Note: \*1 For FW-1S: X

\*2 For FW-1S: Y

⑫ No. of heater element

Description	Code
2-element	Blank
3-element	D

# Magnetic Contactors and Starters

## FC and FW series

### ■ Auxiliary contact ratings (IEC 60947-4-1)

Frame size	Rated thermal current (A)	Voltage (V AC)	Making & breaking capacity (A)	Rated operational current (A)	
				Inductive	Resistive
0, 0A, 0T 0S	8	110	40	4	8
		220	40	4	8
		440	20	2	8
1, 1S, 2S 3, 4	10	110	100	10	10
		220	60	6	10
		440	60	6	10

### ■ Performance data

Frame size	Making capacity (A)	Breaking capacity (A)	Operating cycles per hour	Life expectancy (operations)	
				Electrical	Mechanical
0 to 1S	10 × Ie	10 × Ie	600	250,000	1 million
2S to 4	10 × Ie	10 × Ie	600	250,000	1 million

Ie: Rated operational current

### ■ Coil ratings

Frame size	Power consumption		Voltage and frequency *	Wiring	Operating voltage range
	Inrush (VA)	Sealed (VA)			
0, 0A, 0T, 0S	23	6	200V	A	0.75 to
1, 1S	75	11	50Hz		1.1 times
2S	125	14			rated coil
3	125	14			voltage
4	200	14.3			

Notes: \* Other voltages between 24V and 440V AC are available.  
DC operated type FC-0/G and FC-0T/G are also available.  
Coil voltage: 24, 48, 60, 100, 120, 200, 210 and 220V DC

### FC-2SUL, 3UL

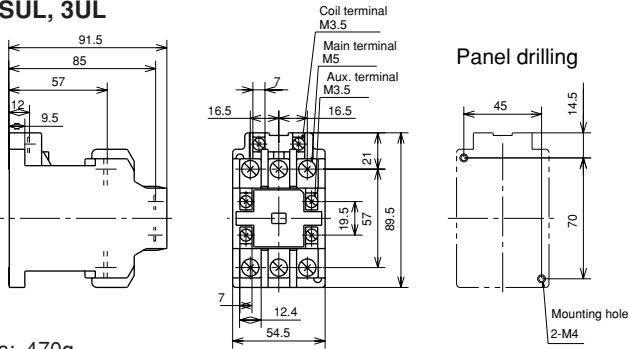

Mass: 470g

### FC-4UL

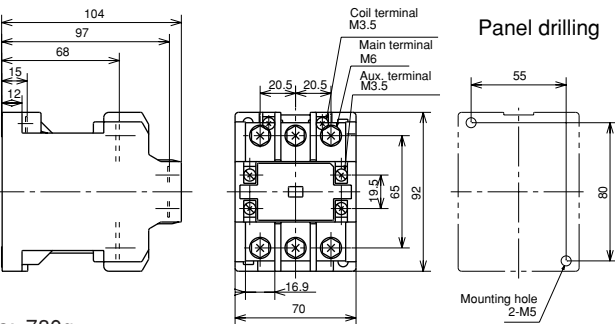

Mass: 780g

### ■ Wiring diagrams

#### FC-0UL, 0A, 0TUL, 0SUL, 0STUL

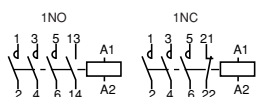

#### FC-1UL, 1SUL, 2SUL, 3UL, 4UL

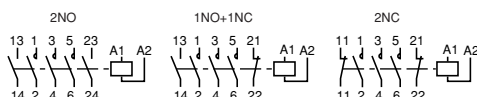

### ■ Dimensions, mm

#### FC-0UL, 0SUL

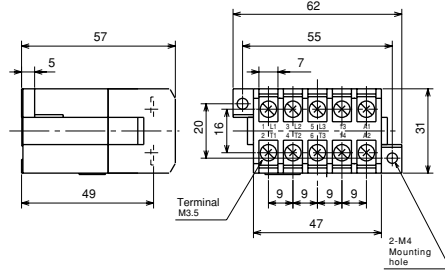

Mass: 160g

#### FC-0TUL, 0ST/UL

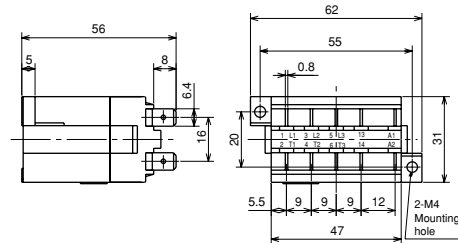

Mass: 160g

#### FC-0A

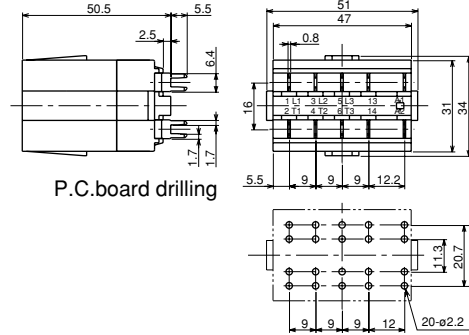

Mass: 140g

#### FC-1UL, 1SUL

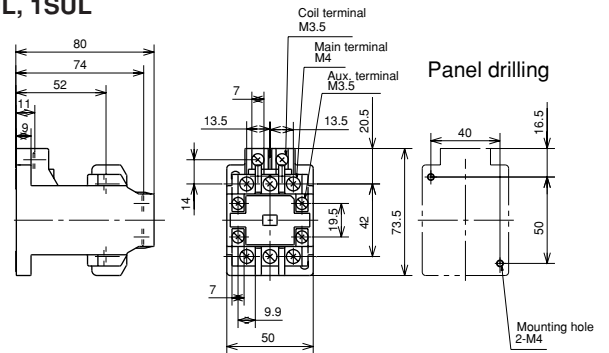

Mass: 320g



**Non-reversing motor starters  
FW series**

Up to 30kW 440 Volts 3-phase

**Description**

The FUJI FW-series starters are primarily designed for domestic and light industrial use, and can be expected to have a service life of over seven years under conditions where they are operated over 100 times a day. Typical applications are air conditioners, industrial washing machines, boiler and other pumps, fans, compressors, dryers.

The FC contactor can be supplied separately. They are simple, compact and reasonably priced, yet highly efficient and dependable. The thermal overload relay is fitted with elements that compensate for changes in ambient temperature, so stabilizing operations in spite of the season.

Note: In case of F series, contacts and operating coil cannot be replaced at site.

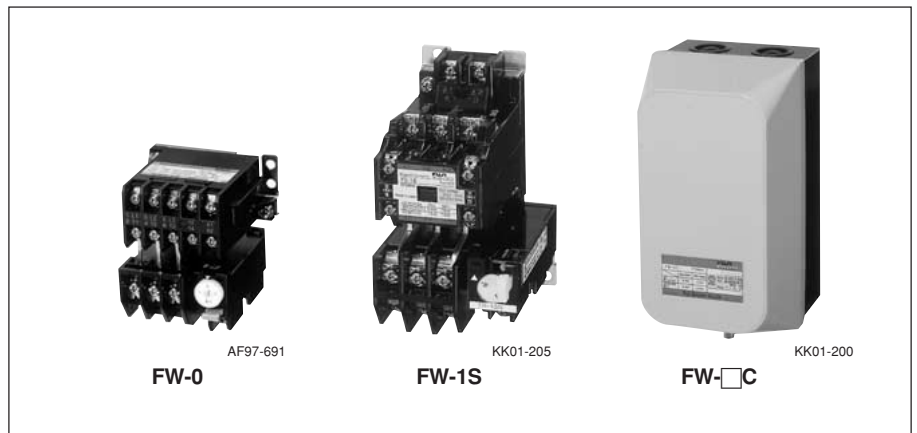

**Ordering information**

Specify the following:

1. Ordering code
2. Operating coil voltage code
3. Overload relay setting range code

**Thermal overload relay:**

See page 01/95.

**Types and ratings**

Motor capacity (kW)		Operational current (A)		Aux. contact		Open		Enclosed		Combined thermal overload relay
3-phase		3-phase				3-element		3-element		Type
200V	380V	200V	380V	NO	NC	Type	Ordering code	Type	Ordering code	
3	2.5	12	6	1	—*1	<b>FW-0/3H</b>	SF12BAAN-■10T□□	<b>FW-0C/3H</b>	SF12BCAN-■10T□□	TR-0/3
3.5	4.5	15	10	1	—*1	<b>FW-0S/3H</b>	SF15BAAN-■10T□□	<b>FW-0SC/3H</b>	SF15BCAN-■10T□□	TR-0/3
5.5	5.5	20	13	1	1*2	<b>FW-1/3H</b>	SF20BAAN-■11T□□	<b>FW-1C/3H</b>	SF20BCAN-■11T□□	RCa3737-1CNF/3
7.5	7.5	27	18	1	1*2	<b>FW-1S/3H</b>	SF26BAAN-■11T□□	<b>FW-1SC/3H</b>	SF26BCAN-■11T□□	TR-1SN/3
11	11	40	26	1	1*2	<b>FW-2S/3H</b>	SF35BAAN-■11T□□	<b>FW-2SC/3H</b>	SF35BCAN-■11T□□	TR-2NF/3
15	18.5	52	40	1	1*2	<b>FW-3/3H</b>	SF50BAAN-■11T□□	<b>FW-3C/3H</b>	SF50BCAN-■11T□□	TR-2NF/3
18.5	30	65	65	1	1*2	<b>FW-4/3H</b>	SF65BAAN-■11T□□	<b>FW-4C/3H</b>	SF65BCAN-■11T□□	TR-3N/3

Notes: \*1 Auxiliary contact arrangement 1NC is available.  
\*2 Auxiliary contact arrangement 2NO or 2NC is available.  
Conforming to IEC 60947-4-1 AC-3.

■: Coil voltage code, see page 01/91.  
□: Thermal overload relay ampere setting range code, see page 01/91.

**Coil ratings**

Frame size	Power consumption (max.)		Voltage and frequency *
	Inrush (VA)	Sealed (VA)	
<b>0, 0S</b>	23	6	200V AC 50Hz
<b>1, 1S</b>	75	11	
<b>2S</b>	125	14	
<b>3</b>	125	14	
<b>4</b>	200	14.3	

Notes: \* Other voltages between 24V and 440V AC are available.  
DC operated type FC-0/G and FC-0T/G are also available.  
Coil voltage: 24, 48, 60, 100, 120, 200, 210 and 220V DC

**Wiring example**

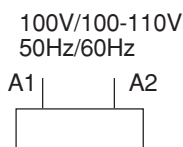

**Performance data**

Frame size	Making & breaking capacity	Operating cycles per hour	Durability (operations)	
			Electrical	Mechanical
<b>0, 0S, 1, 1S</b>	10 × Ie	600	250,000	1,000,000
<b>2S, 3, 4</b>	10 × Ie	600	250,000	1,000,000

Ie: Rated operational current (Amps).

**Auxiliary contact ratings**

Frame size	Rated thermal current (A)	Voltage (V AC)	Making & breaking capacity (A)	Rated operational current A)	
				Inductive (cosφ=0.65)	Resistive (cosφ=0.95)
<b>0, 0S</b>	8	200-240	40	4	8
		380-440	20	2	8
<b>1, 1S, 2S</b>	10	200-240	60	6	10
		380-440	60	6	10

# Magnetic Contactors and Starters

## FC and FW series

■ Dimensions, mm  
● Open type  
FW-0/3H, FW-0S/3H

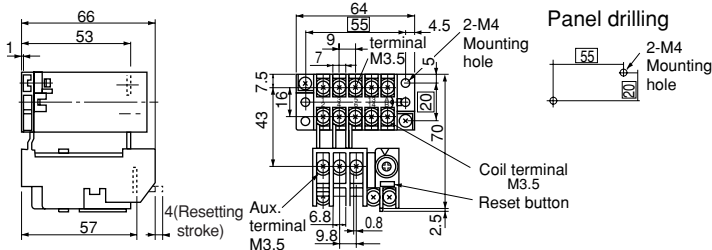

Mass: 0.29kg (with 3-thermal element)

● Enclosed type  
FW-0C, 0SC, 1C

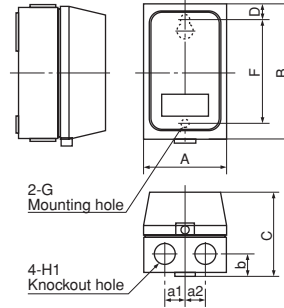

FW-1/3H, FW-1S/3H, 2S/3H, 3/3H, 4/3H

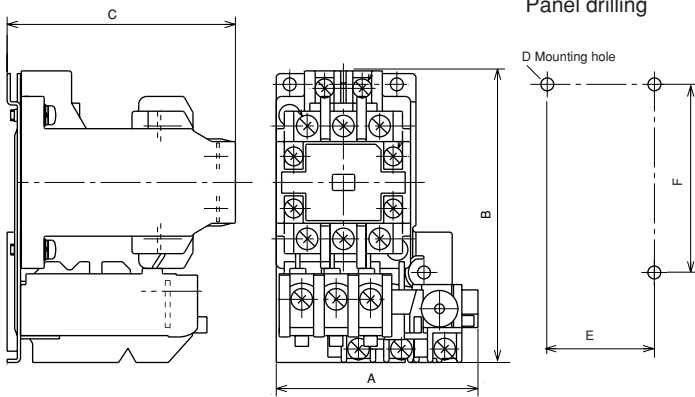

Type	A	B	C	D	E	F	Mass (kg)
FW-1/3H	75	108.5	85	2-M4	50	70	0.49
FW-1S/3H	68	121	90	2-M4	40	110	0.55
FW-2S/3H	78	138.5	91.5	2-M4	45	70	0.71
FW-3/3H	78	138.5	91.5	2-M4	45	70	0.71
FW-4/3H	90	175	109	3-M5	75	160	1.3

Mass: With 3-thermal element

Dimensions for reference only. Confirm before construction begins.

FW-1SC, 2SC, 3C, 4C

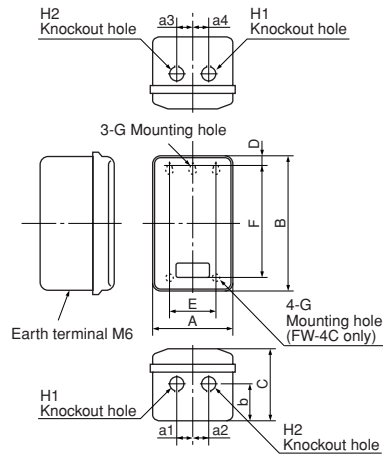

Type	A	B	C	D	E	F	G
FW-0C, 0SC*	71	120	79	15	-	90	ø5.3
FW-1C	94	166	95	15.5	-	135	ø5.5
FW-1SC	120	195	115	21.5	80	150	ø7
FW-2SC, 3C	130	230	124	20	80	190	ø7
FW-4C	175	320	145	35	110	250	ø7

Type	H1	H2	a1	a2	a3	a4	b	Mass(kg)
FW-0C, 0SC*	ø17	-	17.5	17.5	17.5	17.5	20	0.25
FW-1C	ø22	-	20	20	20	20	24	0.7
FW-1SC	ø22	ø22	22.5	22.5	20	20	35	1.5
FW-2SC, 3C	ø28	ø28	27	27	20	20	52	2
FW-4C	ø35	ø28	15	35	35	15	70	3.7

Note: \* The enclosure dimensions given here are based on a "TR-0 thermal overload relay and 2-elements" being incorporated in the case. The temperature rise inside the enclosure may sometimes become a problem if a 3-element is used instead of a 2-element. In this case the FW-0P (Enclosure with pushbuttons) is recommended.

■ Wiring diagrams  
FW-0/3H, 0S/3H

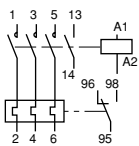

FW-1S/3H to 4/3H

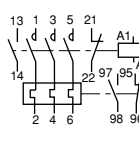

FW-1/3H

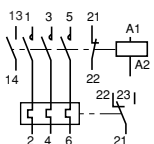

Example  
FW-2S/3H

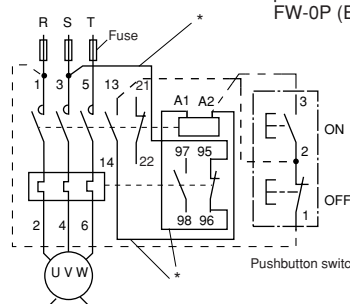

Note: \* Open type: Wirings from 3 to 95, A2 to 14 and A1 to 96 are not connected at factory. Connect the wires at site.

**Thermal overload relays for FW series**

Type*1 (3-element)	Setting current (3-element)*1				Reset	Contact
	Range (A)	Ordering code	Range (A)	Ordering code		
<b>TR-0/3</b>	0.24-0.36	TB13DW-E	4-6	TB13DW-S	Manual *2	SPDT
	0.48-0.72	TB13DW-H	5-8	TB13DW-T		
	0.8-1.2	TB13DW-K	6-9	TB13DW-U		
	0.95-1.45	TB13DW-L	7-11	TB13DW-V		
	1.4-2.2	TB13DW-M	9-13	TB13DW-W		
	1.7-2.6	TB13DW-N				
	2.8-4.2	TB13DW-R				
<b>RCa3737-1CNF/3</b>	4-8	TC20DF-S			Manual	
	8-16	TC20DF-V				
	12-18	TC20DF-X				
<b>TR-1SN/3</b>	13-20	TR26DW-X			Manual and auto	1NO+1NC
	20-26	TR26DW-Y				
<b>TR-2NF/3</b>	12-18	TR35DW-X	28-40	TR35DW-F	Manual and auto	
	18-26	TR35DW-B	34-50	TR35DW-G		
	24-36	TR35DW-E				
<b>TR-3N/3</b>	24-36	TR65DW-E	34-50	TR65DW-G	Manual and auto	
	28-40	TR65DW-F	45-67	TR65DW-J		

Notes: \*1 2-element is also available on request.  
\*2 Auto reset type is available on request. Specify "Auto reset" when ordering.

**Maximum setting ranges at 380-440V AC for starter use**

<b>TR-0/3</b>	4-6A	<b>TR-2N/3</b>	18-26A (for FW-2S/3H)
<b>RCa3737-1CNF/3</b>	8-16A		34-50A (for FW-3/3H)
<b>TR-1SN/3</b>	13-20A	<b>TR-3N/3</b>	45-67A (for FW-4/3H)

■ Characteristic curves (Cold start)

**TR-0/3**

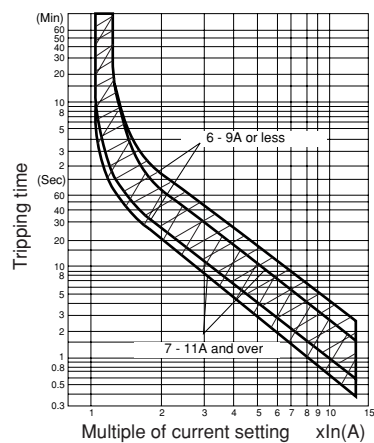

**RCa3737-1CNF/3**

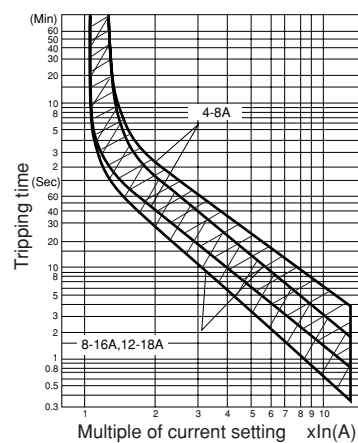

**TR-1SN/3**

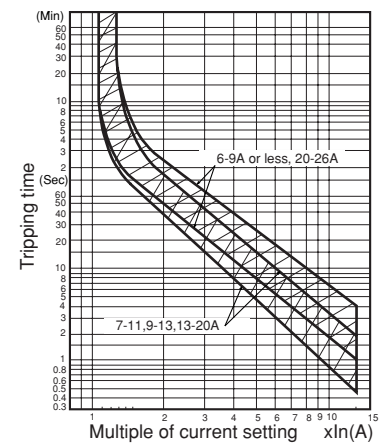

**TR-2NF/3**

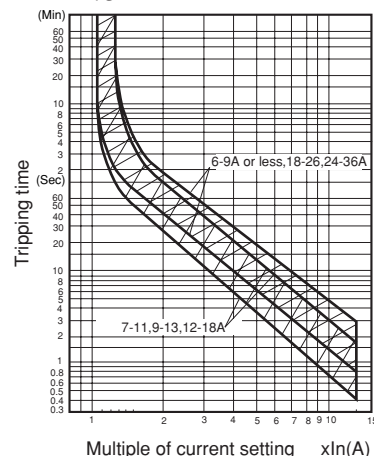

**TR-3N/3**

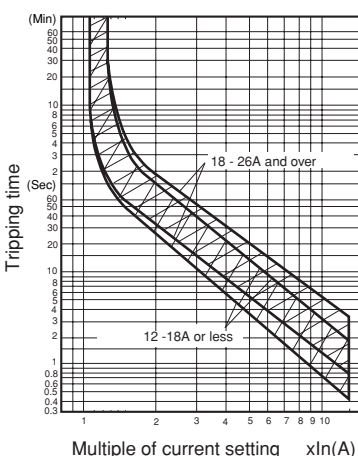

# Magnetic Contactors and Starters

## FW series

### With pushbuttons

#### Magnetic motor starters with pushbuttons

Up to 4.5kW 440 Volts 3-phase

##### ■ Description

FW series magnetic motor starter is provided with square-shaped ON-OFF pushbuttons. Internal wirings are connected. The starter is housed in a plastic enclosure (FW-0P/3H) or steel enclosure (FW-0PB/3H, 1PB/3H). The two operating buttons are color-coded; green for ON and red for OFF. Thermal overload relay is fitted with 2 or 3-element and is of manual reset type.

##### ■ Ordering information

Specify the following:

1. Ordering code
2. Operating coil voltage
3. Main circuit voltage.
4. Overload relay setting range code

[See page 01/95.](#)

##### ■ Performance data

Same as FW series. [See page 01/93.](#)

##### ■ Characteristic curves (Cold start)

[See page 01/95.](#)

##### ■ Thermal overload relay

Type	Setting range (A)	Contact	Starter type
<b>TR-0</b> (2 or 3-element)	0.24–0.36, 0.48–0.72, 0.8–1.2, 0.95–1.45 1.4–2.2, 1.7–2.6, 2.8–4.2, 4–6, 5–8, 6–9 7–11, 9–13	SPDT 95 — 96 — 98	FW-0P, FW-0P/3H, FW-0PL, FW-0PL/3H, FW-0SP, FW-0SP/3H FW-0PB, FW-0PB/3H, FW-0SPB, FW-0SPB/3H
<b>RCa3737-1CNF</b> (2 or 3-element)	4–8, 8–16, 12–18	SPDT 21 — 22 — 23	FW-1PB, FW-1PB/3H

Note: Maximum setting ranges at 440V AC for starter use:

TR-0: 4-6A, RCa3737-1CNF: 8-16A

##### ■ Dimensions, mm

###### FW-0P, 0PL, 0SP, 0SPL

Plastic enclosure

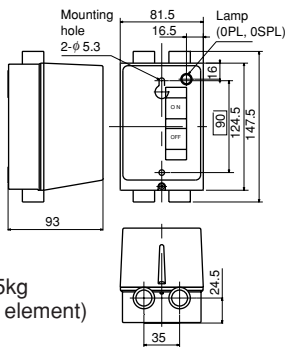

Mass: 0.45kg  
(3-thermal element)

###### FW-0PB, 0SPB

Steel enclosure

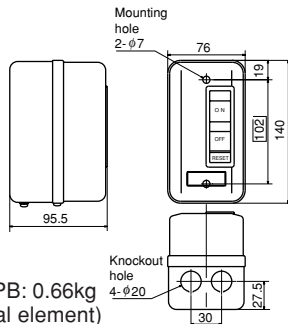

Mass: 0PB: 0.66kg  
(3-thermal element)

###### FW-1PB

Steel enclosure

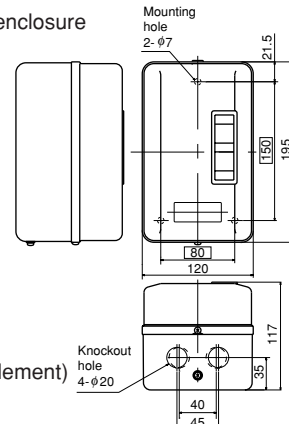

Mass: 1.5kg  
(3-thermal element)

##### ■ Wiring diagrams

###### FW-0P/3H, 0PL/3H, 0SP/3H, 0SPL/3H

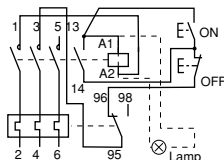

###### FW-0PB/3H, 0SPB/3H

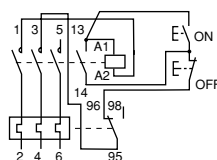

###### FW-1PB/3H

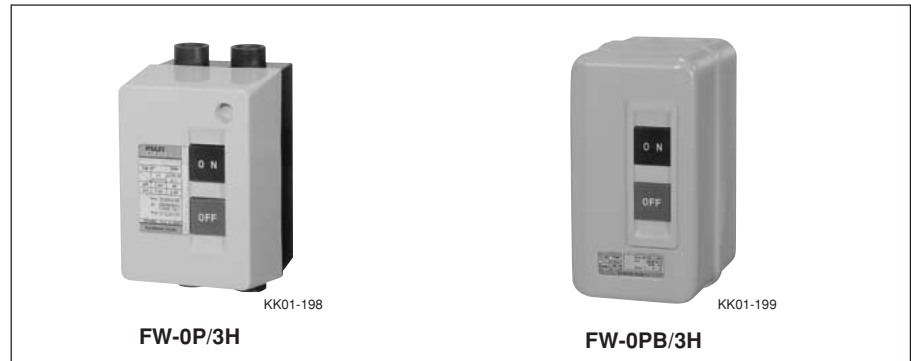
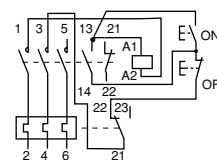

##### ■ Types and ratings

Max. motor capacity (kW)		Operational current (A)		2-thermal element		3-thermal element	
3-phase		200-240V		Type	Ordering code	Type	Ordering code
3.0	2.5	12	6	<b>FW-0P</b>	SF12BPAN-10T□	<b>FW-0P/3H</b>	SF12BPAN-10T□D
3.5	4.5	15	10	<b>FW-0SP</b>	SF15BPAN-10T□	<b>FW-0SP/3H</b>	SF15BPAN-10T□D
3.0	2.5	12	6	<b>FW-0PB</b>	SF12BSAN-10T□	<b>FW-0PB/3H</b>	SF12BSAN-10T□D
3.5	4.5	15	10	<b>FW-0SPB</b>	SF15BSAN-10T□	<b>FW-0SPB/3H</b>	SF15BSAN-10T□D
5.5	5.5	20	13	<b>FW-1PB</b>	SF20BSAN-11T□	<b>FW-1PB/3H</b>	SF20BSAN-11T□D
3.0	2.5	12	6	<b>FW-0PL</b>	SF12BKAN-10T□	<b>FW-0PL/3H</b>	SF12BKAN-10T□D
3.5	4.5	15	10	<b>FW-0SPL</b>	SF15BKAN-10T□	<b>FW-0SPL/3H</b>	SF15BKAN-10T□D

Notes: Auxiliary contact 1NC is available on request. (0P, 0PB)

Conforming to IEC 60947-4-1 AC-3.

■: Enter the operating coil voltage code.

□: Enter the thermal overload relay ampere setting range code.

**Standard type thermal overload relays**

■ **Description**

- Highly reliable thermal overload relays
- FUJI thermal overload relays are designed to provide overload protection to meet the thermal characteristics of low voltage induction motors. Adjustable thermal overload relays give motors positive overcurrent protection. The starter contacts cannot be held closing under overload conditions. However, once the bimetal element has cooled, the reset button can be depressed and the motor can be restarted in the normal manner. Ordinarily this reset is carried out manually but the starter can be changed over to 'automatic reset' by means of a screw-driver.
- FUJI thermal overload relay is subjected to stringent testing in the factory to check performance and actual values are calibrated with the markings on the adjustable dial. Consequently, they provide a positive protection.
  - Relays are also provided with ambient temperature compensators, so that their performance will be maintained in spite of temperature changes. The ambient temperature is regulated for 20°C.
  - The heater elements are available for either 2- or 3-pole use.

**Long time operating type**

In the case of loads having large inertia moments such as blowers, winders or centrifuges the starting time is extended. This will cause the standard-type thermal overload relay to operate during starting so isolating the motor. If necessary FUJI will supply thermal relays with saturable reactors. (Time-delay type).

**Quick operating type overload relays**

The windings of submersible pump and compressor motors normally have a smaller overload capacity than those of standard motors, since they are generally cooled by the water and other medium being pumped. Q type overload relays will operate more quickly than the standard type in the face of a locked rotor current.

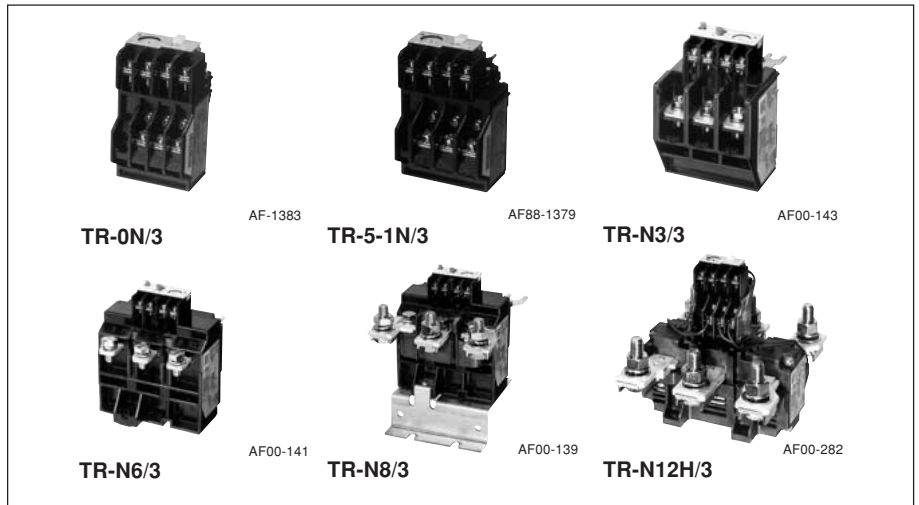

■ **Features**

- Isolated NO and NC contacts can be used with different potentials.
- Gold-flashed silver contact assures high contact reliability (TR-0N/3 to N14/3).
- Stable operating characteristics protect motors from burnout due to overload or locked rotor currents.
- Easy setting of current value with a calibrated dial.
- Both manual and auto reset available. A manual trip button is provided to facilitate sequence testing.
- Mechanical trip indication
- Trip-free mechanism is provided.
- Reset release button and trip indicator are optional accessories.

■ **Warning**

All FUJI thermal overload relays have been tested and calibrated at the factory. They should not be tampered with or stripped down at the job site since this would affect their accuracy. A special feature of the FUJI starter series is the ease by which the relay current ratings can be varied to match the requirements of the load. The changeover is effected by simply turning a dial to the new value required. The range of adjustment is approximately 100%–125%–150% and details are given overleaf.

■ **Ordering information**

- Specify the following:
1. Ordering code
  2. Setting range code
- [See page 01/98.](#)

■ **Type number nomenclature**

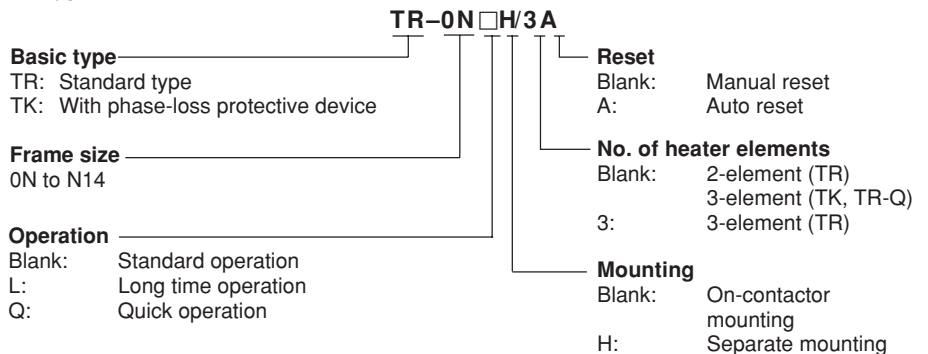

# Thermal Overload Relays

## TR series

### ■ Ordering code system

T R 2 0 B N W — T A  
 ① ② ③④ ⑤ ⑥ ⑦ — ⑧ ⑨

#### ① Product category

Description	Code
Thermal overload relay	T

#### ② Series category

Description	Code
TR-N□ series	R

#### ③④ Frame size

Frame size	Code	
	③	④
0N	1	3
5-1N	2	0
N2	3	5
N3	6	5
N5	9	3
N6	1	C
N7	1	F
N8	1	J
N10	2	C
N12	4	A
N14	6	A

#### ⑤ Index

Type	Code
TR-0N, 5-1N	Blank
TR-N2 to N14	B

#### ⑥ Version

Description	No. of element	Code
Standard	2	N
	3	D
Long time operation	2	L
	3	F
Quick operation	3	S
With phase-loss	3	E

#### ⑦ Mounting

Description	Code
On-contactor mounting	W
Separate mounting	H

#### ⑨ Reset

Description	Code
Manual reset	Blank
Auto reaset	A

#### ⑧ Thermal overload relay ampere setting range

Ampere setting range (A)	Code
0.1 — 0.15	A
0.13 — 0.2	B
0.15 — 0.24	C
0.2 — 0.3	D
0.24 — 0.36	E
0.3 — 0.45	F
0.36 — 0.54	G
0.48 — 0.72	H
0.64 — 0.96	J
0.8 — 1.2	K
0.95 — 1.45	L
1.4 — 2.2	M
1.7 — 2.6	N
2.2 — 3.4	P
2.8 — 4.2	R
4 — 6	S
5 — 8	T
6 — 9	U
7 — 11	V
9 — 13	W
12 — 18	X
16 — 22	Q
18 — 26	B
24 — 36	E
28 — 40	F
32 — 42	I
34 — 50	G
45 — 65	J
48 — 68	O
53 — 80	L
65 — 95	M
85 — 105	I
85 — 125	N
110 — 160	P
125 — 185	R
160 — 240	S
200 — 300	T
240 — 360	U
300 — 450	V
400 — 600	W

### Ordering example

① Thermal overload relay ..... T  
 ② TR-□N series ..... R  
 ③④ Frame size: 5-1N ..... 20  
 ⑤ Index ..... Blank  
 ⑥ Standard type, 3-element ..... D  
 ⑦ On-contactor mounting ..... W  
 —  
 ⑧ Ampere setting range 4-6A ..... S  
 ⑨ Auto reset ..... A

TR20DW-SA

① Thermal overload relay ..... T  
 ② TR-N□ series ..... R  
 ③④ Frame size: N3 ..... 65  
 ⑤ Index ..... B  
 ⑥ With phase-loss protection ..... E  
 ⑦ On-contactor mounting ..... W  
 —  
 ⑧ Ampere setting range 24-36A ..... E  
 ⑨ Manual reset ..... Blank

TR65BEW-E

■ Features

● Manual trip

These relays can be manually tripped for sequence inspection by pressing manual trip bar (TR-0N/3, TR-5-1N/3). A sequence inspection will be performed when the test button is pulled out. When the test button is pressed in, only the NC contact will turn OFF. The original status will be restored when the test button is then released.(TR-N2/3 to N8/3)

● Trip-free mechanism

Even if the reset button is carelessly pressed, this relay trips without trouble (Trip-free mechanism).

● Easy visual checking of operating status

Trip indicator and manual trip bar permit visual check of tripping status.



● Dial ampere setting

The setting dial uses a RC (Rated Current) marking which is set to the motor full load current.

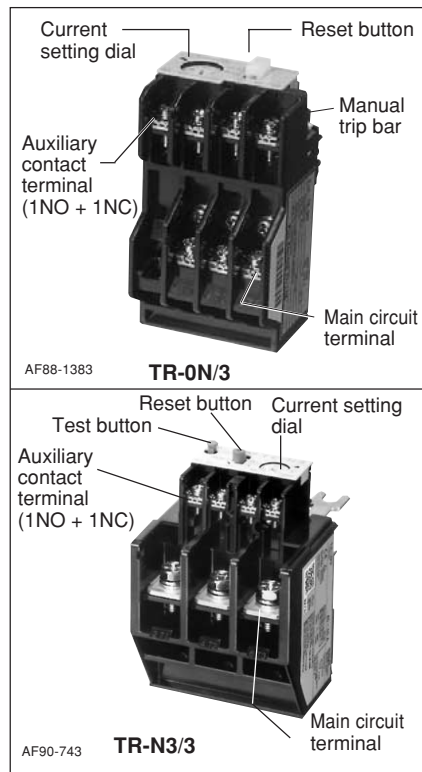

■ Versatile optional accessories  
Trip indicator



Reset release



Base unit for separate mounting



■ Optional accessories

Description		Type	Ordering code	Used with thermal overload relay
Reset release	Lead length 300 mm	SZ-R1 SZ-R2 SZ-R3	TZ1R1	TR-0N/3, TR-5-1N/3, TK-0N, TK-5-1N
	500 mm		TZ1R2	
	700 mm		TZ1R3	
You can reset these relays remotely on the front panels of switchboards.	Lead length 300 mm	SZ-R4 SZ-R5 SZ-R6	TZ2R4	TR-N10 to N14, TK-N10 to N14
	500 mm		TZ2R5	
	700 mm		TZ2R6	
Trip indicator	100–110V AC 50/60Hz	SZ-L100 SZ-L200	TZ1L100	TR-0N/3, TR-5-1N/3, TK-0N, TK-5-1N
	200–220V AC 50/60Hz		TZ1L200	
Easier checking of trip status	100–110V AC 50/60Hz	SZ-L100N2 SZ-L200N2	TZ2L100N2	TR-N2/3 to N8/3, TK-N2 to N8
	200–220V AC 50/60Hz		TZ2L200N2	
Dial cover For protection against the current setting being changed in error		SZ-DA	SZ1DA	TR-0N/3, TR-5-1N/3, TK-0N, TK-5-1N TR-N2/3 to N14/3, TK-N2 to N14
Base unit for separate mounting The unit can be screw-mounted and rail-mounted.		SZ-HB	TZ1HB	TR-0N/3, TK-0N
		SZ-HC	TZ1HC	TR-5-1N/3, TK-5-1N
		SZ-HD	TZ2HD	TR-N2/3, TK-N2
		SZ-HE	TZ2HE	TR-N3/3, TK-N3
Terminal cover		SZ-T10	SZ1T10	Base unit for separate mounting SZ-HB
		SZ-T11	SZ1T11	Base unit for separate mounting SZ-HC
		SZ-T14	SZ2T14	For separate mounting TR-N2H/3, TK-N2H
		SZ-T15	SZ2T15	For separate mounting TR-N3H/3, TK-N3H
		SZ-RN6T	SZ2RN6T	For separate mounting TR-N6H/3, TK-N6H
		SZ-T12	TZ1T12	TR-0N/3, TK-0N
		SZ-T13	TZ1T13	TR-5-1N/3, TK-5-1N
		SZ-T16	SZ2T16	TR-N2/3, TK-N2
	SZ-T17	SZ2T17	TR-N3/3, TK-N2	

# Thermal Overload Relays

## TR series

### Standard type

#### ■ Selection guide/Standard type

On-contactor mounting	3-element	<b>TR-0N/3</b> (TR13DW) <b>TR-0N</b> (TR13NW)		<b>TR-5-1N/3</b> (TR20DW) <b>TR-5-1N</b> (TR20NW)		<b>TR-N2/3</b> (TR35BDW) <b>TR-N2</b> (TR35BNW)		<b>TR-N3/3</b> (TR65BDW) <b>TR-N3</b> (TR65BNW)	
	2-element								
Separate mounting	3-element	<b>TR-0NH/3</b> (TR13DH) <b>TR-0NH</b> (TR13NH)		<b>TR-5-1NH/3</b> (TR20DH) <b>TR-5-1NH</b> (TR20NH)		<b>TR-N2H/3</b> (TR35BDH) <b>TR-N2H</b> (TR35BNH)		<b>TR-N3H/3</b> (TR65BDH) <b>TR-N3H</b> (TR65BNH)	
	2-element								
Contactor to be combined		SC-03	SC-0 SC-05	SC-4-0	SC-4-1 SC-5-1	SC-N1	SC-N2	SC-N2S	SC-N3
Ampere setting range (A)	<b>Code</b>	<b>A</b>	0.1 – 0.15	0.1 – 0.15	0.1 – 0.15	0.1 – 0.15			
	<b>B</b>	0.13 – 0.2	0.13 – 0.2	0.13 – 0.2	0.13 – 0.2				
	<b>C</b>	0.15 – 0.24	0.15 – 0.24	0.15 – 0.24	0.15 – 0.24				
	<b>D</b>	0.2 – 0.3	0.2 – 0.3	0.2 – 0.3	0.2 – 0.3				
	<b>E</b>	0.24 – 0.36	0.24 – 0.36	0.24 – 0.36	0.24 – 0.36				
	<b>F</b>	0.3 – 0.45	0.3 – 0.45	0.3 – 0.45	0.3 – 0.45				
	<b>G</b>	0.36 – 0.54	0.36 – 0.54	0.36 – 0.54	0.36 – 0.54				
	<b>H</b>	0.48 – 0.72	0.48 – 0.72	0.48 – 0.72	0.48 – 0.72				
	<b>J</b>	0.64 – 0.96	0.64 – 0.96	0.64 – 0.96	0.64 – 0.96				
	<b>K</b>	0.8 – 1.2	0.8 – 1.2	0.8 – 1.2	0.8 – 1.2				
	<b>L</b>	0.95 – 1.45	0.95 – 1.45	0.95 – 1.45	0.95 – 1.45				
	<b>M</b>	1.4 – 2.2	1.4 – 2.2	1.4 – 2.2	1.4 – 2.2				
	<b>N</b>	1.7 – 2.6	1.7 – 2.6	1.7 – 2.6	1.7 – 2.6				
	<b>P</b>	2.2 – 3.4	2.2 – 3.4	2.2 – 3.4	2.2 – 3.4				
	<b>R</b>	2.8 – 4.2	2.8 – 4.2	2.8 – 4.2	2.8 – 4.2				
	<b>S</b>	4 – 6	4 – 6	4 – 6	4 – 6	4 – 6	4 – 6		
	<b>T</b>	5 – 8	5 – 8	5 – 8	5 – 8	5 – 8	5 – 8		
	<b>U</b>	6 – 9	6 – 9	6 – 9	6 – 9	6 – 9	6 – 9		
	<b>V</b>	7 – 11	7 – 11	7 – 11	7 – 11	7 – 11	7 – 11	7 – 11	7 – 11
	<b>W</b>		9 – 13	9 – 13	9 – 13	9 – 13	9 – 13	9 – 13	9 – 13
<b>X</b>			12 – 18	12 – 18	12 – 18	12 – 18	12 – 18	12 – 18	
<b>Q</b>				16 – 22					
<b>B</b>					18 – 26	18 – 26	18 – 26	18 – 26	
<b>E</b>					24 – 36	24 – 36	24 – 36	24 – 36	
<b>F</b>							28 – 40	28 – 40	
<b>I</b>						32 – 42			
<b>G</b>							34 – 50	34 – 50	
<b>J</b>							45 – 65	45 – 65	
<b>O</b>								48 – 68	
<b>L</b>								53 – 80*	
<b>M</b>								65 – 95*	
<b>I</b>								85 – 105*	

On-contactor mounting	3-element	<b>TR-N5/3</b> (TR80BDW) <b>TR-N5</b> (TR80BNW)		<b>TR-N6/3</b> (TR1CBDW) <b>TR-N6</b> (TR1CBNW)	<b>TR-N7/3</b> (TR1FBDW) <b>TR-N7</b> (TR1FBNW)	<b>TR-N8/3</b> (TR1JBDW) <b>TR-N8</b> (TR1JBNW)	<b>TR-N10/3</b> (TR2CBDW) <b>TR-N10</b> (TR2CBNW)	<b>TR-N12/3</b> (TR4ABDW) <b>TR-N12</b> (TR4ABNW)	<b>TR-N14/3</b> (TR8ABDW) <b>TR-N14</b> (TR8ABNW)	
	2-element									
Separate mounting	3-element	-		<b>TR-N6H/3</b> (TR1CBDH) <b>TR-N6H</b> (TR1CBNH)	-	-	<b>TR-N10H/3</b> (TR2CBDH) <b>TR-N10H</b> (TR2CBNH)	<b>TR-N12H/3</b> (TR4ABDH) <b>TR-N12H</b> (TR4ABNH)	<b>TR-N14H/3</b> (TR8ABDH) <b>TR-N14H</b> (TR8ABNH)	
	2-element	-								
Contactor to be combined		SC-N4	SC-N5	SC-N6	SC-N7	SC-N8	SC-N10	SC-N11	SC-N12	SC-N14
Ampere setting range (A)	<b>Code</b>	<b>B</b>	18 – 26	18 – 26						
	<b>E</b>	24 – 36	24 – 36							
	<b>F</b>	28 – 40	28 – 40							
	<b>G</b>	34 – 50	34 – 50							
	<b>J</b>	45 – 65	45 – 65	45 – 65	45 – 65					
	<b>L</b>	53 – 80	53 – 80	53 – 80	53 – 80					
	<b>M</b>		65 – 95	65 – 95	65 – 95	65 – 95				
	<b>I</b>		85 – 105							
	<b>N</b>			85 – 125	85 – 125	85 – 125	85 – 125			
	<b>P</b>			110 – 160*	110 – 160	110 – 160	110 – 160	110 – 160	110 – 160	
	<b>R</b>					125 – 185	125 – 185	125 – 185	125 – 185	
	<b>S</b>						160 – 240	160 – 240	160 – 240	
	<b>T</b>							200 – 300	200 – 300	
	<b>U</b>								240 – 360	240 – 360
<b>V</b>								300 – 450	300 – 450	
<b>W</b>									400 – 600	

- Notes: • TR-N10/3 to N14/3 types are provided with CTs.  
 • Max. setting ranges of these starters are as shown in the table on the right.  
 • When ordering the thermal overload relays for starter use, select the applicable setting range.  
 ( ) : Basic ordering code (When ordering phase-loss protective type, enter the version code E instead of D)  
 \* : Separate mounting only

Motor starter	Maximum applicable heater range (A)	
	200–240V	380–440V
SW-03/3H	7–11	6–9
SW-4-0/3H	12–18	12–18
SW-N1/3H	24–36	24–36
SW-N2S/3H	34–50	34–50
SW-N4/3H	53–80	53–80
SW-N6/3H	85–125	85–125



■ Selection guide/Long time operating type

On-contactor mounting	3-element	-		-		TR-N2L/3 (TR35BFW)		TR-N3L/3 (TR65BFW)	
	2-element	-		-		TR-N2L (TR35BLW)		TR-N3L (TR65BLW)	
Separate mounting	3-element	TR-0NLH/3 (TR13FH)		TR-5-1NLH/3 (TR20FH)		TR-N2LH/3 (TR35BFH)		TR-N3LH/3 (TR65BFH)	
	2-element	TR-0NLH (TR13LH)		TR-5-1NLH (TR20LH)		TR-N2LH (TR35BLH)		TR-N3LH (TR65BLH)	
Contactor to be combined		SC-03	SC-0 SC-05	SC-4-0	SC-4-1 SC-5-1	SC-N1	SC-N2	SC-N2S	SC-N3
Ampere setting range (A)	<b>Code</b>	<b>L</b>	0.95 – 1.45	0.95 – 1.45	0.95 – 1.45	0.95 – 1.45			
	<b>M</b>	1.4 – 2.2	1.4 – 2.2	1.4 – 2.2	1.4 – 2.2	1.4 – 2.2			
	<b>N</b>	1.7 – 2.6	1.7 – 2.6	1.7 – 2.6	1.7 – 2.6	1.7 – 2.6			
	<b>P</b>	2.2 – 3.4	2.2 – 3.4	2.2 – 3.4	2.2 – 3.4	2.2 – 3.4			
	<b>R</b>	2.8 – 4.2	2.8 – 4.2	2.8 – 4.2	2.8 – 4.2	2.8 – 4.2			
	<b>S</b>	4 – 6	4 – 6	4 – 6	4 – 6	4 – 6	4 – 6	4 – 6	
	<b>T</b>	5 – 8	5 – 8	5 – 8	5 – 8	5 – 8	5 – 8	5 – 8	
	<b>U</b>	6 – 9	6 – 9	6 – 9	6 – 9	6 – 9	6 – 9	6 – 9	
	<b>V</b>	7 – 11	7 – 11	7 – 11	7 – 11	7 – 11	7 – 11	7 – 11	7 – 11
	<b>W</b>		9 – 13	9 – 13	9 – 13	9 – 13	9 – 13	9 – 13	9 – 13
	<b>X</b>			12 – 18	12 – 18	12 – 18	12 – 18	12 – 18	12 – 18
	<b>B</b>					18 – 26	18 – 26	18 – 26	18 – 26
	<b>E</b>						24 – 36	24 – 36	24 – 36
	<b>F</b>							28 – 40	28 – 40
<b>G</b>							34 – 50	34 – 50	
<b>J</b>								45 – 65	
<b>L</b>								53 – 80*	
<b>M</b>								65 – 95*	

On-contactor mounting	3-element	TR-N5L/3 (TR80BFW)		TR-N6L/3 (TR1CBFW)		TR-N7L/3 (TR1FBFW)		TR-N10L/3 (TR2CBFW)		TR-N12L/3 (TR4ABFW)		TR-N14L/3 (TR8ABFW)	
	2-element	TR-N5L (TR80BLW)		TR-N6L (TR1CBLW)		TR-N7L (TR1FBLW)		TR-N10L (TR2CBLW)		TR-N12L (TR4ABLW)		TR-N14L (TR8ABLW)	
Separate mounting	3-element	-		TR-N6LH/3 (TR1CBFH)		-		TR-N10LH/3 (TR2CBFH)		TR-N12LH/3 (TR4ABFH)		TR-N14LH/3 (TR8ABFH)	
	2-element	-		TR-N6LH (TR1CBLH)		-		TR-N10LH (TR2CBLH)		TR-N12LH (TR4ABLH)		TR-N14LH (TR8ABLH)	
Contactor to be combined		SC-N4	SC-N5	SC-N6	SC-N7	SC-N8	SC-N10	SC-N11	SC-N12	SC-N14			
Ampere setting range (A)	<b>Code</b>	<b>B</b>	18 – 26	18 – 26									
	<b>E</b>	24 – 36	24 – 36										
	<b>F</b>	28 – 40	28 – 40										
	<b>G</b>	34 – 50	34 – 50										
	<b>J</b>	45 – 65	45 – 65	45 – 65	45 – 65								
	<b>L</b>	53 – 80	53 – 80	53 – 80	53 – 80								
	<b>M</b>		65 – 95	65 – 95	65 – 95								
	<b>N</b>				85 – 125	85 – 125	85 – 125	85 – 125					
	<b>P</b>				110 – 160*	110 – 160	110 – 160	110 – 160	110 – 160	110 – 160	110 – 160	110 – 160	
	<b>R</b>						125 – 185	125 – 185	125 – 185	125 – 185	125 – 185	125 – 185	
	<b>S</b>							160 – 240	160 – 240	160 – 240	160 – 240	160 – 240	
	<b>T</b>								200 – 300	200 – 300	200 – 300	200 – 300	
	<b>U</b>									240 – 360	240 – 360	240 – 360	240 – 360
	<b>V</b>									300 – 450	300 – 450	300 – 450	300 – 450
<b>W</b>											400 – 600	400 – 600	

Notes: Maximum setting ranges of these starters are as shown in the table below. ( ): Basic ordering code  
Select the applicable setting range when ordering the thermal overload relays for starter use. \*: Separate mounting only

Motor starter	Maximum applicable heater range (A)	
	200–240V	380–440V
SW-03/2L, 3L	7–11	6–9
SW-N2S/2L, 3L	34–50	34–50
SW-N4/2L, 3L	53–80	53–80
SW-N6/2L, 3L	85–125	85–125

# Thermal Overload Relays

## TR series

### Quick operating type

#### ■ Selection guide/Quick operating type

On-contactor mounting	3-element	<b>TR-0NQ</b> (TR13SW)		<b>TR-5-1NQ</b> (TR20SW)		<b>TR-N2Q</b> (TR35BSW)	
Separate mounting	3-element	-		-		-	
Contactor to be combined		SC-03	SC-0 SC-05	SC-4-0	SC-4-1 SC-5-1	SC-N1	SC-N2
Rated operational current (A)	200-240V 380-440V	11 9	13 12	18 16	22 22	27 30	39 37
Ampere setting range (A)	<b>Code</b>	<b>M</b>	1.4 - 2.2	1.4 - 2.2	1.4 - 2.2	1.4 - 2.2	
		<b>N</b>	1.7 - 2.6	1.7 - 2.6	1.7 - 2.6	1.7 - 2.6	
		<b>P</b>	2.2 - 3.4	2.2 - 3.4	2.2 - 3.4	2.2 - 3.4	
		<b>R</b>	2.8 - 4.2	2.8 - 4.2	2.8 - 4.2	2.8 - 4.2	
		<b>S</b>	4 - 6	4 - 6	4 - 6	4 - 6	
		<b>T</b>	5 - 8	5 - 8	5 - 8	5 - 8	
		<b>U</b>	6 - 9	6 - 9	6 - 9	6 - 9	
		<b>V</b>	7 - 11 *1	7 - 11 *1	7 - 11 *1	7 - 11 *1	
		<b>W</b>		9 - 13 *1	9 - 13 *1	9 - 13 *1	
		<b>X</b>			12 - 18 *1	12 - 18 *1	12 - 18
		<b>B</b>				18 - 26	18 - 26
		<b>E</b>					24 - 36

On-contactor mounting	3-element	<b>TR-N3Q</b> (TR65BSW)		<b>TR-N5Q</b> (TR80SW)	
Separate mounting	3-element	<b>TR-N3Q</b> (TR65BSW)		-	
Contactor to be combined		SC-N2S	SC-N3	SC-N4	SC-N5
Rated operational current (A)	200-240V 380-440V	52 48	65 65	80 80	105 105
Ampere setting range (A)	<b>Code</b>	<b>B</b>	18-26	18-26	18-26
		<b>E</b>	24-36	24-36	24-36
		<b>F</b>	28-40	28-40	28-40
		<b>G</b>	34-50	34-50	34-50
		<b>J</b>		45-65	45-65
		<b>L</b>		53-80 *2	53-80
		<b>M</b>		65-95 *2	65-95

Notes: \*1 Thermal overload relay with phase-loss protection is available with \*1 marked setting ranges of TR-0NQ, TR-5-1NQ and all setting ranges of TR-N2Q to N5Q.

Type numbers are TK-0NQ, TK-5-1NQ, TK-N2Q to N5Q. The setting ranges of these TK-□Q type relays are as same as those of the above setting ranges.

\*2 Separate mounting only.

( ) Basic ordering code

#### ■ Ratings of auxiliary contact

Type	Rated thermal current (A)	Rated voltage (V)	Rated AC operational current (A)	Rated DC operational current (A)
TR-0N, 5-1N TR-0N/3, 5-1N/3 TK-0N, 5-1N TR-0NQ, 5-1NQ	3	24 100-120 200-240 380-440 500-600	3 (0.3)* 2.5 (0.3)* 2 (0.3)* 1 (0.3)* 0.6 (0.3)*	1.1 (0.3)* 0.28 0.14 - -
TR-N2 to N8 TR-N2/3 to N8/3 TK-N2 to N8 TR-N2Q to N5Q	5	24 100-120 200-240 380-440 500-600	3 (0.5)* 2.5 (0.5)* 2 (0.5)* 1 (0.5)* 0.6 (0.5)*	1.1 (0.3)* 0.28 0.14 - -
TR-N10 to N14 TR-N10/3 to N14/3 TK-N10 to N14	5	24 100-120 200-240 380-440 500-600	3 (0.3)* 2.5 (0.3)* 2 (0.3)* 1 (0.3)* 0.6 (0.3)*	1.1 (0.3)* 0.28 0.14 - -

Notes: Conforming to Class AC-15, DC-13, IEC, JIS, and JEM.

( ) \* NO contact of auto reset type.

■ Dimensions, mm  
Standard and quick operating types  
TR-0N/3, TR-0NQ  
On-contactor mounting

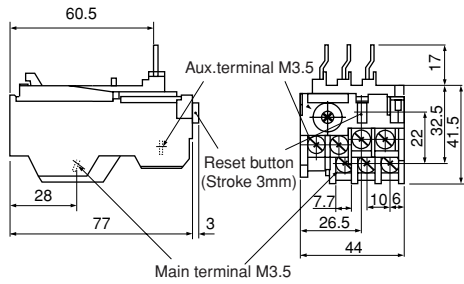

TR-0NH/3

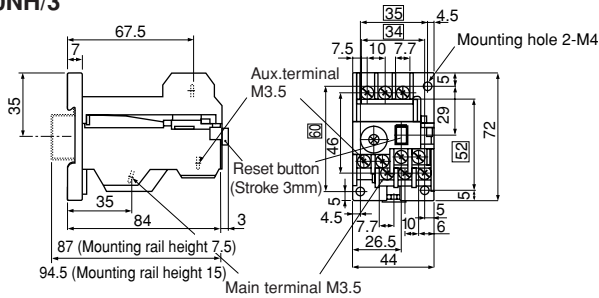

TR-5-1N/3, TR-5-1NQ  
On-contactor mounting

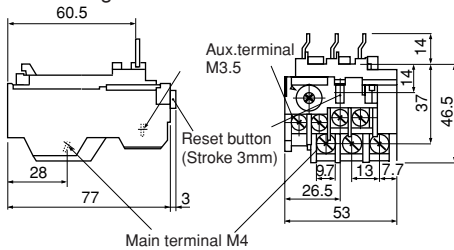

TR-5-1NH/3

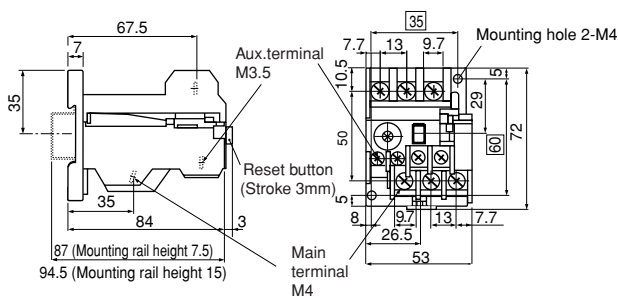

TR-N2/3, TR-N2Q  
On-contactor mounting

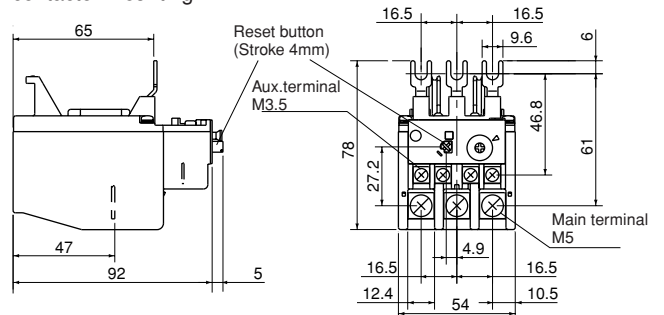

TR-N2H/3

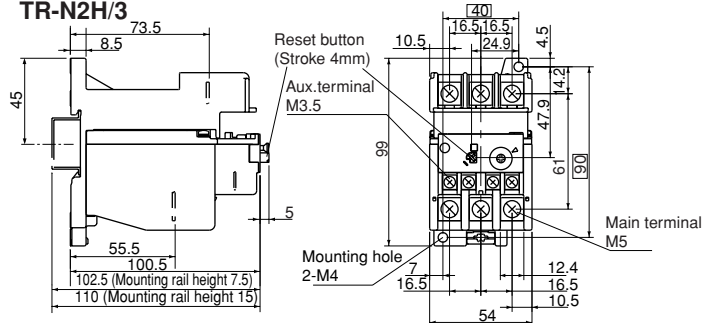

TR-N3/3, TR-N3Q  
On-contactor mounting

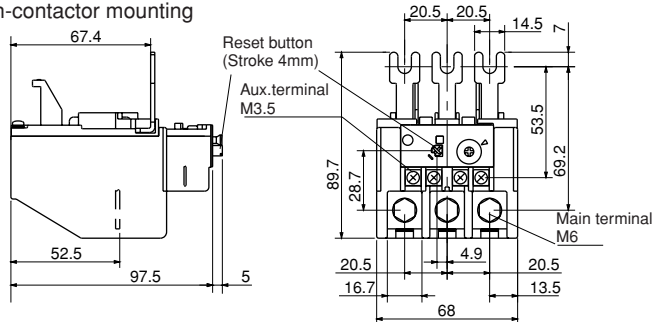

TR-N3H/3

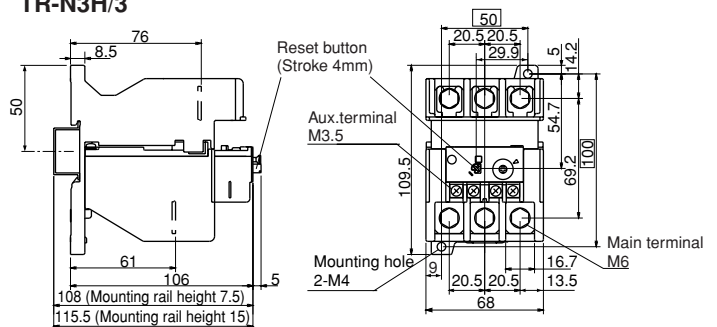

TR-N5/3, TR-N5Q  
On-contactor mounting

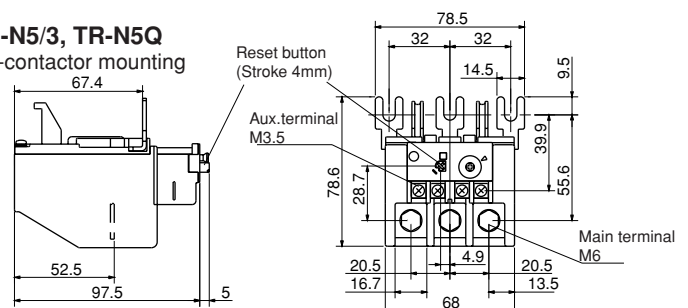

□ : Mounting pitch  
Mass: See page 01/105.

# Thermal Overload Relays

## TR series

### ■ Dimensions, mm Standard and quick operating types

#### TR-6N/3

On-contactor mounting

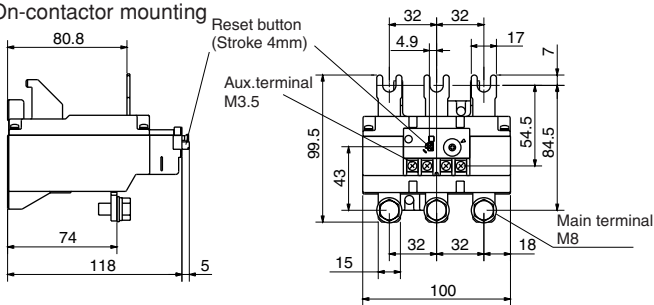

#### TR-N6H/3

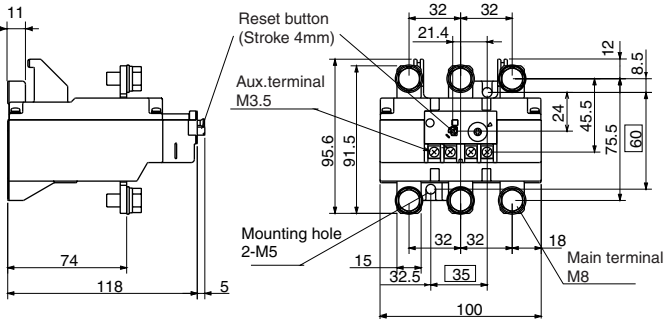

#### TR-N7/3

On-contactor mounting

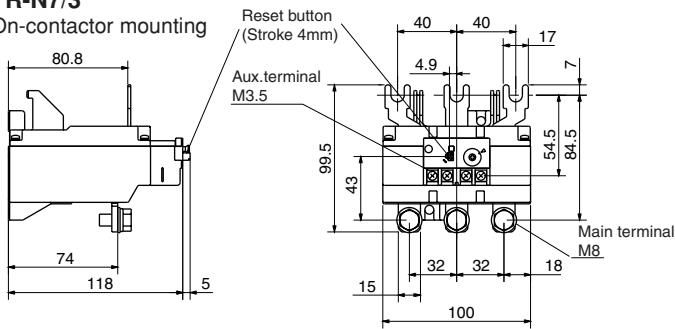

#### TR-N8/3

On-contactor mounting

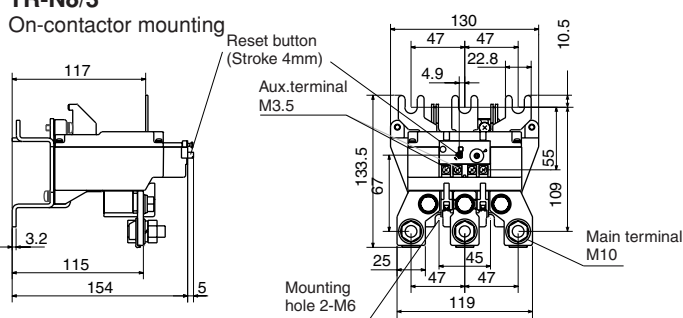

#### TR-N10/3

On-contactor mounting

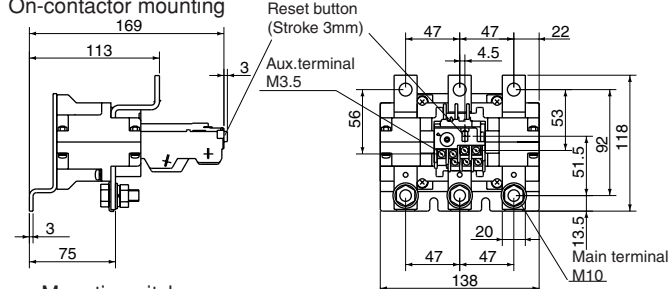

□ : Mounting pitch  
Mass: See page 01/105.

#### TR-N10H/3

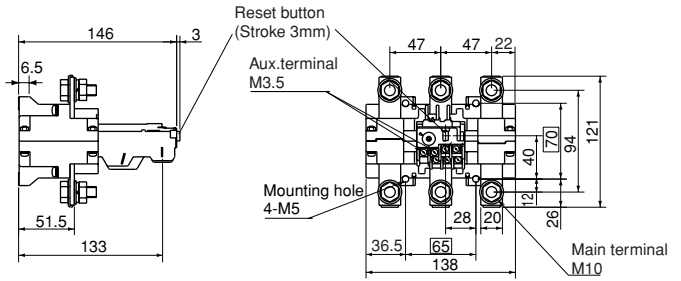

#### TR-N12/3

On-contactor mounting

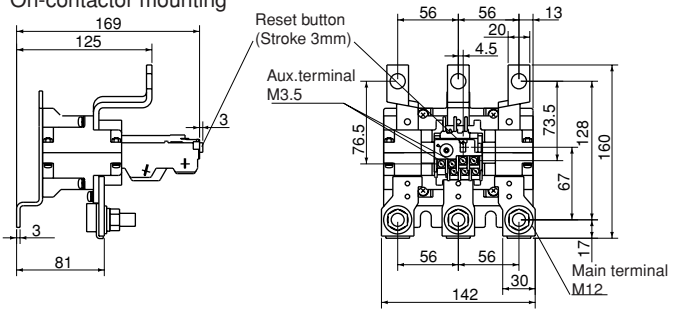

#### TR-N12H/3

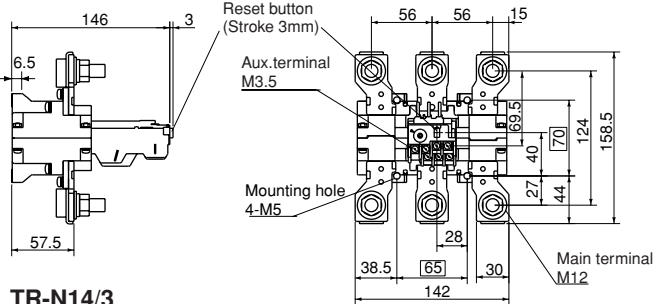

#### TR-N14/3

On-contactor mounting

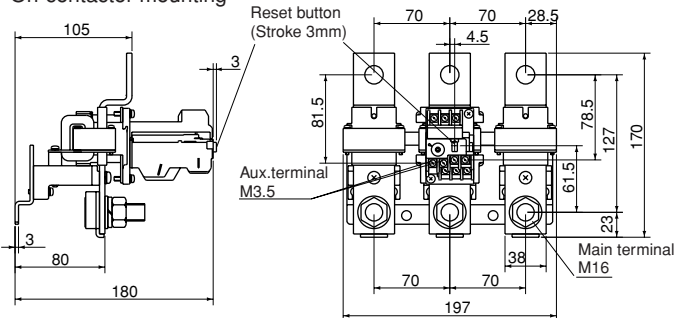

#### TR-N14H/3

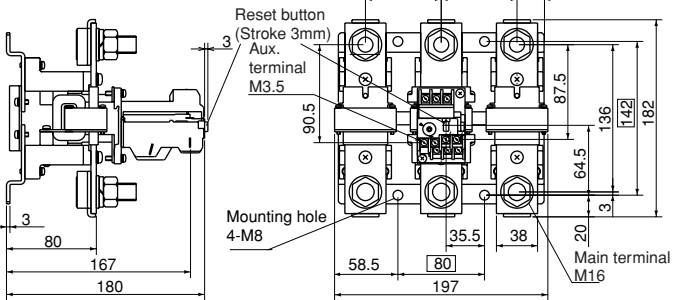

■ Dimensions, mm

Base unit for separate mounting

SZ-HB

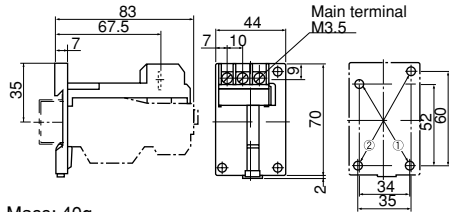

Mass: 40g

SZ-HC

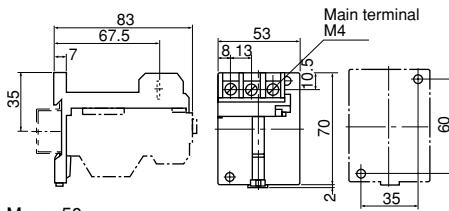

Mass: 50g

SZ-HD

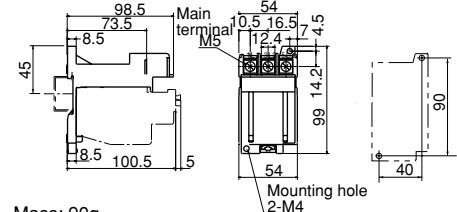

Mass: 90g

SZ-HE

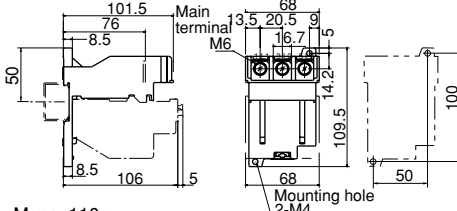

Mass: 110g

■ Mass/Standard and quick operating types

On-contactor mounting		Separate mounting		On-contactor mounting		Separate mounting	
Type	Mass	Type	Mass	Type	Mass	Type	Mass
TR-0N	0.09kg	TR-0NH	0.13kg	TR-N7	0.61kg		
TR-0N/3	0.10kg	TR-0NH/3	0.14kg	TR-N7/3	0.61kg		
TR-0NQ	0.10kg						
TR-5-1N	0.11kg	TR-5-1NH	0.16kg	TR-N8	1.2kg		
TR-5-1N/3	0.12kg	TR-5-1NH/3	0.17kg	TR-N8/3	1.2kg		
TR-5-1NQ	0.12kg						
TR-N2, N2/3	0.2kg	TR-N2H	0.29kg	TR-N10	1.85kg	TR-10NH	1.5kg
TR-N2Q	0.2kg	TR-N2H/3	0.29kg	TR-N10/3	1.85kg	TR-10NH/3	1.5kg
TR-N3, N3/3	0.27kg	TR-N3H, N3H/3	0.38kg	TR-N12, N12/3	2.3kg	TR-12NH, 12NH/3	2.25kg
TR-N3Q	0.27kg						
TR-N5, N5/3	0.27kg			TR-N14, N14/3	3.5kg	TR-14NH, 14NH/3	4kg
TR-N5Q	0.27kg						
TR-N6, N6/3	0.61kg	TR-N6H, N6H/3	0.67kg				

■ Dimensions, mm

Long time operating type

TR-0NLH, 0NLH/3

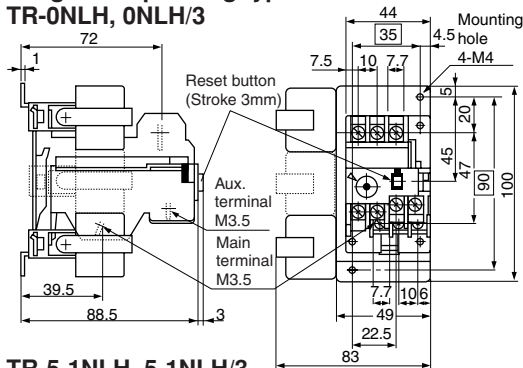

TR-5-1NLH, 5-1NLH/3

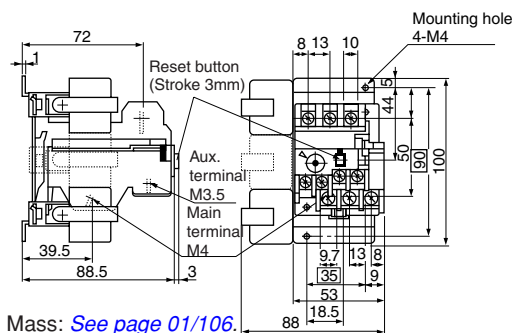

Mass: See page 01/106.

TR-N2L, N2L/3

On-contactor mounting

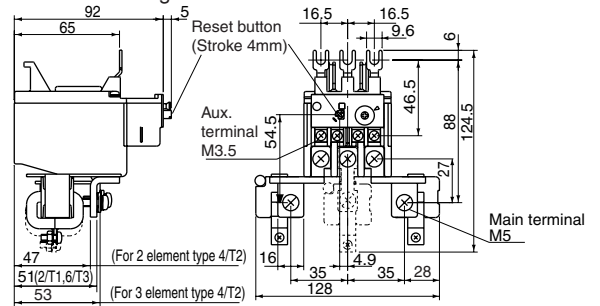

TR-N2LH, N2LH/3

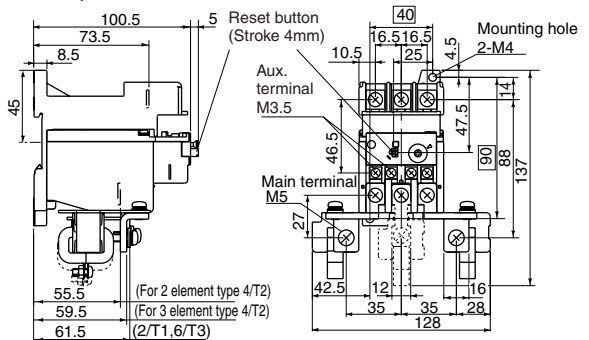

# Thermal Overload Relays

## TR series

### ■ Dimensions, mm

#### Long time operating type

#### TR-N3L, N3L/3

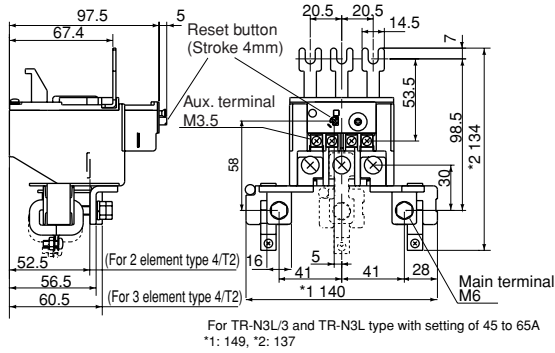

#### TR-N6L, N6L/3

#### On-contactor mounting

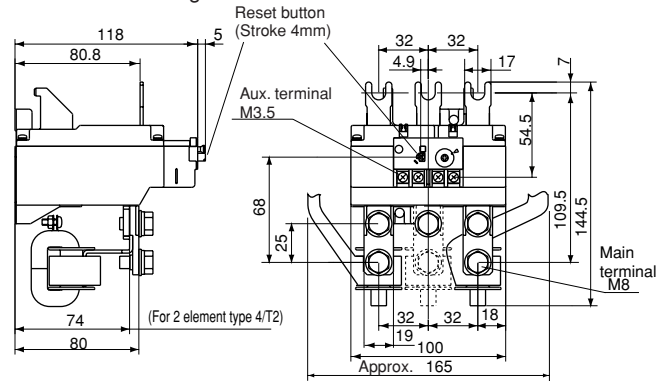

#### TR-N3LH, N3LH/3

#### On-contactor mounting

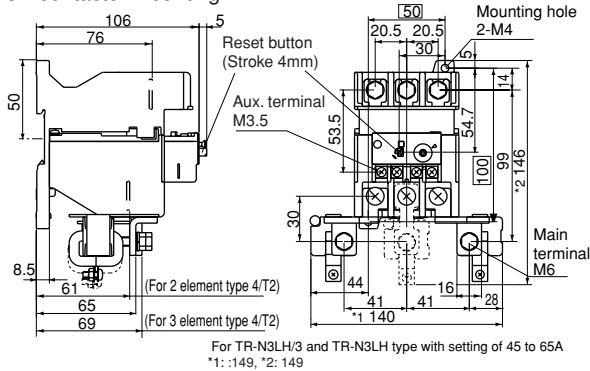

#### TR-N6LH, N6LH/3

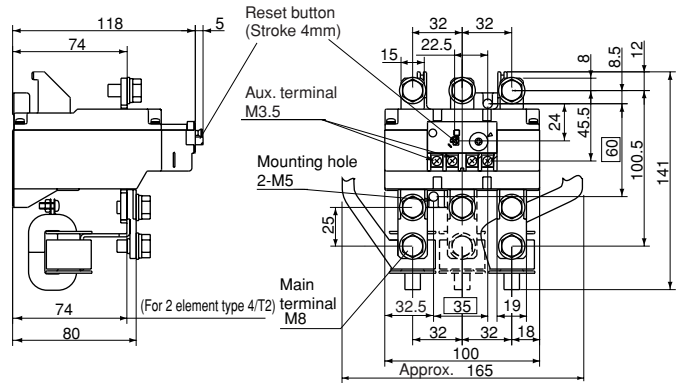

#### TR-N5L, N5LH/3

#### On-contactor mounting

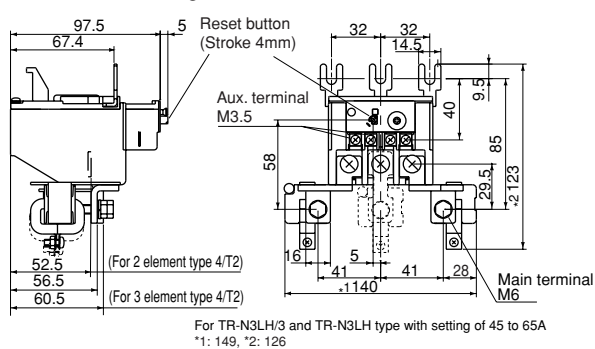

#### TR-N7L, N7L/3

#### On-contactor mounting

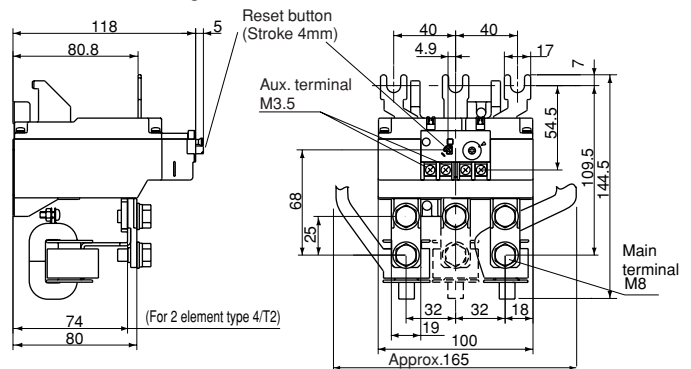

Note: TR-N10L, N10LH, N12NL, N12LH, N14L and N14LH types have the same dimensions as standard types. [See pages 01/105.](#)

### ■ Mass/Long time operating type

On-contactor mounting Type	Mass	Separate mounting Type	Mass	On-contactor mounting Type	Mass	Separate mounting Type	Mass
-		TR-0NLH	0.4kg	TR-N6L	1.54kg	TR-N6LH	1.6kg
-		TR-0NLH/3	0.5kg	TR-N6L/3	1.85kg	TR-N6LH/3	1.91kg
-		TR-5-1NLH	0.42kg	TR-N7L	1.54kg	-	
-		TR-5-1NLH/3	0.52kg	TR-N7L/3	1.85kg	-	
TR-N2L	0.56kg	TR-N2LH	0.65kg	TR-N10L	1.85kg	TR-N10LH	1.5kg
TR-N2L/3	0.68kg	TR-N2LH/3	0.77kg	TR-N10L/3	1.85kg	TR-N10LH/3	1.5kg
TR-N3L	0.63kg	TR-N3LH	0.74kg	TR-N12L	2.3kg	TR-N12LH	2.25kg
TR-N3L/3	0.77kg	TR-N3LH/3	0.88kg	TR-N12L/3	2.3kg	TR-N12LH/3	2.25kg
TR-N5L	0.63kg	-		TR-N14L	3.5kg	TR-N14LH	4kg
TR-N5L/3	0.77kg	-		TR-N14L/3	3.5kg	TR-N14LH/3	4kg

■ Dimensions, mm  
Optional accessories  
Trip indicator

SZ-L100  
SZ-L200

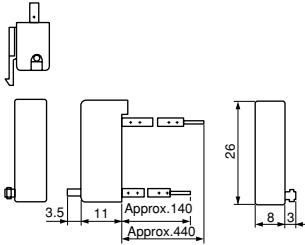

SZ-L100N2  
SZ-L200N2

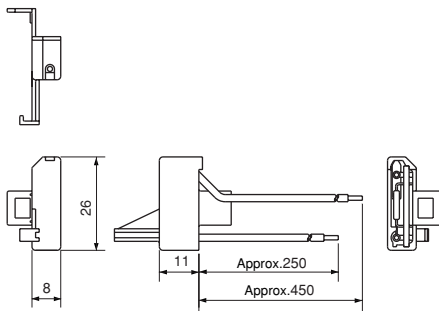

Reset release button

SZ-R1  
SZ-R2  
SZ-R3

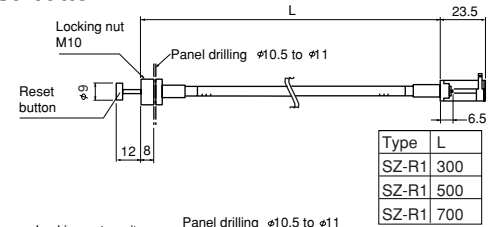

SZ-R4  
SZ-R5  
SZ-R6

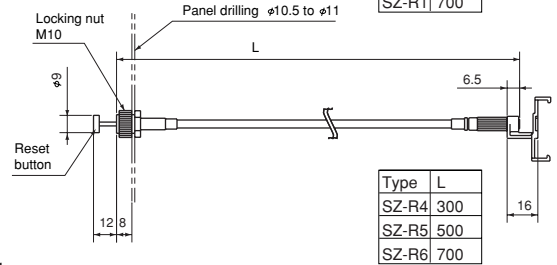

Dial cover  
SZ-DA

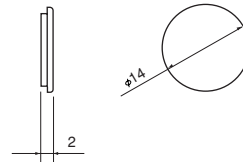

■ Characteristic curves These curves show cold starting characteristics.

● Standard type

TR-0N, 5-1N,  
TR-0N/3, 5-1N/3,  
TR-0NH, 5-1NH,  
TR-0NH/3, 5-1NH/3

TR-N2 to N8  
TR-N2/3 to N8/3  
TR-N2H, N3H, N6H  
TR-N2H/3, N3H/3, N6H/3

TR-N10 to N14,  
TR-N10/3 to N14/3,  
TR-N10H to N14H  
TR-N10H/3 to N14H/3

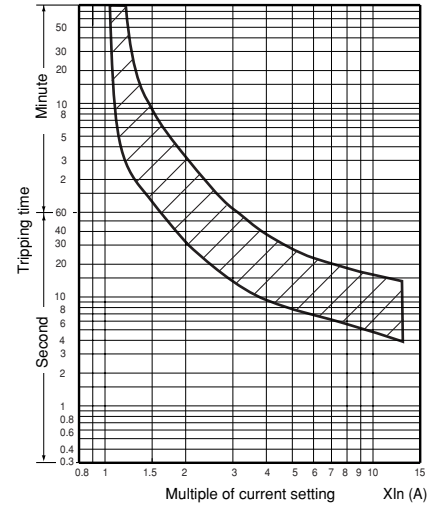
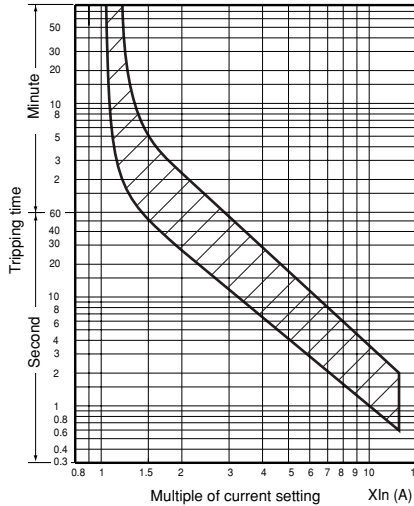
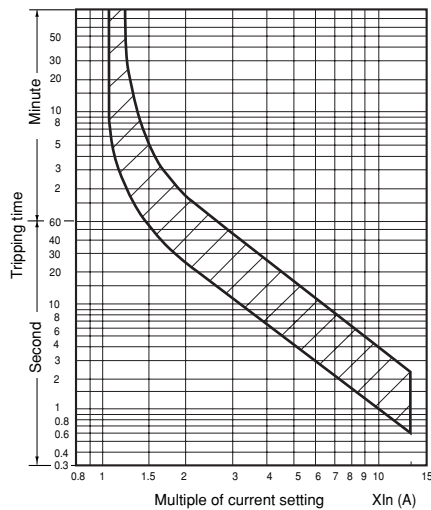

■ Wiring diagrams

● Standard type

TR-0N to N8  
TR-0N/3 to N8/3  
TR-0NH, 5-1NH, N2H, N3H, N6H  
TR-0NH/3, 5-1NH/3, N2H/3, N3H/3, N6H/3

2-element

3-element

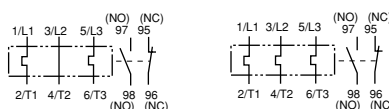

TR-N10 to N14  
TR-N10/3 to N14/3  
TR-N10H to N14H  
TR-N10H/3 to N14H/3

2-element  
(with CTs)

3-element  
(with CTs)

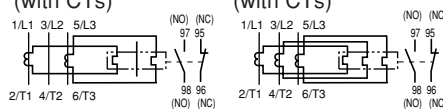

# Thermal Overload Relays TR series

■ **Characteristic curves** These curves show cold starting characteristics

● **Long time operating type** (When setting at the center dial current)

TR-0NL, 5-1NL

TR-0NL/3, 5-1NL/3

TR-0NLH, 5-1NLH

TR-0NLH/3, 5-1NLH/3

TR-N2L to N7L

TR-N2L/3 to N7L/3

TR-N2LH, N3LH, N6LH

TR-N2LH/3, N3LH/3, N6LH/3

TR-N10L to N14L

TR-N10L/3 to N14L/3

TR-N10LH to N14LH

TR-N10LH/3 to N14LH/3

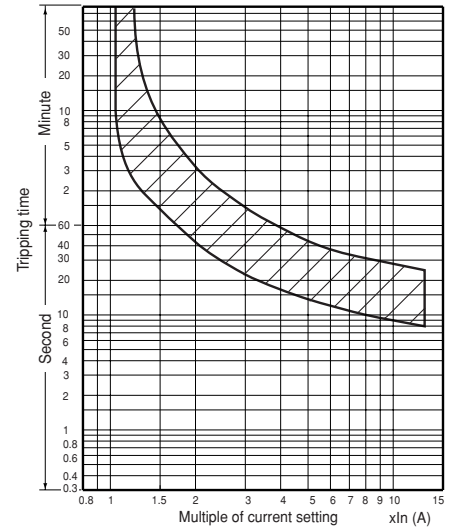
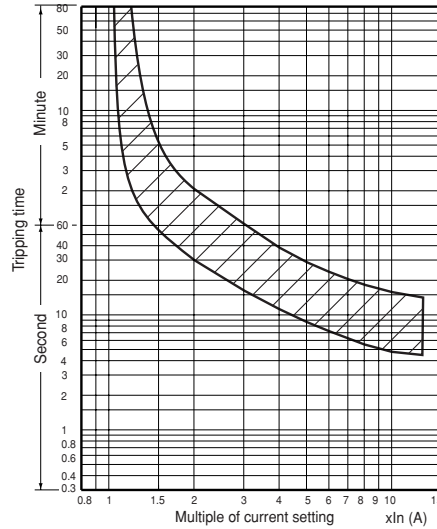
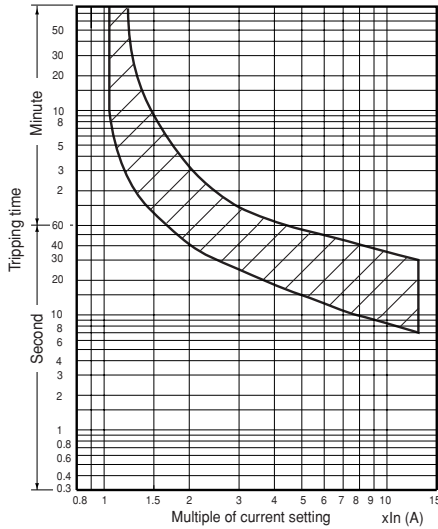

● **Quick operating type**

TR-0NQ, 5-1NQ

TR-N2Q, N3Q, N5Q

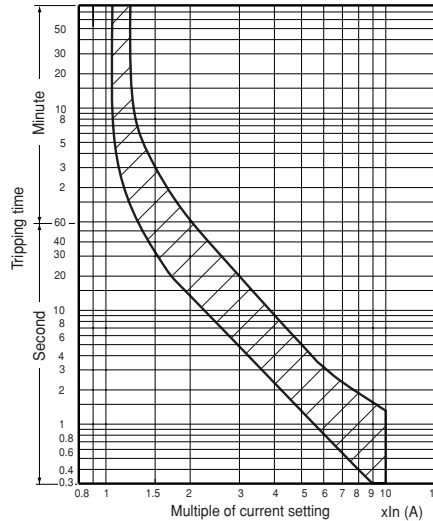
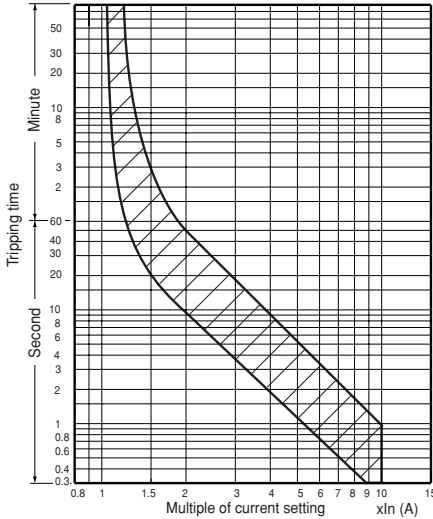

■ **Wiring diagrams**

● **Long time operating type**

TR-0NL to N7L

TR-0NL/3 to N7L/3

TR-0NLH, 5-1NLH, N2LH, N3LH, N6LH

TR-0NLH/3, 5-1NLH/3, N2LH/3, N3LH/3, N6LH/3

● **Quick operating type**

TR-0NQ, 5-1NQ

TR-N2Q, N3Q, N5Q

2-element

3-element

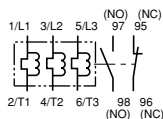
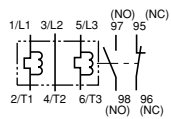

2-element  
(with CTs)

3-element  
(with CTs)

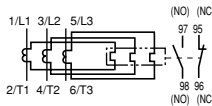
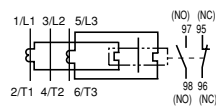

3-element

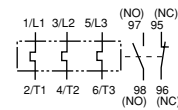



**Thermal overload relays with phase-loss protective device**

**■ Description**

FUJI TK series consists of a 3-heater element thermal overload relay and an phase-loss protective device. These two elements are assembled to make the relay unit. The overload relay characteristics are designed to meet the thermal characteristics of a squirrel-cage motors at the time of overload. A FUJI ADL mechanism is also provided to protect from phase-loss. This ADL mechanism is incorporated with the overload relay. The characteristics are coordinated with the temperature rise curve in stator winding at the time of motor phase-loss. They respond quickly to overloads. Other features include the following.

**■ Characteristics**

The operating characteristics of a thermal overload relays represents its tripping time and response current starting from cold or hot state.

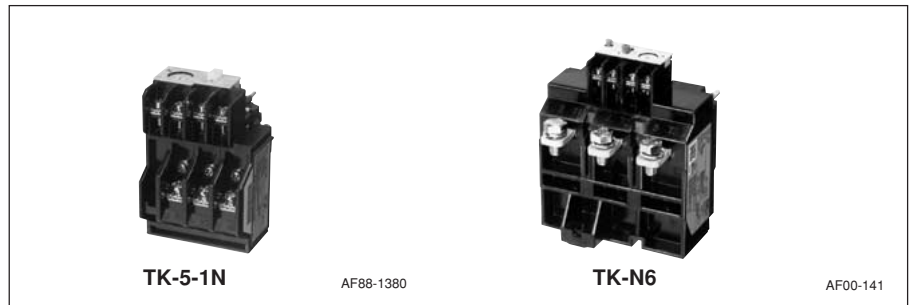

A trip-free mechanism, wide-range dial ampere adjustment, manual/auto reset chageover lever, operating indicator, and ambient temperature compensators. Types are available ranging from TK-0N to TK-N14.

**■ Ordering information**

Specify the following:  
1. Ordering code  
[See pages 01/98.](#)

**Cold starting characteristics**

In cold starting, tripping time is measured from the time when the temperature of the thermal overload relay is equal to the ambient temperature.

**Hot starting characteristics**

In hot starting, tripping time is measured from the time when the thermal overload relay reaches the steady state after non-tripping current flows two hours.

Standard	When all poles are equally energized			When all poles are not equally energized			Ambient temp.	
	Operating limit Non-tripping	Tripping	Overload (hot start)	Locked rotor (cold start)	Phase-loss protection	Operating limit Non-tripping		Tripping Hot start
IEC 60947-4-1	105% I <sub>e</sub>	120% I <sub>e</sub> (2h max.)	class 10A 150% I <sub>e</sub> 2min max.	class 10A 720% I <sub>e</sub> 2 to 10s max.	Not provided	3-phase: 105% I <sub>e</sub>	2-phase: 132% I <sub>e</sub>	20°C
			class 10 150% I <sub>e</sub> 4min max.	class 10 720% I <sub>e</sub> 4 to 10s max.			1-phase: 0 2h max.	
			class 20 150% I <sub>e</sub> 8min max.	class 20 720% I <sub>e</sub> 6 to 20s max.	Provided	2-phase: 100% I <sub>e</sub>	2-phase: 115% I <sub>e</sub>	
			class 30 150% I <sub>e</sub> 12min max.	class 30 720% I <sub>e</sub> 9 to 30s max. *		1-phase: 90% I <sub>e</sub>	1-phase: 0 2h max.	

**TK-0N, 5-1N  
TK-0NH, 5-1NH**

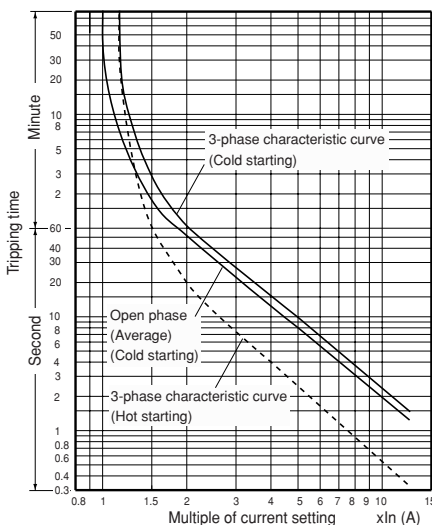

**■ Dimensions, mm**  
TK-0N to N14 types:  
Same as standard types  
[See pages 01/103, 01/104.](#)

**TK-N2, N3, N5, N6, N7, N8  
TK-N2H, N3H, N6H**

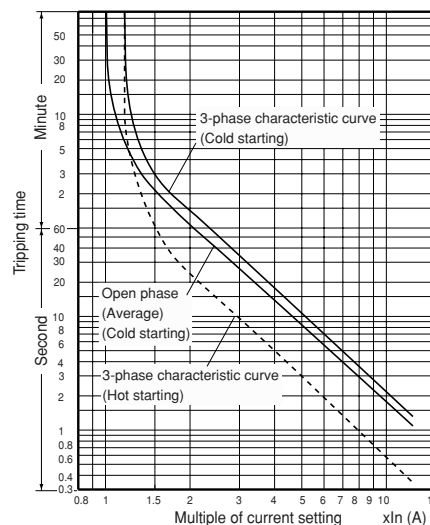

**■ Wiring diagrams**  
TK-0N to N14 types:  
Same as standard 3-heater element types  
[See pages 01/107.](#)

**TK-N10, N12, N14  
TK-N10H, N12H, N14H**

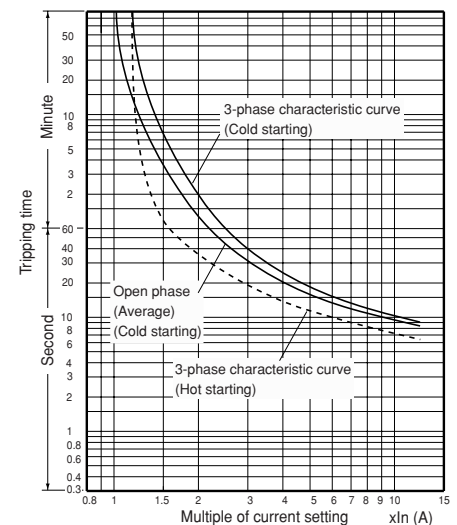

**■ Ratings of auxiliary contact**  
Same as standard types.  
[See Page 01/102.](#)

# Solid-state Contactors

## SS series

### General use

#### Solid-state contactors

##### General use

#### ■ Description

Solid-state contactors (SSC) are required in cases where contacts must have long life because contacts are frequently made and broken, and where contactor noise must be eliminated. Single and 3-pole solid-state contactors incorporate thyristors as making and breaking elements in the main circuit.

#### ■ Features

##### ● Operation indicator provided

An operation indicator LED (red) is provided as a standard feature for all models, so you can easily check whether a control voltage is applied to the SSC.

##### ● Long service life, optimum for highly frequent switching

The solid-state contactor utilizes high-performance semiconductor switch elements to include the functions and features of conventional magnetic contactors. The SSC, featuring long life, low-noise, and high-speed response, is suitable for highly frequent switching of various types of loads, such as motors and heaters.

#### ■ Specifications

##### Single-pole types

##### ● Main circuit 240V AC, SS101 to SS501

##### AC control voltage

Type	SS101-5Z-A3 SS101-5Z-A4	SS201-5Z-A3 SS201-5Z-A4	SS301-5Z-A3 SS301-5Z-A4	SS401-5Z-A3 SS401-5Z-A4	SS501-5Z-A3 SS501-5Z-A4
Ordering code	SS101-5ZA3 SS101-5ZA4	SS201-5ZA3 SS201-5ZA4	SS301-5ZA3 SS301-5ZA4	SS401-5ZA3 SS401-5ZA4	SS501-5ZA3 SS501-5ZA4
Main circuit	Rated voltage				
	100 — 240V AC 50/60Hz				
	Rated thermal current (A)*				
	10	20	30	40	50
Max. heater capacity (kW) Single phase 200V AC	2				
	4	6	8	10	
Number of elements					
Single-pole, 1-element					
Control circuit	Isolation method				
	Photocoupler				
	Control voltage Vn				
	A3: 100 — 120V AC, A4: 200 — 240V AC				
	Pick-up voltage				
Drop-out voltage					
85% Vn or less					
35% Vn and over					
Operating time (at 100% Vn)					
Release time (at 100% Vn)					
30ms or less					
30ms or less					
Auxiliary circuit	—				

Note: \* The values are the maximum ratings of type with cooling fin that apply at an ambient temperature not exceeding 40°C.

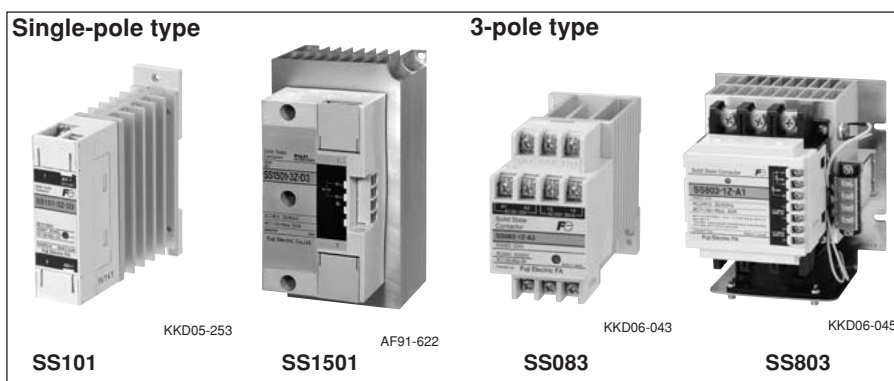

##### ● Built-in surge suppressor

Varistors and C-R circuits are included so that surge voltage due to SSC switching and lightning can be suppressed to protect the control and main circuits.

##### ● AC and DC operation

The AC and DC operated type SSCs are available, either of which can be selected as required.

##### ● SSC with zero-cross switching function

The SSC is also available with a zero-cross switching function to enable load current switching at the point where the line voltage is near zero to suppress excessive inrush current in the load circuit.

##### ● Built-in auxiliary contact

An auxiliary contact module using semiconductor switches or relay contacts is included. Therefore an auxiliary output signal can easily be obtained without using a separate auxiliary devices.

#### ■ Standards



■ **Specifications**

**Single-pole types**

● **Main circuit 240V AC, SS701 to SS2001**

**AC control voltage**

Type	SS701-1Z-A3 SS701-1Z-A4	SS1001-1Z-A3 SS1001-1Z-A4	SS1501-1Z-A3 SS1501-1Z-A4	SS2001-1Z-A3 SS2001-1Z-A4
Ordering code	SS701-1ZA3 SS701-1ZA4	SS1A1-1ZA3 SS1A1-1ZA4	SS1F1-1ZA3 SS1F1-1ZA4	SS2A1-1ZA3 SS2A1-1ZA4
Main circuit	Rated voltage			
	100 — 240V AC 50/60Hz			
	Rated thermal current (A)*	70	100	150
	Max. heater capacity (kW) Single phase 200V AC	14	20	30
Control circuit	Number of elements			
	Single-pole, 1-element			
	Isolation method			
	Photocoupler			
	Control voltage Vn			
A3: 100 — 120V AC, A4: 200 — 240V AC				
Pick-up voltage				
85% Vn or less				
Drop-out voltage				
35% Vn and over				
Operating time (at 100% Vn)				
30ms or less				
Release time (at 100% Vn)				
30ms or less				
Auxiliary circuit	Output			
	Thyristor 1NO			
Rated current and voltage				
A3: 50mA, 120V AC A4: 50mA, 240V AC				

Note: \* The values are the maximum ratings of type with cooling fin that apply at an ambient temperature not exceeding 40°C.

● **Main circuit 240V AC, SS101 to SS2001**

**DC control voltage**

Type	SS101-3Z-D3	SS201-3Z-D3	SS301-3Z-D3	SS401-3Z-D3	SS501-3Z-D3
Ordering code	SS101-3ZD3	SS201-3ZD3	SS301-3ZD3	SS401-3ZD3	SS501-3ZD3
Main circuit	Rated voltage				
	100 — 240V AC 50/60Hz				
	Rated thermal current (A)*	10	20	30	40
	Max. heater capacity (kW) Single phase 200V AC	2	4	6	8
Control circuit	Number of elements				
	Single-pole, 1-element				
	Isolation method				
	Photocoupler				
	Control voltage Vn				
5 — 24V DC					
Pick-up voltage					
3.5V or less					
Drop-out voltage					
1V and over					
Operating time (at 100% Vn)					
15ms or less					
Release time (at 100% Vn)					
15ms or less					
Auxiliary circuit	—				

Type	SS701-3Z-D3	SS1001-3Z-D3	SS1501-3Z-D3	SS2001-3Z-D3
Ordering code	SS701-3ZD3	SS1A1-3ZD3	SS1F1-3ZD3	SS2A1-3ZD3
Main circuit	Rated voltage			
	100 — 240V AC 50/60Hz			
	Rated thermal current (A)*	70	100	150
	Max. heater capacity (kW) Single phase 200V AC	14	20	30
Control circuit	Number of elements			
	Single-pole, 1-element			
	Isolation method			
	Photocoupler			
	Control voltage Vn			
5 — 24V DC				
Pick-up voltage				
3.5V or less				
Drop-out voltage				
1V and over				
Operating time (at 100% Vn)				
15ms or less				
Release time (at 100% Vn)				
15ms or less				
Auxiliary circuit	—			

Note: \* The values are the maximum ratings of type with cooling fin that apply at an ambient temperature not exceeding 40°C.

# Solid-state Contactors

## SS series

### General use

#### ■ Specifications

##### Single-pole types

##### ● Main circuit 480V AC, SS701H to SS2001H

##### AC control voltage

Type	SS701H-1Z-A3 SS701H-1Z-A4	SS1001H-1Z-A3 SS1001H-1Z-A4	SS1501H-1Z-A3 SS1501H-1Z-A4	SS2001H-1Z-A3 SS2001H-1Z-A4
Ordering code	SS701H-1ZA3 SS701H-1ZA4	SS1A1H-1ZA3 SS1A1H-1ZA4	SS1F1H-1ZA3 SS1F1H-1ZA4	SS2A1H-1ZA3 SS2A1H-1ZA4
Main circuit	Rated voltage			
	200 - 480V AC 50/60Hz			
	Rated thermal current (A)*	70	100	150
	Max. heater capacity (kW) Single phase 400V AC	28	40	60
Number of elements				Single-pole, 1-element
Control circuit	Isolation method			
	Photocoupler			
	Control voltage Vn			
	A3: 100 – 120V AC, A4: 200 – 240V AC			
Pick-up voltage				85% Vn or less
Drop-out voltage				35% Vn and over
Operating time (at 100% Vn)				30ms or less
Release time (at 100% Vn)				30ms or less
Auxiliary circuit	Output			
	Thyristor 1NO			
Rated current and voltage				A3: 50mA, 120V AC A4: 50mA, 240V AC

##### DC control voltage

Type	SS701H-3Z-D3	SS1001H-3Z-D3	SS1501H-3Z-D3	SS2001H-3Z-D3
Ordering code	SS701H-3ZD3	SS1A1H-3ZD3	SS1F1H-3ZD3	SS2A1H-3ZD3
Main circuit	Rated voltage			
	200 - 480V AC 50/60Hz			
	Rated thermal current (A)*	70	100	150
	Max. heater capacity (kW) Single phase 400V AC	28	40	60
Number of elements				Single-pole, 1-element
Control circuit	Isolation method			
	Photocoupler			
	Control voltage Vn			
	5 — 24V DC			
Pick-up voltage				3.5V or less
Drop-out voltage				1V and over
Operating time (at 100% Vn)				15ms or less
Release time (at 100% Vn)				15ms or less
Auxiliary circuit	-			

Note: \* The values are the maximum ratings of type with cooling fin that apply at an ambient temperature not exceeding 40°C.

##### 3-pole unit type

##### ● Main circuit 240V AC, SS03 to SS120

Type *1	SS □ □ -1(Z)-A3, A4, D5SS □ □ -1(Z)-A1, D2		SS □ □ -1M(Z)A1, D2						
Ordering code *1	SS □ □ -1M(Z)A3, A4, D5		SS □ □ -1M(Z)A1, D2						
Main circuit	Rated voltage		100 - 240V AC 50/60Hz			100 - 240V AC 50/60Hz			
	Rated thermal current (A)	3	8	20	30	40	50	80	120
	Max. heater capacity (kW)	1.0	2.5	6.9	10.3	13.8	17.3	27.7	41.5
	Max. motor capacity (kW) *2	0.2	0.4	0.75	1.5	2.2	3.7	7.5	7.5
	Motor full load current (A)	1.8	3.2	4.8	8	11.1	17.4	34	34
	3-phase 200V AC								
	Number of elements		3-pole, 2 or 3-element *3						
Control circuit	Isolation method		Photocoupler						
	Control voltage (Vn)		A3: 100–120V AC 50/60Hz A4: 200–240V AC 50/60Hz D5: 12–24V DC			A1: 100–120/200–240V AC 50/60Hz D2: 12/24V DC			
	Pick-up voltage		85% Vn or less 8V or less(D5)			85% Vn or less			
	Drop-out voltage		30% Vn and over 1V and over(D5)			30% Vn and over			
Operating time (at 100% Vn)		30ms or less							
Release time (at 100% Vn)		30ms or less							
Auxiliary circuit	Output		AC operated Thyristor 1NO					Thyristor 2NO	
	DC operated		Transistor 1NO					Transistor 2NO	
	Rated current and voltage		AC operated 50mA, 240V AC			0.2A, 240V AC			DC operated 0.1A, 24V DC
					0.2A, 24V DC				

Note: \*1, \*2, \*3 see page 01/113.

■ Specifications

3-pole unit types

● Main circuit 240V AC, SS03 to SS120

Type <sup>*1</sup>	SS□■-3(Z)-D5, D6				SS□■-3(Z)-D3				
Ordering code <sup>*1</sup>	SS□■-3M(Z)D5, D6				SS□■-3M(Z)D3				
Main circuit	Rated voltage	100 - 240V AC 50/60Hz							
	Rated thermal current (A)	3	8	20	30	40	50	80	120
	Max. heater capacity (kW)	1.0	2.5	6.9	10.3	13.8	17.3	27.7	41.5
	Max. motor capacity (kW) <sup>*2</sup>	0.2	0.4	1.5	2.2	3.7	5.5	7.5	7.5
	Motor full load current (A)	1.8	3.2	8	11.1	17.4	26	34	34
	3-phase 200V AC								
	Number of elements	3-pole, 2 or 3-element <sup>*3</sup>							
Control circuit	Isolation method	Photocoupler							
	Control voltage (Vn)	D5: 12–24V DC D6: 5V DC				D3: 5–24V DC			
	Pick-up voltage	D5: 8V or less D6: 4V or less				D3: 3.5V or less			
	Drop-out voltage	D5, D6: 1V and over				D3: 1.5V and over			
	Operating time (at 100% Vn) Release time (at 100% Vn)	5ms or less (SS□-3Z: 15ms or less) 15ms or less							
Auxiliary circuit	AC operated type	—							
	DC operated type	—							

Notes: <sup>\*1</sup> Replace the □ mark by rated thermal current code (03 to 200), and the ■ mark by the number of elements (2 or 3). See page 01/132,133.

<sup>\*2</sup> Maximum ratings when SSC is used with cooling fin (SX1-□) at temperature of 40°C or less.

Motor starting current: 6 times full-load current, Motor starting time: 0.25s or less.

<sup>\*3</sup> 2-element types are supplied in 3-pole with current carrying parts omitted from center pole.

● Main circuit 480V AC, SS30H to SS120H

Type <sup>*1</sup>	SS□■H-1(Z)-A1, D2				SS□■H-3(Z)-D3				
Ordering code <sup>*1</sup>	SS□■H-1M(Z)A1, D2				SS□■H-3M(Z)D3				
Main circuit	Rated voltage	200 - 480V AC 50/60Hz							
	Rated thermal current (A)	30	50	80	120	30	50	80	120
	Max. heater capacity (kW)	20.7	34.6	55.4	83.0	20.7	34.6	55.4	83.0
	Max. motor capacity (kW) <sup>*2</sup>	7.5	11	22	22	7.5	11	22	22
	Motor full load current (A)	17	24	48	48	17	24	48	48
	3-phase 400V AC								
	Number of elements	3-pole, 2 or 3-element <sup>*3</sup>				3-pole, 2 or 3-element <sup>*3</sup>			
Control circuit	Isolation method	Photocoupler							
	Control voltage (Vn)	A1: 100–120/200–240V AC 50/60Hz D2: 12/24V DC				5–24V DC			
	Pick-up voltage	85% Vn or less				3.5V or less			
	Drop-out voltage	30% Vn and over				1.5V and over			
	Operating time (at 100% Vn) Release time (at 100% Vn)	30ms or less 30ms or less				5ms or less (SS□H-3Z: 15ms or less) 15ms or less			
Auxiliary circuit	Output	AC operated	Thyristor 2NO			—			
	DC operated	DC operated	Transistor 2NO			—			
	Rated current and voltage	AC operated	0.2A, 240V AC			—			
		DC operated	0.2A, 24V DC			—			

Notes: <sup>\*1</sup> Replace the □ mark by rated thermal current code (03 to 200), and the ■ mark by the number of elements (2 or 3). See page 01/132,133.

<sup>\*2</sup> Maximum ratings when SSC is used with cooling fin (SX1-□) at temperature of 40°C or less.

Motor starting current: 6 times full-load current, Motor starting time: 0.25s or less.

<sup>\*3</sup> 2-element types are supplied in 3-pole with current carrying parts omitted from center pole.

# Solid-state Contactors

## SS series

### General use

#### ■ Specifications

#### 3-pole independent type

#### ● Main circuit 240V AC, SS03-4 to SS120-4

Type *1	SS□■-4(Z)-A3	SS□■-4(Z)-A4	SS□■-4(Z)-D3	SS□■-4(Z)-D5	SS□■-4(Z)-D6
Ordering code *1	SS□■-4M(Z)A3	SS□■-4M(Z)A4	SS□■-4M(Z)D3	SS□■-4M(Z)D5	SS□■-4M(Z)D6
Main circuit	Rated voltage				
	100 - 240V AC 50/60Hz				
	Rated thermal current (A)				
	20 30 40 50 80 120 3 8 3 8				
Max. heater capacity (kW)					
4 6 8 10 16 24 0.6 1.6 0.6 1.6					
Single phase 200V AC					
Number of elements					
3-pole, 2 or 3-element *3					
Control circuit	Isolation method				
	Photocoupler				
	Control voltage (Vn)				
	100-120V AC 200-240V AC 5-24V DC 12-24V DC 5V DC				
	Pick-up voltage				
85% Vn or less 3.5V or less 8V or less 4V or less					
Drop-out voltage					
30%Vn and over 1.5V and over 1V and over 1V and over					
Operating time (at 100% Vn)					
30ms or less 5ms or less (D3: SS□■-4Z: 15ms or less)					
Release time (at 100% Vn)					
30ms or less 15ms or less					
Auxiliary circuit	—				

#### ● Main circuit 480V AC, SS30H-4 to SS120H-4

Type *1	SS□■H-4(Z)-A3	SS□■H-4(Z)-A4	SS□■H-4(Z)-D3
Ordering code *1	SS□■H-4M(Z)A3	SS□■H-4M(Z)A4	SS□■H-4M(Z)D3
Main circuit	Rated voltage		
	200 - 480V AC 50/60Hz		
	Rated thermal current (A)		
	30 50 80 120		
Max. heater capacity (kW)			
12 20 32 48			
Single phase 400V AC			
Number of elements			
3-pole, 2 or 3-element *3			
Control circuit	Isolation method		
	Photocoupler		
	Control voltage (Vn)		
	100-120V AC 200-240V AC 5-24V DC		
	Pick-up voltage		
85% Vn or less 3.5V or less			
Drop-out voltage			
30% Vn and over 1.5V and over			
Operating time (at 100% Vn)			
30ms or less 5ms or less (SS□■H-4Z: 15ms or less)			
Release time (at 100% Vn)			
30ms or less 15ms or less			
Auxiliary circuit	—		

Notes: \*1 Replace the □ mark by rated thermal current code (03 to 200) and the ■ mark by the number of elements (2 or 3). See page 01/132, 133.

\*2 Maximum ratings when SSC is used with cooling fin (SX1-□) at temperature of 40°C or less.

\*3 2-element types are supplied in 3-pole with current carrying parts omitted from center pole.

● **3-pole AC operated**

Type Main circuit 240V AC: <b>Blank</b> 480V AC: <b>H</b> 3-pole 2-element	3-pole 3-element	Control circuit										
		3-pole unit type: 1						3-pole independent type: 4				
		Zero-cross function										
		Provided: <b>Z</b>			Not provided: <b>Blank</b>			Provided: <b>Z</b>		Not provided: <b>Blank</b>		
Control voltage: 100-120V AC/200-220V AC: <b>A1</b> , 100-120V AC: <b>A3</b> , 200-240V AC: <b>A4</b>												
A1			A3			A4			A3		A4	
With cooling fin: F					With cooling fin: F							
SS032	SS033		●	●		●	●					
SS082	SS083		●	●		●	●					
SS202	SS203	●			●			●	●	●	●	
SS302	SS303	●			●			●	●	●	●	
SS302H	SS303H	●			●			●	●	●	●	
SS402	SS403	●			●			●	●	●	●	
SS502	SS503	●			●			●	●	●	●	
SS502H	SS503H	●			●			●	●	●	●	
SS802	SS803	●			●			●	●	●	●	
SS802H	SS803H	●			●			●	●	●	●	
SS1202	SS1203	●			●			●	●	●	●	
SS1202H	SS1203H	●			●			●	●	●	●	

Note: ● Available

● **3-pole DC operated**

Type Main circuit 240V AC: <b>Blank</b> 480V AC: <b>H</b> 3-pole 2-element	3-pole 3-element	Control circuit																											
		3-pole unit type: 1						3-pole unit type: 3						3-pole independent type: 4															
		Zero-cross function																											
		Z			Blank			Z			Blank			Z			Blank												
Control voltage: 12/24V DC: <b>D2</b> , 5-24V DC: <b>D3</b> , 12-24V DC: <b>D5</b> , 5V DC: <b>D6</b>																													
D2			D5			D2			D5			D3			D5			D6			D3			D5			D6		
With cooling fin: F									With cooling fin: F																				
SS032	SS033		●		●		●	●		●	●		●	●		●	●	●	●		●	●		●	●				
SS082	SS083		●		●		●	●		●	●		●	●		●	●	●	●		●	●		●	●				
SS202	SS203	●		●		●			●			●			●			●		●									
SS302	SS303	●		●		●			●			●			●			●		●									
SS302H	SS303H	●		●		●			●			●			●			●		●									
SS402	SS403	●		●		●			●			●			●			●		●									
SS502	SS503	●		●		●			●			●			●			●		●									
SS502H	SS503H	●		●		●			●			●			●			●		●									
SS802	SS803	●		●		●			●			●			●			●		●									
SS802H	SS803H	●		●		●			●			●			●			●		●									
SS1202	SS1203	●		●		●			●			●			●			●		●									
SS1202H	SS1203H	●		●		●			●			●			●			●		●									

Note: ● Available

# Solid-state Contactors

## SS series

### General use

#### ■ Type number nomenclature

##### ● Single-pole type

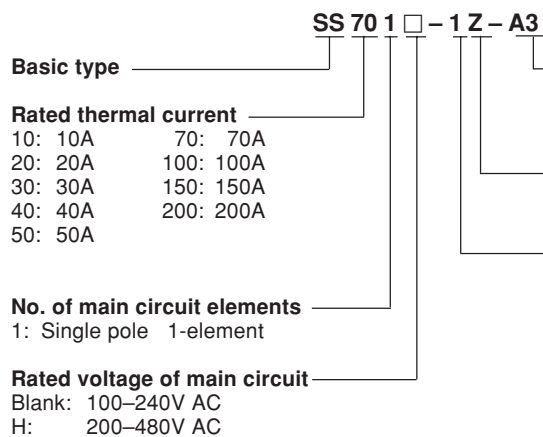

#### Control voltage

A3: 100–120V AC  
A4: 200–240V AC  
D3: 5–24V DC

#### Zero-cross function

Z: Provided

#### Control circuit

	Isolation method	Voltage detector	Auxiliary contact	Applicable contactor	
1	Photocoupler	Provided	Provided	SS701 to 2001	240V AC
				SS701H to 2001H	480V AC
3	Photocoupler	Not provided	Not provided	SS101 to 2001	240V AC
				SS701H to 2001H	480V AC
5	Photocoupler	Not provided	Not provided	SS101 to 501	240V AC

##### ● 3-pole type

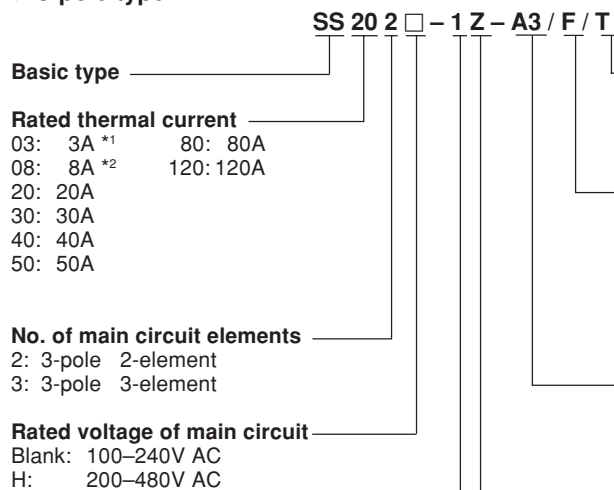

#### Terminal cover

Blank: Not provided  
T: Provided (only for SS202 to SS502, SS203 to SS503 of main circuit voltage 200V)

#### Shipping form

F: Contactor and cooling fin set  
F-A3: Contactor and cooling fin set \*3  
F-A4: Contactor and cooling fin set \*4  
F-D5: Contactor and cooling fin set \*5  
Blank: Contactor only  
(Cooling fin sold separately)

#### Control voltage

A1: 100–120/200–220V AC      D2: 12/24V DC  
A3: 100–120V AC      D3: 5–24V DC  
A4: 200–240V AC      D5: 12–24V DC  
D6: 5V DC

#### Zero-cross function

Blank: Not provided  
Z: Provided

#### Control circuit

	Control method		Isolation method	Voltage detector	Auxiliary contact
	3-pole unit	3-pole independent			
1	○		Photocoupler	Provided	Provided
3	○		Photocoupler	Not provided	Not provided
4		○	Photocoupler	Not provided	Not provided

Notes: \*1 Type SS03□ can carry the rated thermal current even if no cooling fin is fitted.

\*2 Type SS08□ is shipped with a cooling fin fitted to the main body even if /F is not suffixed to the type number.

\*3 Suffix code applicable only to type SS80□ and type SS120□. Fan rated operating voltage: 100–120V AC, 50/60Hz.

\*4 Suffix code applicable only to type SS80□ and type SS120□. Fan rated operating voltage: 200–240V AC, 50/60Hz.

\*5 Suffix code applicable only to type SS80□ and type SS120□. Fan rated operating voltage: 24V DC.



■ Ordering code system

S S 8 0 3 H — 1 Z A 1 F A 3  
① ② ③ ④ ⑤ ⑥ ⑦ ⑧ ⑨ ⑩ ⑪ ⑫ ⑬

① Product category

Description	Code
Contactors	S

② Series category

Description	Code
Solid-state contactor	S

③④ Framesize

Frame size	Code	
	③	④
03	0	3
08	0	8
10	1	0
20	2	0
30	3	0
40	4	0
50	5	0
70	7	0
80	8	0
100	1	A
120	1	C
150	1	F
200	2	A

⑤ No. of main circuit elements

No. of elements	Code
Single pole, 1-element	1
3-pole, 2-element	2
3-pole, 3-element	3

■ Versions

Single-pole type

● Main circuit 240V AC

Control voltage	Voltage detector	Auxiliary contact	Zero-cross function	Rated thermal current				
				10A	20A	30A	40A	50A
100-120V AC	—	—	●	SS101-5Z-A3	SS201-5Z-A3	SS301-5Z-A3	SS401-5Z-A3	SS501-5Z-A3
200-240V AC	—	—	●	SS101-5Z-A4	SS201-5Z-A4	SS301-5Z-A4	SS401-5Z-A4	SS501-5Z-A4
5-24V DC	—	—	●	SS101-3Z-D3	SS201-3Z-D3	SS301-3Z-D3	SS401-3Z-D3	SS501-3Z-D3

Control voltage	Voltage detector	Auxiliary contact	Zero-cross function	Rated thermal current			
				70A	100A	150A	200A
100-120V AC	●	●	●	SS701-1Z-A3	SS1A1-1Z-A3	SS1F1-1Z-A3	SS2A1-1Z-A3
200-240V AC	●	●	●	SS701-1Z-A4	SS1A1-1Z-A4	SS1F1-1Z-A4	SS2A1-1Z-A4
5-24V DC	—	—	●	SS701-3Z-D3	SS1A1-3Z-D3	SS1F1-3Z-D3	SS2A1-3Z-D3

● Main circuit 480V AC

Control voltage	Voltage detector	Auxiliary contact	Zero-cross function	Rated thermal current			
				70A	100A	150A	200A
100-120V AC	●	●	●	SS701H-1Z-A3	SS1A1H-1Z-A3	SS1F1H-1Z-A3	SS2A1H-1Z-A3
200-240V AC	●	●	●	SS701H-1Z-A4	SS1A1H-1Z-A4	SS1F1H-1Z-A4	SS2A1H-1Z-A4
5-24V DC	—	—	●	SS701H-3Z-D3	SS1A1H-3Z-D3	SS1F1H-3Z-D3	SS2A1H-3Z-D3

Note: ● Provided — Not provided

⑥ Rated voltage of main circuit

Rated voltage	Code
100-240V AC	Blank
200-480V AC	H

⑦ Control circuit

● 3-pole type

Control method	Insolation method	Voltage detector	Auxiliary contact	Code
3-pole unit	Photocoupler	Provided	Provided	1
3-pole unit	Photocoupler	Not provided	Not provided	3
3-pole independent	Photocoupler	Not provided	Not provided	4

● Single-pole type

Control method	Insolation method	Voltage detector	Auxiliary contact	Code
Single-pole	Photocoupler	Provided	Provided	1
	Photocoupler	Not provided	Not provided	3
	Photocoupler	Not provided	Not provided	5

⑧ Zero-cross function

Zero-cross function	Code	
	Single-pole	3-pole
Not provided	Blank	M
Provided	Z	Z

⑪ Shipping form

Description	Code	
	Single-pole	3-pole
Cooling fin set Contactor only	Blank	F
	Not provided	Blank

⑨⑩ Control voltage

Description	Code	
	⑨	⑩
100-120V/200-240V AC	A	1
100-120V AC	A	3
200-240V AC	A	4
12/24V DC	D	2
5-24 V DC	D	3
12-24V DC	D	5
5V DC	D	6

⑫⑬ Cooling fan voltage

Cooling fan control voltage	Code	
	⑫	⑬
100-120V AC	A	3
200-240V AC	A	4
12-24V DC	D	5

# Solid-state Contactors

## SS series

### General use

#### ■ Versions

#### 3-pole type

#### ● Main circuit 240V AC

Rated thermal current		3A	8A	20A	30A	40A	50A	80A	120A	
AC control voltage <sup>*1</sup>	2-element	SS032-1M□	SS082-1M□	SS202-1M□F SS202-4M□F	SS302-1M□F SS302-4M□F	SS402-1M□F SS402-4M□F	SS502-1M□F SS502-4M□F	SS802-1M□F■ SS802-4M□F■	SS1C2-1M□F■ SS1C2-4M□F■	
	(With zero-cross function)	SS032-1Z□	SS082-1Z□	SS202-1Z□F SS202-4Z□F	SS302-1Z□F SS302-4Z□F	SS402-1Z□F SS402-4Z□F	SS502-1Z□F SS502-4Z□F	SS802-1Z□F■ SS802-4Z□F■	SS1C2-1Z□F■ SS1C2-4Z□F■	
	3-element	SS033-1M□	SS083-1M□	SS203-1M□F SS203-4M□F	SS303-1M□F SS303-4M□F	SS403-1M□F SS403-4M□F	SS503-1M□F SS503-4M□F	SS803-1M□F■ SS803-4M□F■	SS1C3-1M□F■ SS1C3-4M□F■	
	(With zero-cross function)	SS033-1Z□	SS083-1Z□	SS203-1Z□F SS203-4Z□F	SS303-1Z□F SS303-4Z□F	SS403-1Z□F SS403-4Z□F	SS503-1Z□F SS503-4Z□F	SS803-1Z□F■ SS803-4Z□F■	SS1C3-1Z□F■ SS1C3-4Z□F■	
	DC control voltage <sup>*2</sup>	2-element	SS032-1M□ SS032-3M□ SS032-4M□	SS082-1M□ SS082-3M□ SS082-4M□	SS202-1M□F SS202-3M□F SS202-4M□F	SS302-1M□F SS302-3M□F SS302-4M□F	SS402-1M□F SS402-3M□F SS402-4M□F	SS502-1M□F SS502-3M□F SS502-4M□F	SS802-1M□F■ SS802-3M□F■ SS802-4M□F■	SS1C2-1M□F■ SS1C2-3M□F■ SS1C2-4M□F■
		(With zero-cross function)	SS032-1Z□ SS032-3Z□ SS032-4Z□	SS082-1Z□ SS082-3Z□ SS082-4Z□	SS202-1Z□F SS202-3Z□F SS202-4Z□F	SS302-1Z□F SS302-3Z□F SS302-4Z□F	SS402-1Z□F SS402-3Z□F SS402-4Z□F	SS502-1Z□F SS502-3Z□F SS502-4Z□F	SS802-1Z□F■ SS802-3Z□F■ SS802-4Z□F■	SS1C2-1Z□F■ SS1C2-3Z□F■ SS1C2-4Z□F■
3-element		SS033-1M□ SS033-3M□ SS033-4M□	SS083-1M□ SS083-3M□ SS083-4M□	SS203-1M□F SS203-3M□F SS203-4M□F	SS303-1M□F SS303-3M□F SS303-4M□F	SS403-1M□F SS403-3M□F SS403-4M□F	SS503-1M□F SS503-3M□F SS503-4M□F	SS803-1M□F■ SS803-3M□F■ SS803-4M□F■	SS1C3-1M□F■ SS1C3-3M□F■ SS1C3-4M□F■	
(With zero-cross function)		SS033-1Z□ SS033-3Z□ SS033-4Z□	SS083-1Z□ SS083-3Z□ SS083-4Z□	SS203-1Z□F SS203-3Z□F SS203-4Z□F	SS303-1Z□F SS303-3Z□F SS303-4Z□F	SS403-1Z□F SS403-3Z□F SS403-4Z□F	SS503-1Z□F SS503-3Z□F SS503-4Z□F	SS803-1Z□F■ SS803-3Z□F■ SS803-4Z□F■	SS1C3-1Z□F■ SS1C3-3Z□F■ SS1C3-4Z□F■	

Note: Enter the cooling fan voltage code in the ■ mark, [see page 01/133](#).

#### ● Main circuit 480V AC

Rated thermal current		30A	50A	80A	120A	
AC control voltage <sup>*1</sup>	2-element	SS302H-1M□F SS302H-4M□F	SS502H-1M□F SS502H-4M□F	SS802H-1M□F■ SS802H-4M□F■	SS1C2H-1M□F■ SS1C2H-4M□F■	
	(With zero-cross function)	SS302H-1Z□F SS302H-4Z□F	SS502H-1Z□F SS502H-4Z□F	SS802H-1Z□F■ SS802H-4Z□F■	SS1C2H-1Z□F■ SS1C2H-4Z□F■	
	3-element	SS303H-1M□F SS303H-4M□F	SS503H-1M□F SS503H-4M□F	SS803H-1M□F■ SS803H-4M□F■	SS1C3H-1M□F■ SS1C3H-4M□F■	
	(With zero-cross function)	SS303H-1Z□F SS303H-4Z□F	SS503H-1Z□F SS503H-4Z□F	SS803H-1Z□F■ SS803H-4Z□F■	SS1C3H-1Z□F■ SS1C3H-4Z□F■	
	DC control voltage <sup>*2</sup>	2-element	SS302H-1M□F SS302H-3M□F SS302H-4M□F	SS502H-1M□F SS502H-3M□F SS502H-4M□F	SS802H-1M□F■ SS802H-3M□F■ SS802H-4M□F■	SS1C2H-1M□F■ SS1C2H-3M□F■ SS1C2H-4M□F■
		(With zero-cross function)	SS302H-1Z□F SS302H-3Z□F SS302H-4Z□F	SS502H-1Z□F SS502H-3Z□F SS502H-4Z□F	SS802H-1Z□F■ SS802H-3Z□F■ SS802H-4Z□F■	SS1C2H-1Z□F■ SS1C2H-3Z□F■ SS1C2H-4Z□F■
3-element		SS303H-1M□F SS303H-3M□F SS303H-4M□F	SS503H-1M□F SS503H-3M□F SS503H-4M□F	SS803H-1M□F■ SS803H-3M□F■ SS803H-4M□F■	SS1C3H-1M□F■ SS1C3H-3M□F■ SS1C3H-4M□F■	
(With zero-cross function)		SS303H-1Z□F SS303H-3Z□F SS303H-4Z□F	SS503H-1Z□F SS503H-3Z□F SS503H-4Z□F	SS803H-1Z□F■ SS803H-3Z□F■ SS803H-4Z□F■	SS1C3H-1Z□F■ SS1C3H-3Z□F■ SS1C3H-4Z□F■	

#### Notes:

Control voltage (Refer to [page 01/133, 134](#).)

\*1 Replace the □ mark in the order number by the control voltage codes shown below.

A1	100–120/200–240V AC
A3	100–120V AC
A4	200–240V AC

\*2 Replace the □ mark in the order number by the control voltage codes shown below.

D2	12/24V DC
D3	5–24V DC
D5	12–24V DC
D6	5V DC

Note: Enter the cooling fan voltage code in the ■ mark, [see page 01/133](#).

■ Dimensions, mm  
Single-pole type

● SS101

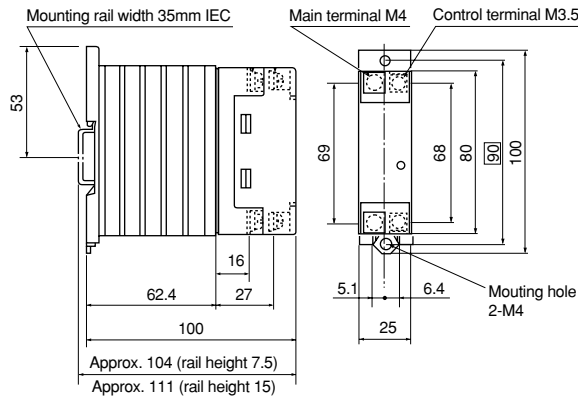

● SS201

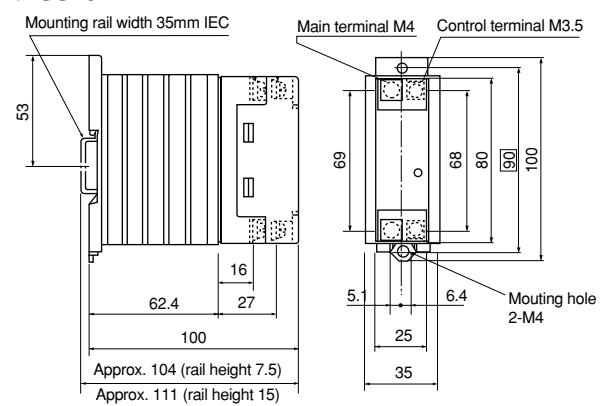

● SS301, 401

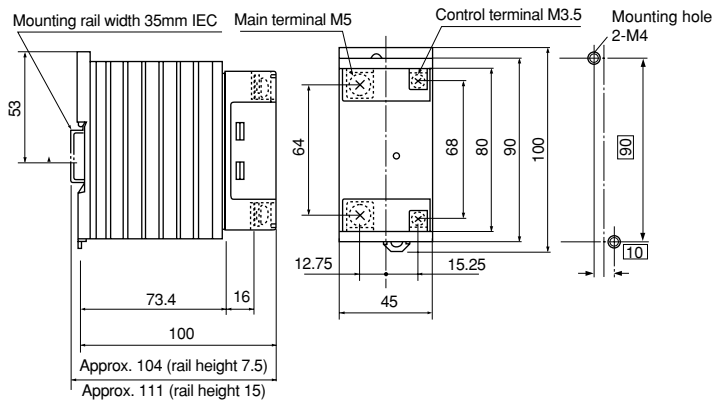

● SS501

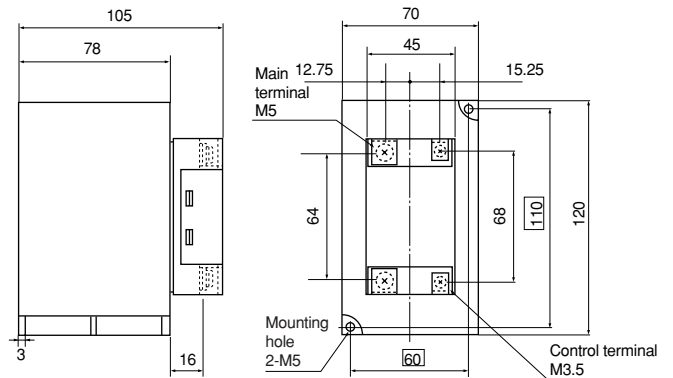

Mass:  
SS101: 0.22kg SS401: 0.36kg  
SS201: 0.24kg SS501: 0.66kg  
SS301: 0.36kg

● SS701

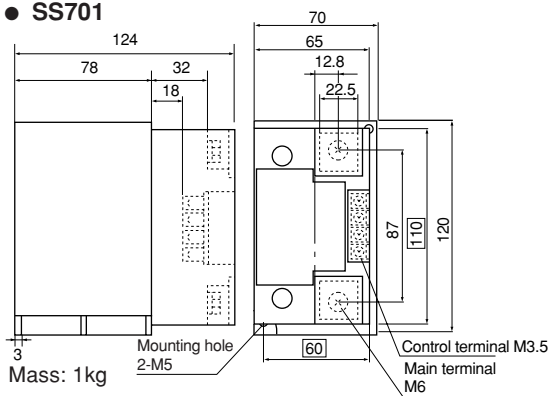

□ Mounting hole dimensions

● SS1001

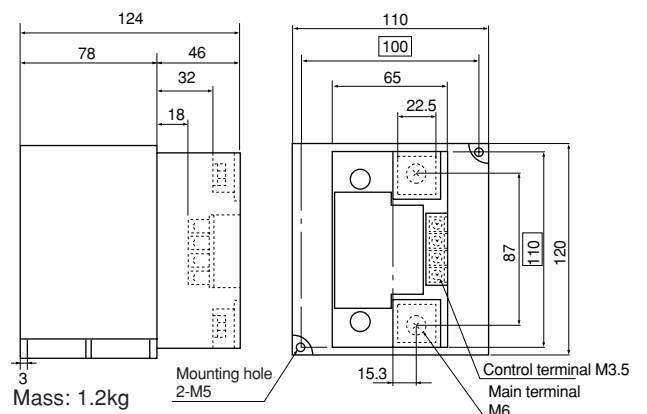

■ Wiring diagram

● SS101 to SS501

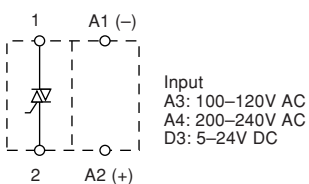

# Solid-state Contactors

## SS series

### General use

- Dimensions, mm
- Single-pole type
- SS1501

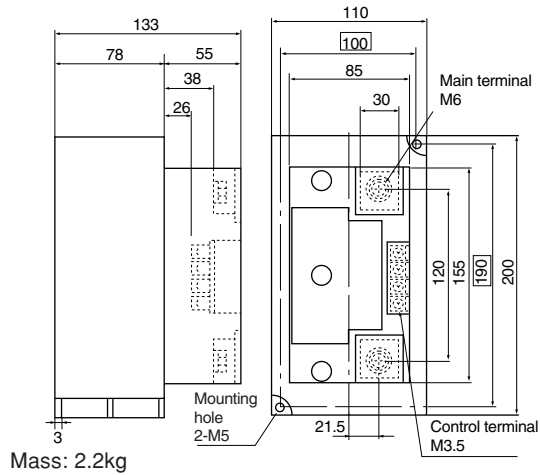

- SS2001

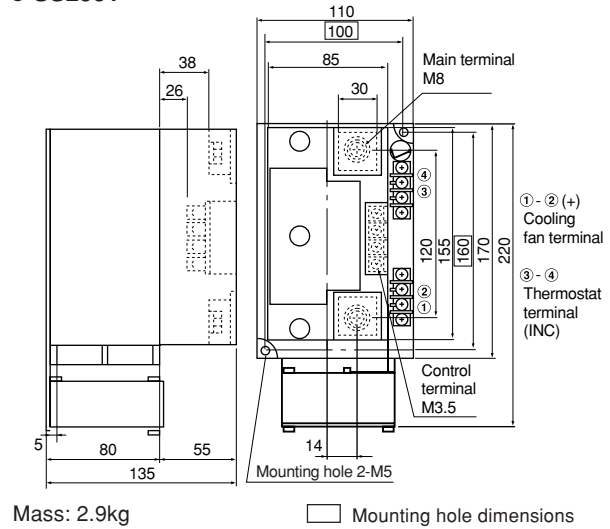

- Wiring diagrams
- SS701 to SS1501
- SS701H to SS1501H

Control input  
AC voltage

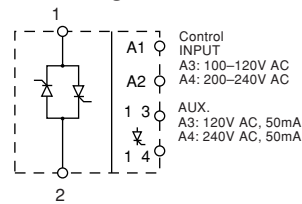

DC voltage

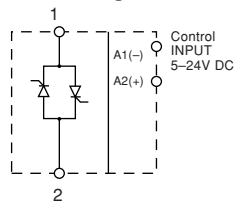

- SS2001, SS2001H

Control input  
AC voltage

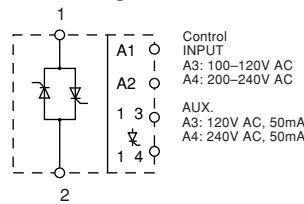

DC voltage

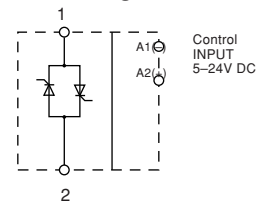

Internal

- ④ Thermostat terminal (NC)
- ③ (+) Cooling fan terminal
- ② (+) Cooling fan terminal
- ① (+) Cooling fan terminal

### Single pole type solid-state contactor

#### Application example

- Drive system
- Driven by relay contact

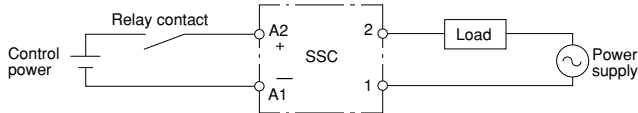

- Driven by NPN transistor

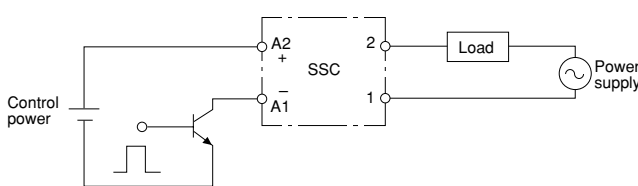

- Driven by PNP transistor

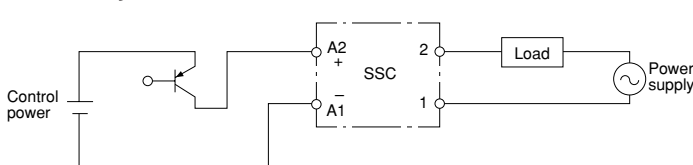

- Connection to load
- Heater control

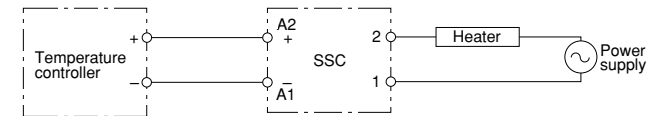

- Incandescent lamp

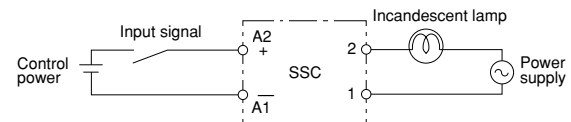

- 3-phase motor

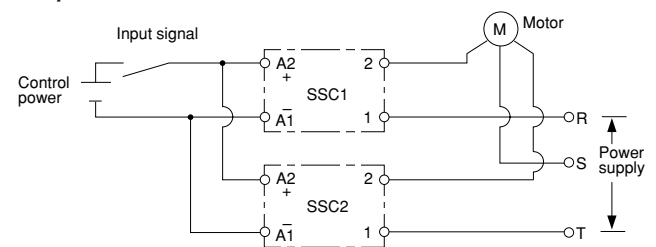

■ Dimensions, mm  
3-pole unit type

- SS03 (Rail mounting only)

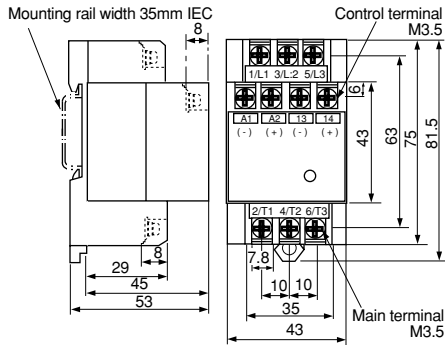

Mass: Approx. 0.18kg

- SS08

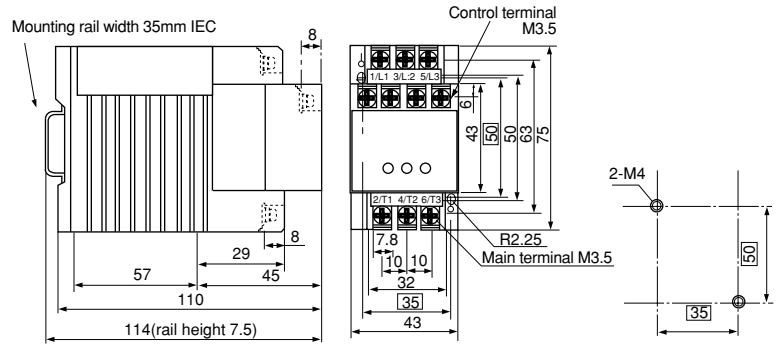

Mass: Approx. 0.3kg

- SS202, 203, 30

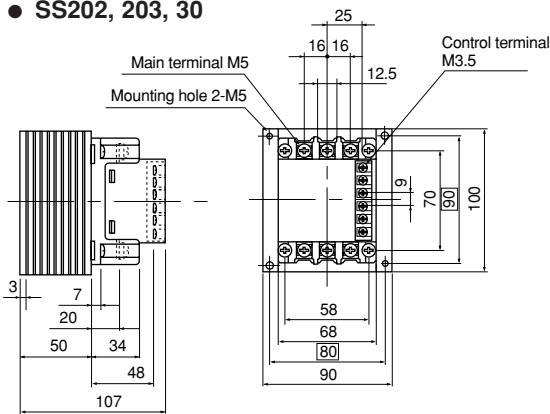

Mass: Approx. 0.77kg

- SS303, 403

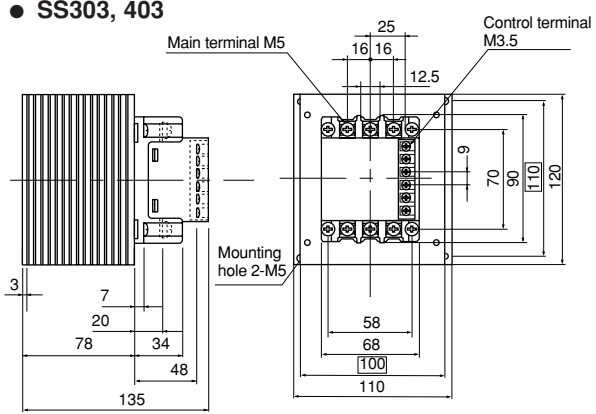

Mass: Approx. 1.1kg

- SS402

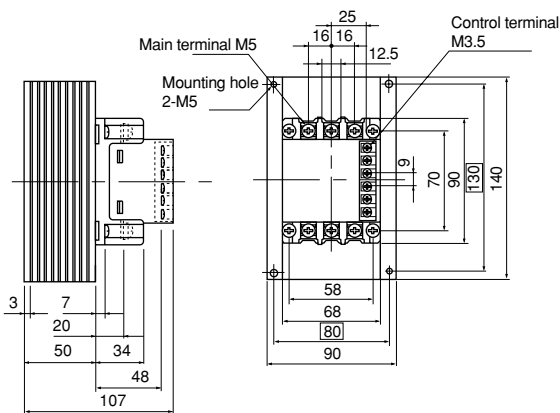

Mass: Approx. 0.99kg

- SS502

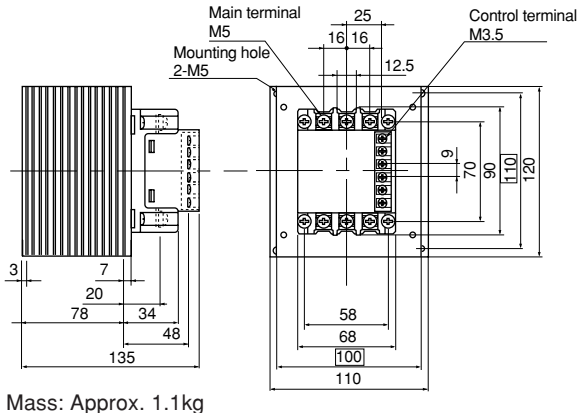

Mass: Approx. 1.1kg

□ Mounting hole dimensions

# Solid-state Contactors

## SS series

### General use

■ Dimensions, mm  
● SS503

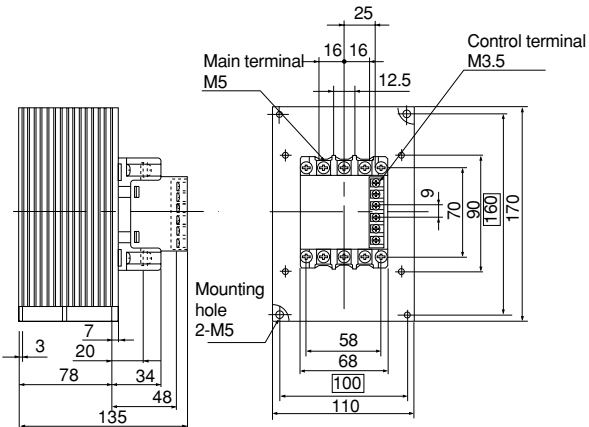

Mass: Approx. 1.6kg

● SS802, 803, 802H, 803H

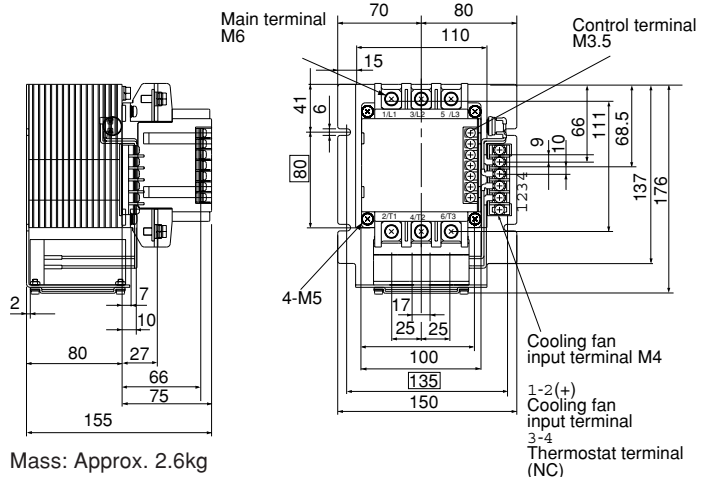

Mass: Approx. 2.6kg

● SS1202, 1203, 1202H, 1203H

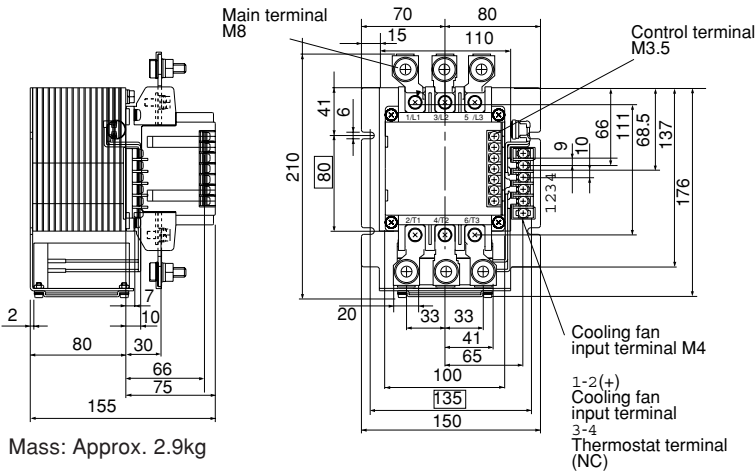

Mass: Approx. 2.9kg

● SS302H, 303H

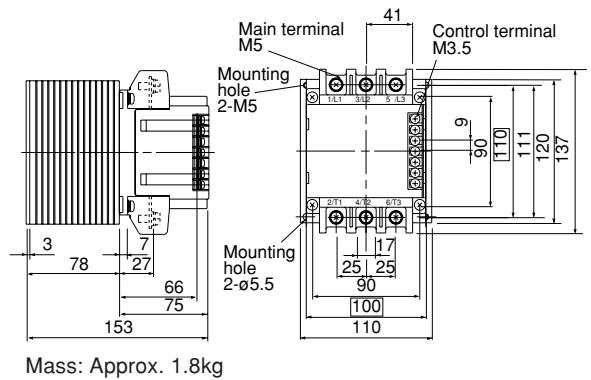

Mass: Approx. 1.8kg

● SS502H

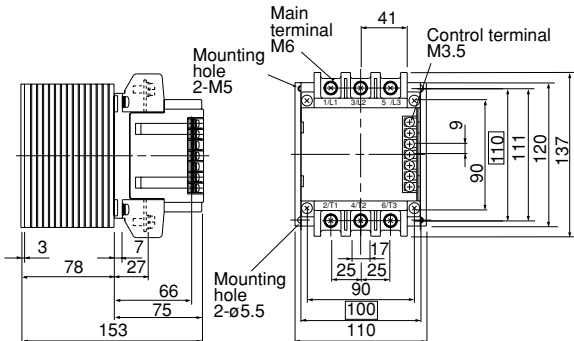

Mass: Approx. 1.8kg

● SS503H

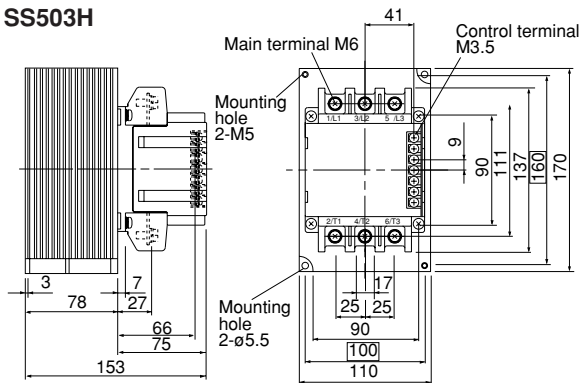

Mass: Approx. 2.2kg

□ Mounting hole dimensions

■ Dimensions, mm/Cooling fins  
● SX1-D10, SX1-D14

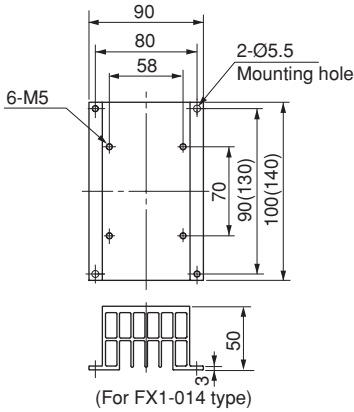

● SX1-E12

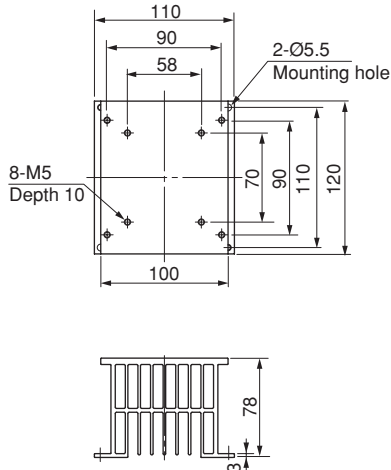

● SX1-E17

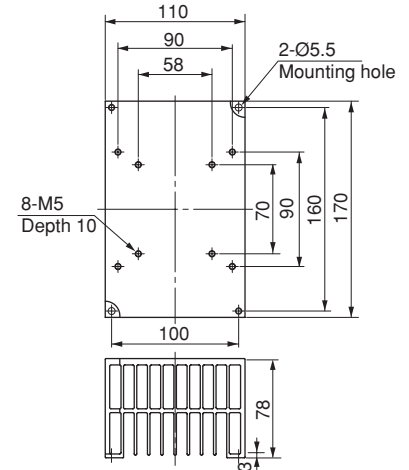

● SX1-C12

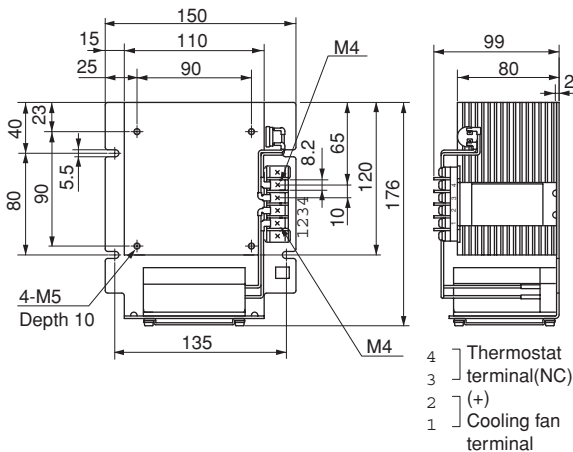

Type	Used with	Mass (kg)
SX1-D10	SS202, SS203, SS302	Approx. 0.36
SX1-D14	SS402	Approx. 0.53
SX1-E12	SS302H, SS303, SS303H SS403, SS502, SS502H	Approx. 0.82
SX1-E17	SS503, SS503H	Approx. 1.16
SX1-C12-A3	100-110V AC 50/60Hz SS802, SS802H, SS803	Approx. 2.2
SX1-C12-A4	200-220V DC 50/60Hz SS803H, SS1202, SS1202H	
SX1-C12-D5	24V DC SS1203, SS1203H	

■ Wiring diagrams  
● SS03, SS08/2-element

A1, A2, A3, C3, COM: Control terminals  
13, 14: Aux.terminals

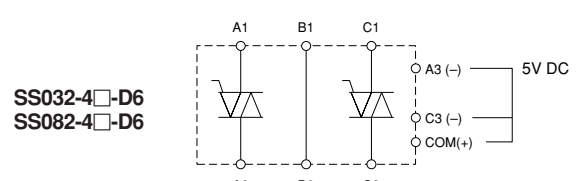
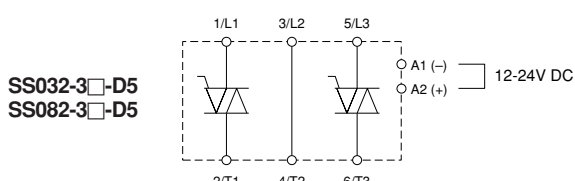
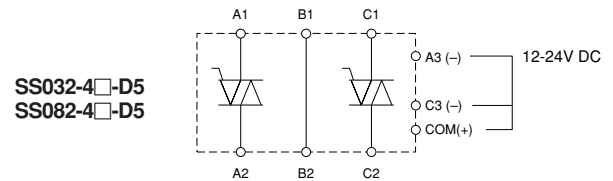
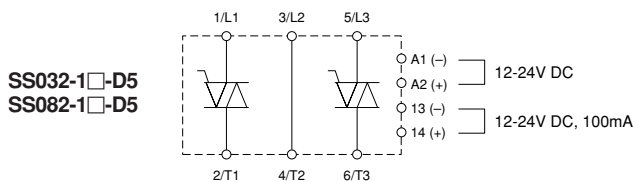
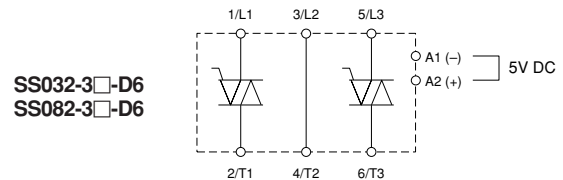
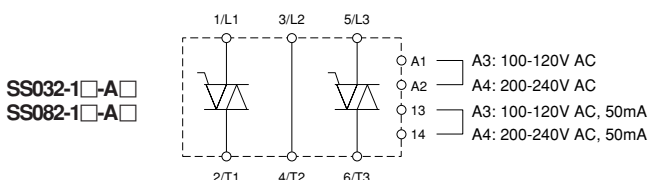

# Solid-state Contactors

## SS series

### General use

#### ■ Wiring diagrams

##### ● SS03, SS08/3-element

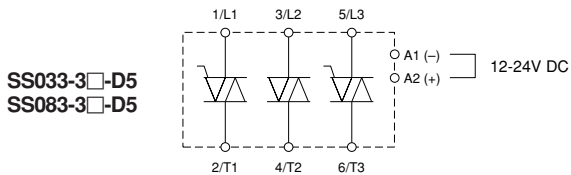
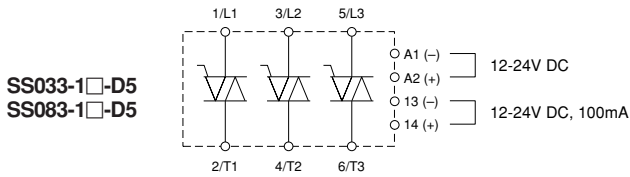
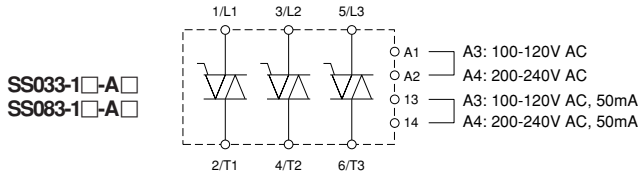

A1, A2, A3, B3, B4, C3, C4: Control terminals  
13, 14, 23, 24: Aux.terminals

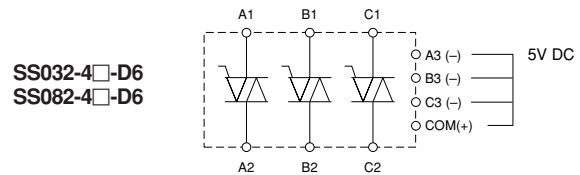
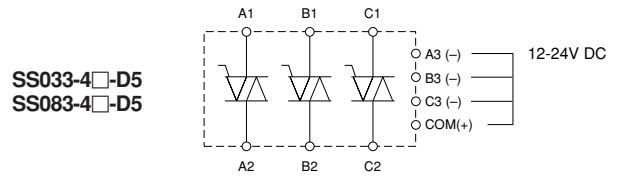
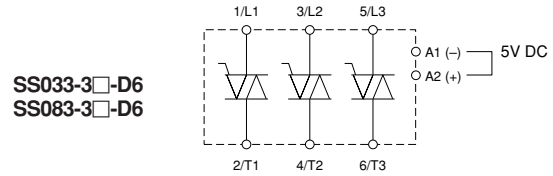

##### ● SS20, SS30, SS40, SS50, SS80, SS120 2-element

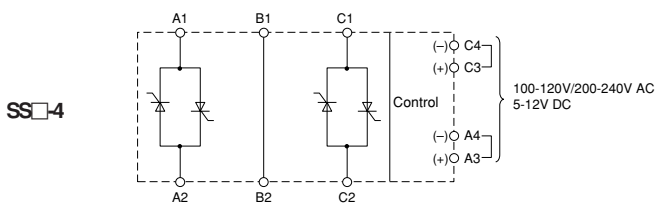
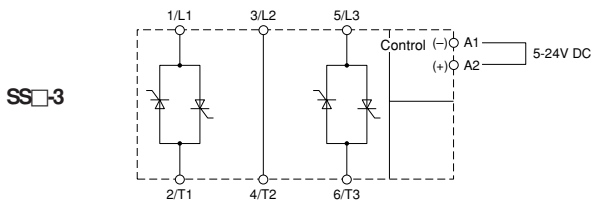
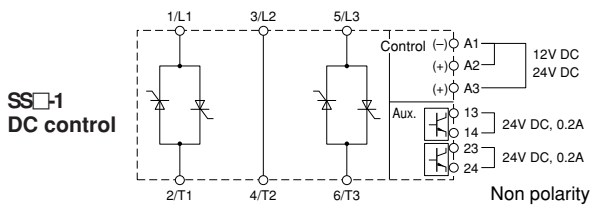
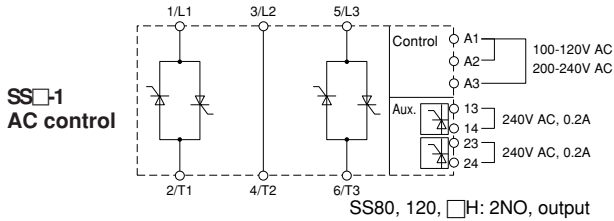

##### 3-element

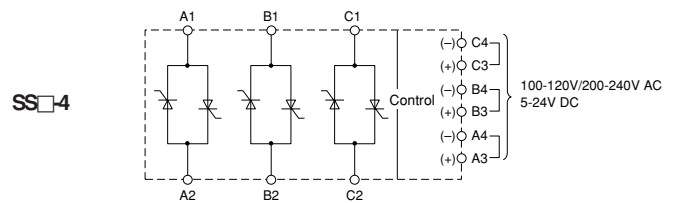
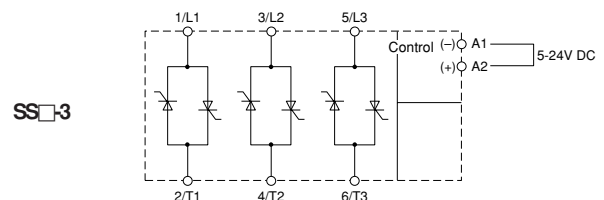
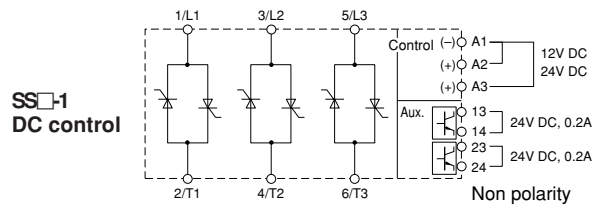
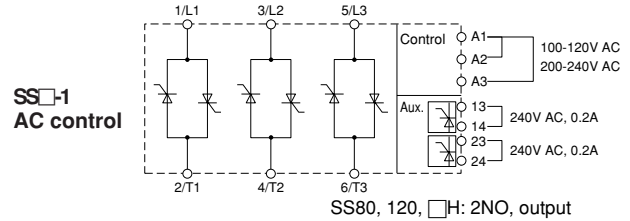

#### ■ Precautions for use

Be sure to read an Instruction Manual enclosed with the solid state relays before using in order to ensure proper operation.



**Solid-state contactors, Exclusively heater load use**

■ **Description**

These SSCs are compact and low in price, and applicable for heater switching.

■ **Features**

- Single-pole type
- Powerful line-up covering the output range of 10 to 30A, 240V AC
- Built-in surge suppressor (varistor) between output terminals
- Operation indication LED (red) equipped as standard for checking the input status of control voltage
- Terminal cover to prevent exposure of active terminals (optional)
- Dedicated cooling fin (optional)
- Standard models with UL and CSA approval.



■ **Type number nomenclature**

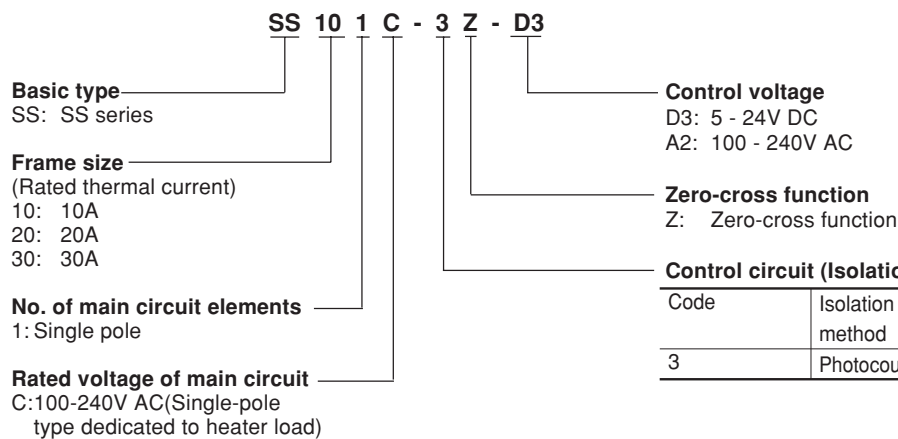

**Control circuit (Isolation method and function)**

Code	Isolation method	Voltage detector	Auxiliary contact
3	Photocoupler	Not provided	Not provided

■ **Types and ratings**

Rated thermal current *	Rated voltage of main circuit	Type	Ordering code	Voltage detection	Zero-cross function	Control circuit voltage	Impedance
10A	100 – 240V AC	<b>SS101C-3Z-D3</b>	SS101C-3ZD3	–	Provided	5 – 24V DC	4.8kΩ (at 24V)
		<b>SS101C-3Z-A2</b>	SS101C-3ZA2	–	Provided	100 – 240V AC	70kΩ (at 200V)
20A	100 – 240V AC	<b>SS201C-3Z-D3</b>	SS201C-3ZD3	–	Provided	5 – 24V DC	4.8kΩ (at 24V)
		<b>SS201C-3Z-A2</b>	SS201C-3ZA2	–	Provided	100 – 240V AC	70kΩ (at 200V)
30A	100 – 240V AC	<b>SS301C-3Z-D3</b>	SS301C-3ZD3	–	Provided	5 – 24V DC	4.8kΩ (at 24V)
		<b>SS301C-3Z-A2</b>	SS301C-3ZA2	–	Provided	100 – 240V AC	70kΩ (at 200V)

Note: \* The maximum rating when SSC is used with cooling fin.

# Solid-state Contactors

## SS series

### Heater load use

#### ■ Specifications

Type	SS□1C-3Z-D3			SS□1C-3Z-A2			
Main circuit	Rated operational voltage	100 to 240V AC					
	Operational voltage range	85 to 264V AC					
	Rated thermal current (I <sub>th</sub> )(AC-1) *	10A	20A	30A	10A	20A	30A
	Rated frequency	50/60Hz					
	Applicable heater capacity (1φ 200V)	2kW	4kW	6kW	2kW	4kW	6kW
	Minimum load current	100mA					
	Voltage drop (ON state) (max.)	1.6V					
	Leakage current (OFF state) (max.)	15mA					
	Non-repetitive surge on current (I <sub>TSM</sub> ) (Under 60Hz, sine wave, 1 cycle, rated load condition)	150A	225A	300A	150A	225A	300A
	Zero-cross function	Provided					
Surge suppressor (varistor)	Provided (between output terminals)						
Applicable cooling fin (Optional)	Fin type : SX1-H9B/X, I9B/X (rail-mounting/screw-mounting), SX1-100S, 200S (screw-mounting)						
Control circuit	Isolation method	Photocoupler			AC operated type (2 terminals, non polarity)		
		DC operated type (2 terminals, with polarity)					
	Rated operational voltage	5, 12, 24V DC			100 – 120/200 – 240V AC		
	Operational voltage range	4 to 30V DC			85 to 264V AC		
	Operational voltage	4V DC or less			85V AC or less		
	Reset voltage	1.5V DC and over			30V AC and over		
	Operation time (at 100%V <sub>n</sub> )	15ms or less			30ms or less		
	Reset time (at 100%V <sub>n</sub> )	15ms or less			30ms or less		
	Current consumption	7mA or less (at 30V DC)			5mA or less (at 264V AC)		
Operation indicator	LED (Red)						
Mass	Approx. 55g						
Approved by							

Note: \* The maximum rating when SSC is used with cooling fin.

#### ■ General specifications

Type	SS□1C-3Z-D3,-A2
Temperature range	-20 to +80°C (no icing)
Relative humidity	45 to 85% (no condensation)
Altitude	2,000m or less
Temperature-rise (100%I <sub>n</sub> , 100%V <sub>n</sub> )	Main circuit terminal, Control circuit terminal, Base...65°C or less
Dielectric strength	2,000V AC, 1 minute. : Between main circuits, between control circuit and base, between main circuit and control circuit.
Insulation resistance	100MΩ or more (500V DC megger) : Between main circuits, between control circuit and base, between main circuit and control circuit.
Vibration resistance	Mechanical durability: 10 to 55Hz, double amplitude 0.75mm
Shock resistance	Mechanical durability: 300m/s <sup>2</sup>

#### ■ Wiring

Terminal type	Terminal screw	Connectable wire size (maximum size of conductor)	Maximum width of crimp-type terminal (nominal size) *1 *2	Recommended tightening torque
Main circuit terminal	M4 cross-recessed slotted machine screw with square washer	1.25 to 5.5mm <sup>2</sup> φ2 to 3.2	9.7mm (R5.5-4)	1.2 to 1.5N·m
Control circuit terminal	M4 cross-recessed slotted machine screw with square washer	1.25 to 5.5mm <sup>2</sup> φ2 to 3.2	9.7mm (R5.5-4)	1.2 to 1.5N·m

Note: \*1 JIS C 2805 round crimp-type terminal

\*2 Prepare crimp-type terminals smaller than the specified maximum width.

■ Ambient temperature - Thermal current characteristics  
**SS101C-3Z-** □

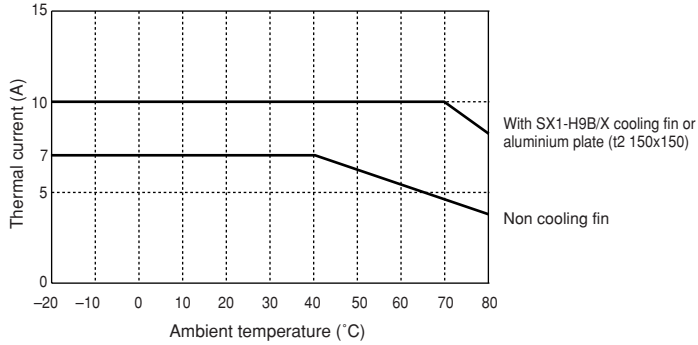

**SS201C-3Z-** □

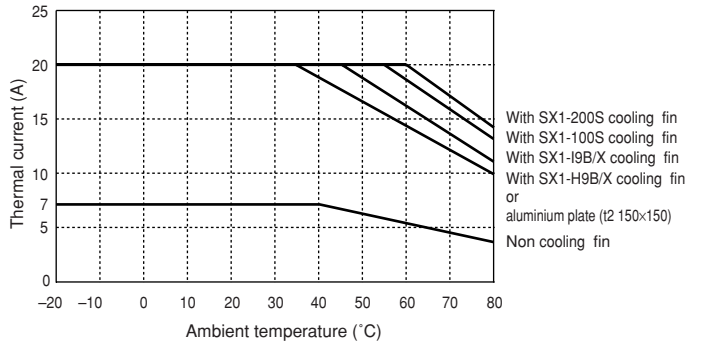

**SS301C-3Z-** □

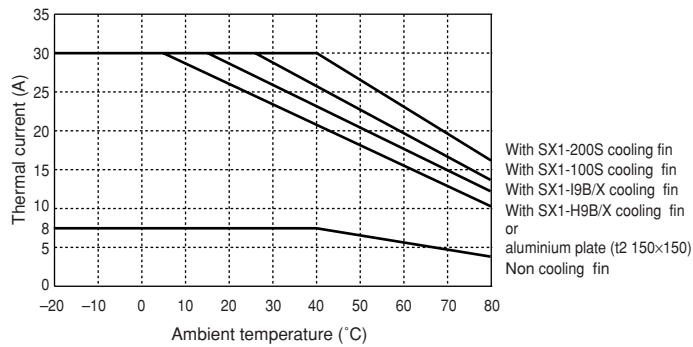

■ Control voltage - Current characteristic (Example)  
**DC input (SS □ 1C-3Z-D3 type)**

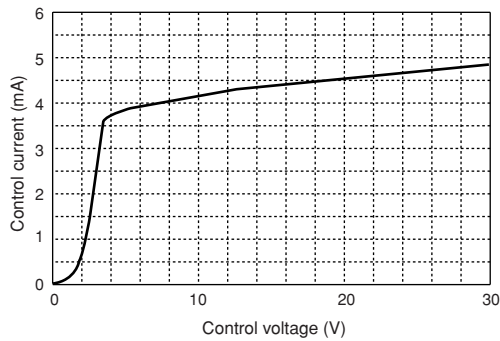

**AC input (SS □ 1C-3Z-A2 type)**

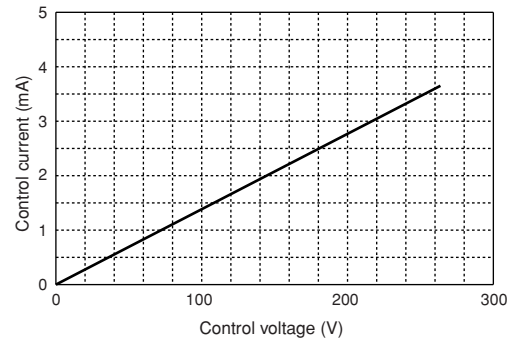

■ Dimensions, mm

SS101C-3Z-D3, -A2  
 SS201C-3Z-D3, -A2  
 SS301C-3Z-D3, -A2

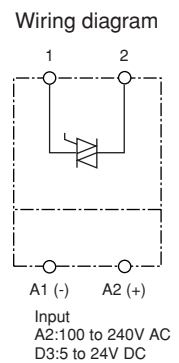
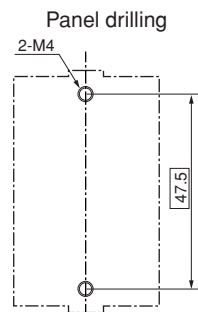
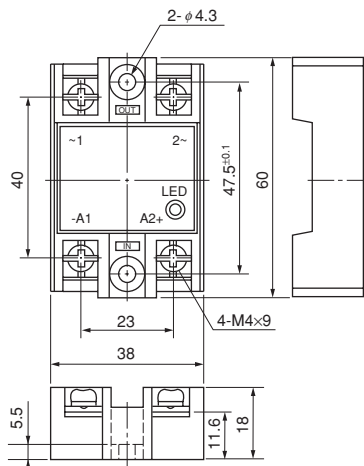

# Solid-state Contactors

## SS series

### Heater load use

#### ■ Cooling fin (Optional)

Type	Ordering code	Mounting	Application SSC
SX1-H9B/X	SY1H9BX	Rail-mounting, screw-mounting	SS101C, SS201C, SS301 C
SX1-I9B/X	SY1I9BX	Rail-mounting, screw-mounting	SS201C, SS301C
SX1-100S	SY1100S	screw-mounting	SS201C, SS301C
SX1-200S	SY1200S	screw-mounting	SS201C, SS301C

#### Dimensions, mm

##### SX1-H9B/X (SS101C, 201C, 301C)

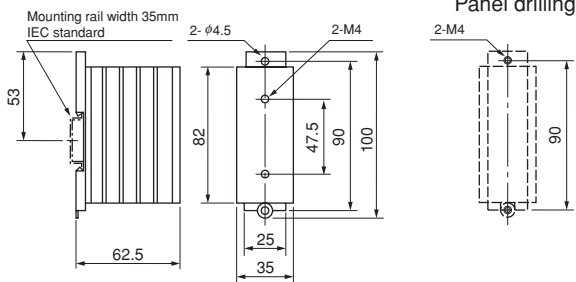

Mass: Approx. 150g

##### SX1-I9B/X (SS201C, SS301C)

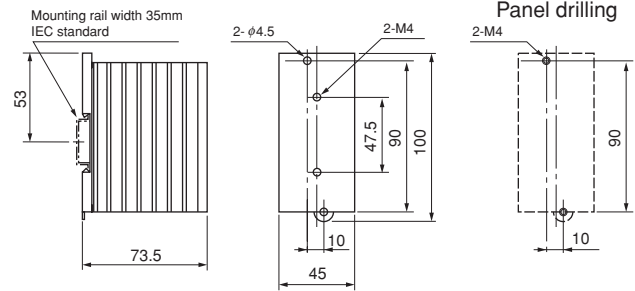

Mass: Approx. 200g

##### SX1-100S (SS201C, SS301C)

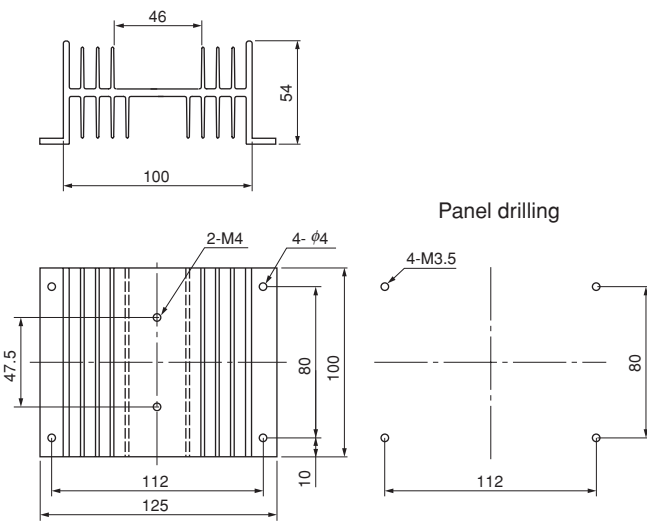

Mass: Approx. 350g

##### SX1-200S (SS201C, 301C)

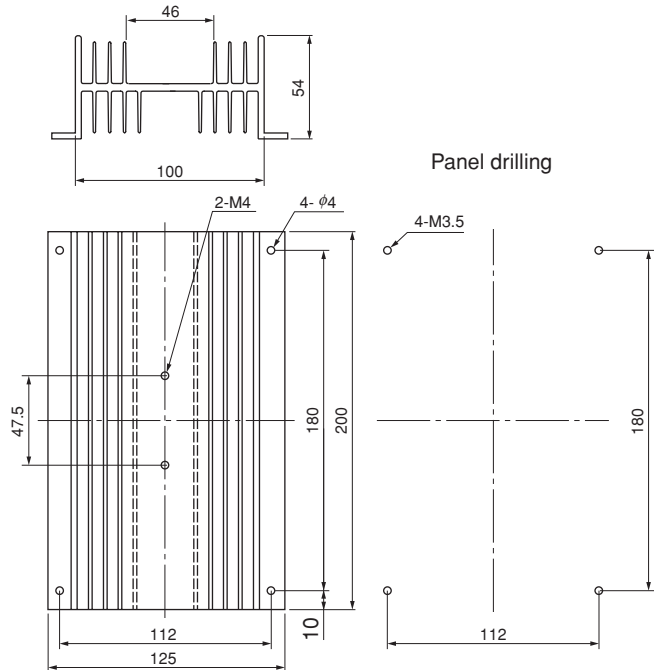

Mass: Approx. 700g

#### ■ Terminal cover (Optional) SX2-C11

##### Dimensions, mm

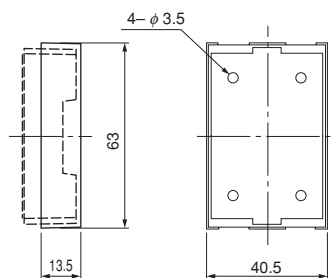

Mass: Approx. 6g

#### ■ Precautions for use

Be sure to read an Instruction Manual enclosed with the solid state relays before using in order to ensure proper operation.

**UL and CSA approved**  
Up to 300HP 240V AC, 3-phase

**Description**

FUJI high quality contactors and starters conform to UL and CSA requirements as they are.

These have high standards of efficiency and safety and are being used throughout the world. We can recommend them with confidence. Other advantages are that they take up less installation space, are easily installed and can replace other starters without trouble because of their compact size.

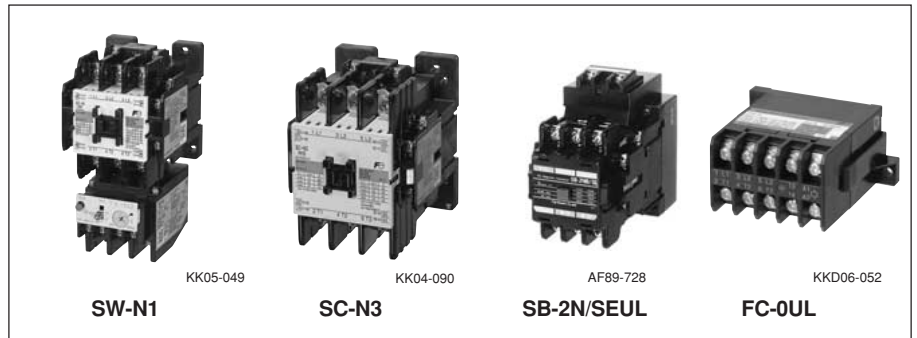

**Ordering information**

Specify the following:

1. Ordering code
2. Overload relay setting range code
3. Operating coil voltage code

UL [File No. E42419, E44592], CSA [File No. LR20479]

**Non reversing contactors (Open type)**

Frame size	Max. motor capacity (HP)				Rated continuous current	Aux. contact NO NC	AC operated			DC operated		
	200V 240V	220V 480V	440V 550V	550V 600V			Type	Ordering code	UL/CSA	Type	Ordering code	UL/CSA
03	2	2	5	5	11A	1 - <sup>1</sup>	SC-03	SC11AA-■10	●	SC-03/G	SC11AG-■10	●
0	3	3	5	5	13A	1 - <sup>1</sup>	SC-0	SC13AA-■10	●	SC-0/G	SC13AG-■10	●
05	3	3	5	5	13A	1 1 <sup>2</sup>	SC-05	SC14AA-■11	●	SC-05/G	SC14AG-■11	●
4-0	5	5	7.5	7.5	20A	1 - <sup>1</sup>	SC-4-0	SC18AA-■10	●	SC-4-0/G	SC18AG-■10	●
4-1	5	5	10	10	20A	1 - <sup>1</sup>	SC-4-1	SC19AA-■10	●	SC-4-1/G	SC19AG-■10	●
5-1	5	5	10	10	20A	1 1 <sup>3</sup>	SC-5-1	SC20AA-■11	●	SC-5-1/G	SC20AG-■11	●
N1	7.5	10	25	25	50A	2 2 <sup>4</sup>	SC-N1	SC25BAA-■22	●	SC-N1/G	SC25BAG-■22	●
N2	10	15	30	30	60A	2 2 <sup>4</sup>	SC-N2	SC35BAA-■22	●	SC-N2/G	SC35BAG-■22	●
N2S	15	20	40	40	80A	2 2 <sup>4</sup>	SC-N2S	SC50BAA-■22	●	SC-N2S/G	SC50BAG-■22	●
N3	20	25	50	50	100A	2 2 <sup>4</sup>	SC-N3	SC65BAA-■22	●	SC-N3/G	SC65BAG-■22	●
N4	25	30	60	60	135A	2 2 <sup>4</sup>	SC-N4	SC80BAA-■22	●			
N5	30	30	60	75	150A	2 2 <sup>4</sup>	SC-N5	SC93BAA-■22	●	SC-N5	SC93BAA-■22	●
N6	40	40	75	100	150A	2 2 <sup>4</sup>	SC-N6	SC1CBAA-■22	●	SC-N6	SC1CBAA-■22	●
N7	50	50	100	125	200A	2 2 <sup>4</sup>	SC-N7	SC1FBAA-■22	●	SC-N7	SC1FBAA-■22	●
N8	60	60	150	150	260A	2 2 <sup>4</sup>	SC-N8	SC1JBAA-■22	●	SC-N8	SC1JBAA-■22	●
N10	75	75	150	200	260A	2 2 <sup>4</sup>	SC-N10	SC2CBAA-■22	●	SC-N10	SC2CBAA-■22	●
N11	100	100	200	250	350A	2 2 <sup>4</sup>	SC-N11	SC3ABAA-■22	●	SC-N11	SC3ABAA-■22	●
N12	125	150	300	350	450A	2 2 <sup>4</sup>	SC-N12	SC4ABAA-■22	●	SC-N12	SC4ABAA-■22	●
N14	200	200	500	600	660A	2 2 <sup>4</sup>	SC-N14	SC6ABAA-■22	●	SC-N14	SC6ABAA-■22	●
N16	250	300	600	700	800A	2 2 <sup>4</sup>	SC-N16	SC8ABAA-■22	●	SC-N16	SC8ABAA-■22	●
N1	7.5	10	25	25	50A	2 2 <sup>4</sup>	SC-N1/SE	SC25BAS-■22	●	SC-N1/SE	SC25BAS-■22	●
N2	10	15	30	30	60A	2 2 <sup>4</sup>	SC-N2/SE	SC35BAS-■22	●	SC-N2/SE	SC35BAS-■22	●
N2S	15	20	40	40	80A	2 2 <sup>4</sup>	SC-N2S/SE	SC50BAS-■22	●	SC-N2S/SE	SC50BAS-■22	●
N3	20	25	50	50	100A	2 2 <sup>4</sup>	SC-N3/SE	SC65BAS-■22	●	SC-N3/SE	SC65BAS-■22	●
N4	25	30	60	60	135A	2 2 <sup>4</sup>	SC-N4/SE	SC80BAS-■22	●	SC-N4/SE	SC80BAS-■22	●

Notes: ● Available  
■ Coil voltage code

<sup>1</sup> Auxiliary contact 1NC is available on request.  
<sup>2</sup> Auxiliary contact 2NO or 2NC is available on request.  
<sup>3</sup> Auxiliary contact 2NO or 2NC or 2NO+2NC is available on request.  
<sup>4</sup> Auxiliary contact 4NO+4NC is available on request for frame sizes N1 and above.

# Magnetic Contactors and Starters

## UL and CSA approved

### Non reversing starters (Open type)

Frame size	Max. motor capacity (HP)				Aux. contact NO NC	AC operated			DC operated		
	200V	220V 240V	440V 480V	550V 600V		Type	Ordering code	UL/CSA	Type	Ordering code	UL/CSA
03	2	2	5	5	1 - *	SW-03/3H	SC11AAN-110T□□	●	SW-03/G3H	SC11AGN-110T□□	●
0	3	3	5	5	1 - *	SW-0/3H	SC13AAN-110T□□	●	SW-0/G3H	SC13AGN-110T□□	●
05	3	3	5	5	1 1 **	SW-05/3H	SC14AAN-111T□□	●	SW-05/G3H	SC14AGN-111T□□	●
4-0	5	5	7.5	7.5	1 - *	SW-4-0/3H	SC18AAN-110T□□	●	SW-4-0/G3H	SC18AGN-110T□□	●
4-1	5	5	10	10	1 - *	SW-4-1/3H	SC19AAN-110T□□	●	SW-4-1/G3H	SC19AGN-110T□□	●
5-1	5	5	10	10	1 1 **	SW-5-1/3H	SC20AAN-111T□□	●	SW-5-1/G3H	SC20AGN-110T□□	●
N1	7.5	10	25	25	2 2 ***	SW-N1/3H	SC25BAAN-222T□□	●	SW-N1/G3H	SC25BGN-110T□□	●
N2	10	15	30	30	2 2 ***	SW-N2/3H	SC35BAAN-222T□□	●	SW-N2/G3H	SC35BGN-110T□□	●
N2S	15	20	40	40	2 2 ***	SW-N2S/3H	SC50BAAN-222T□□	●	SW-N2S/G3H	SC50BGN-110T□□	●
N3	20	25	50	50	2 2 ***	SW-N3/3H	SC65BAAN-222T□□	●	SW-N3/G3H	SC65BGN-110T□□	●
N4	25	30	60	60	2 2 ***	SW-N4/3H	SC80BAAN-222T□□	●	SW-N4/SE3H	SC80BASN-222T□□	●
N5	30	30	60	75	2 2 ***	SW-N5/3H	SC93BAAN-222T□□	●	SW-N5/3H	SC93BAAN-222T□□	●
N6	40	40	75	100	2 2 ***	SW-N6/3H	SC1CBAAN-222T□□	●	SW-N6/3H	SC1CBAAN-222T□□	●
N7	50	50	100	125	2 2 ***	SW-N7/3H	SC1FBAAN-222T□□	●	SW-N7/3H	SC1FBAAN-222T□□	●
N8	60	60	150	150	2 2 ***	SW-N8/3H	SC1JBAAN-222T□□	●	SW-N8/3H	SC1JBAAN-222T□□	●
N10	75	75	150	200	2 2 ***	SW-N10/3H	SC2CBAAN-222T□□	●	SW-N10/3H	SC2CBAAN-222T□□	●
N11	100	100	200	250	2 2 ***	SW-N11/3H	SC3ABAAN-222T□□	●	SW-N11/3H	SC3ABAAN-222T□□	●
N12	125	150	300	350	2 2 ***	SW-N12/3H	SC4ABAAN-222T□□	●	SW-N12/3H	SC4ABAAN-222T□□	●
N14	200	200	500	600	2 2 ***	SW-N14/3H	SC6ABAAN-222T□□	●	SW-N14/3H	SC6ABAAN-222T□□	●
N1	7.5	10	25	25	2 2 ***	SW-N1/SE3H	SC25BASN-222T□□	●	SW-N1/SE3H	SC25BASN-222T□□	●
N2	10	15	30	30	2 2 ***	SW-N2/SE3H	SC35BASN-222T□□	●	SW-N2/SE3H	SC35BASN-222T□□	●
N2S	15	20	40	40	2 2 ***	SW-N2S/SE3H	SC50BASN-222T□□	●	SW-N2S/SE3H	SC50BASN-222T□□	●
N3	20	25	50	50	2 2 ***	SW-N3/SE3H	SC65BASN-222T□□	●	SW-N3/SE3H	SC65BASN-222T□□	●

Notes: ● Available

■ Coil voltage code

□ Thermal overload relay ampere setting range code

\*1 Auxiliary contact 1NC is available on request.

\*\*2 Auxiliary contact 2NO or 2NC is available on request.

\*\*3 Auxiliary contact 2NO or 2NC or 2NO+2NC is available on request.

\*\*4 Auxiliary contact 4NO+4NC is available on request for frame sizes N1 and above.

### Non reversing starters with phase-loss protective device (Open type)

Frame size	Max. motor capacity (HP)				Rated continuous current	Aux. contact NO NC	AC operated			DC operated		
	200V	220V 240V	440V 480V	550V 600V			Type	Ordering code	UL/CSA	Type	Ordering code	UL/CSA
03	2	2	5	5	11A	1 - *	SW-03/2E	SC11AAE-110T□□	●	SW-03/G2E	SC11AGN-110T□□	●
0	3	3	5	5	13A	1 - *	SW-0/2E	SC13AAE-110T□□	●	SW-0/G2E	SC13AGN-110T□□	●
05	3	3	5	5	13A	1 1 **	SW-05/2E	SC14AAE-111T□□	●	SW-05/G2E	SC14AGN-111T□□	●
4-0	5	5	7.5	7.5	20A	1 - *	SW-4-0/2E	SC18AAE-110T□□	●	SW-4-0/G2E	SC18AGN-110T□□	●
4-1	5	5	10	10	20A	1 - *	SW-4-1/2E	SC19AAE-110T□□	●	SW-4-1/G2E	SC19AGN-110T□□	●
5-1	5	5	10	10	20A	1 1 **	SW-5-1/2E	SC20AAE-111T□□	●	SW-5-1/G2E	SC20AGN-110T□□	●
N1	7.5	10	25	25	50A	2 2 ***	SW-N1/2E	SC25BAAE-222T□□	●	SW-N1/G2E	-	●
N2	10	15	30	30	60A	2 2 ***	SW-N2/2E	SC35BAAE-222T□□	●	SW-N2/G2E	-	●
N2S	15	20	40	40	80A	2 2 ***	SW-N2S/2E	SC50BAAE-222T□□	●	SW-N2S/G2E	-	●
N3	20	25	50	50	100A	2 2 ***	SW-N3/2E	SC65BAAE-222T□□	●	SW-N3/G2E	-	●
N4	25	30	60	60	135A	2 2 ***	SW-N4/2E	SC80BAAE-222T□□	●	SW-N4/SE2E	-	●
N5	30	30	60	75	150A	2 2 ***	SW-N5/2E	SC93BAAE-222T□□	●	SW-N5/2E	SC93BAAE-222T□□	●
N6	40	40	75	100	150A	2 2 ***	SW-N6/2E	SC1CBAAE-222T□□	●	SW-N6/2E	SC1CBAAE-222T□□	●
N7	50	50	100	125	200A	2 2 ***	SW-N7/2E	SC1FBAAE-222T□□	●	SW-N7/2E	SC1FBAAE-222T□□	●
N8	60	60	150	150	260A	2 2 ***	SW-N8/2E	SC1JBAAE-222T□□	●	SW-N8/2E	SC1JBAAE-222T□□	●
N10	75	75	150	200	260A	2 2 ***	SW-N10/2E	SC2CBAAE-222T□□	●	SW-N10/2E	SC2CBAAE-222T□□	●
N11	100	100	200	250	350A	2 2 ***	SW-N11/2E	SC3ABAEE-222T□□	●	SW-N11/2E	SC3ABAEE-222T□□	●
N12	125	150	300	350	450A	2 2 ***	SW-N12/2E	SC4ABAEE-222T□□	●	SW-N12/2E	SC4ABAEE-222T□□	●
N14	200	200	500	600	660A	2 2 ***	SW-N14/2E	SC6ABAEE-222T□□	●	SW-N14/2E	SC6ABAEE-222T□□	●
N1	7.5	10	25	25	50A	2 2 ***	SW-N1/2E	SC25BAAE-222T□□	●	SW-N1/SE2E	-	●
N2	10	15	30	30	60A	2 2 ***	SW-N2/2E	SC35BAAE-222T□□	●	SW-N2/SE2E	-	●
N2S	15	20	40	40	80A	2 2 ***	SW-N2S/2E	SC50BAAE-222T□□	●	SW-N2S/SE2E	-	●
N3	20	25	50	50	100A	2 2 ***	SW-N3/2E	SC65BAAE-222T□□	●	SW-N3/SE2E	-	●
N4	25	30	60	60	135A	2 2 ***	SW-N4/2E	SC80BAAE-222T□□	●	SW-N4/SE2E	-	●

Notes: ● Available

■ Coil voltage code

□ Thermal overload relay ampere setting range code

\*1 Auxiliary contact 1NC is available on request.

\*\*2 Auxiliary contact 2NO or 2NC is available on request.

\*\*3 Auxiliary contact 2NO or 2NC or 2NO+2NC is available on request.

\*\*4 Auxiliary contact 4NO+4NC is available on request for frame sizes N1 and above.

Reversing contactors and starters (Open type)

Auxiliary contact NO NC	Contactor AC operated		Starter Standard Type	Ordering code	With phase-loss protective device Type	Ordering code	Approved 
	Type	Ordering code					
- 2 *1	SC-03RM	SC11RA-■01	SW-03RM/3H	SC11RAN-■01T □D	SW-03RM/2E	SC11RAE-■01T□	●
- 2 *1	SC-0RM	SC13RA-■01	SW-0RM/3H	SC13RAN-■01T □D	SW-0RM/2E	SC13RAE-■01T□	●
2 2 *2	SC-05RM	SC14RA-■11	SW-05RM/3H	SC14RAN-■11T □D	SW-05RM/2E	SC14RAE-■11T□	●
- 2 *1	SC-4-0RM	SC18RA-■01	SW-4-0RM/3H	SC18RAN-■01T □D	SW-4-0RM/2E	SC18RAE-■01T□	●
- 2 *1	SC-4-1RM	SC19RA-■01	SW-4-1RM/3H	SC19RAN-■01T □D	SW-4-1RM/2E	SC19RAE-■01T□	●
2 2 *3	SC-5-1RM	SC20RA-■11	SW-5-1RM/3H	SC20RAN-■11T □D	SW-5-1RM/2E	SC20RAE-■11T□	●
4 4 *4	SC-N1RM	SC25BRA-■22	SW-N1RM/3H	SC25BRAN-■22T □D	SW-N1RM/2E	SC25BRAE-■22T□	●
4 4 *4	SC-N2RM	SC35BRA-■22	SW-N2RM/3H	SC35BRAN-■22T □D	SW-N2RM/2E	SC35BRAE-■22T□	●
4 4 *4	SC-N2SRM	SC50BRA-■22	SW-N2SRM/3H	SC50BRAN-■22T □D	SW-N2SRM/2E	SC50BRAE-■22T□	●
4 4 *4	SC-N3RM	SC65BRA-■22	SW-N3RM/3H	SC65BRAN-■22T □D	SW-N3RM/2E	SC65BRAE-■22T□	●
4 4 *4	SC-N4RM	SC80BRA-■22	SW-N4RM/3H	SC80BRAN-■22T □	SW-N4RM/2E	SC80BRAE-■22T□	●
4 4 *4	SC-N5RM	SC93BRA-■22	SW-N5RM/3H	SC93BRAN-■22T □	SW-N5RM/2E	SC93BRAE-■22T□	●
4 4 *4	SC-N6RM	SC1CBRA-■22	SW-N6RM/3H	SC1CBRAN-■22T □	SW-N6RM/2E	SC1CBRAE-■22T□	●
4 4 *4	SC-N7RM	SC1FBRA-■22	SW-N7RM/3H	SC1FBRAN-■22T □	SW-N7RM/2E	SC1FBRAE-■22T□	●
4 4 *4	SC-N8RM	SC1JBRA-■22	SW-N8RM/3H	SC1JBRAN-■22T □	SW-N8RM/2E	SC1JBRAE-■22T□	●
4 4 *4	SC-N10RM	SC2CBRA-■22	SW-N10RM/3H	SC2CBRAN-■22T □	SW-N10RM/2E	SC2CBRAE-■22T□	●
4 4 *4	SC-N11RM	SC3ABRA-■22	SW-N11RM/3H	SC3ABRAN-■22T □	SW-N11RM/2E	SC3ABRAE-■22T□	●
4 4 *4	SC-N12RM	SC4ABRA-■22	SW-N12RM/3H	SC4ABRAN-■22T □	SW-N12RM/2E	SC4ABRAE-■22T□	●
4 4 *4	SC-N14RM	SC6ABRA-■22	SW-N14RM/3H	SC6ABRAN-■22T □	SW-N14RM/2E	SC6ABRAE-■22T□	●

Notes: ● Available

■ Coil voltage code

□ Thermal overload relay ampere setting range code

Ratings are same as non-reversing types.

\*1 Auxiliary contact 2NO is available on request.

\*2 Auxiliary contact 4NC is available on request.

\*3 Auxiliary contact 4NC, 4NO+4NC is available on request.

\*4 Auxiliary contact 6NO+6NC is available on request.

● Coil characteristics

Frame size 03 to N4

Coil operating voltage				Code
24V	50Hz /	24-26V	60Hz	<b>E</b>
48V	50Hz /	48-52V	60Hz	<b>F</b>
100V	50Hz /	100-110V	60Hz	<b>1</b>
100-110V	50Hz /	110-120V	60Hz	<b>H</b>
110-120V	50Hz /	120-130V	60Hz	<b>K</b>
200V	50Hz /	200-220V	60Hz	<b>2</b>
200-220V	50Hz /	220-240V	60Hz	<b>M</b>
220-240V	50Hz /	240-260V	60Hz	<b>P</b>
346-380V	50Hz /	380-420V	60Hz	<b>S</b>
380-400V	50Hz /	400-440V	60Hz	<b>4</b>
415-440V	50Hz /	440-480V	60Hz	<b>T</b>
480-500V	50Hz /	500-550V	60Hz	<b>5</b>

Note: Other voltages are available in 24-600V AC range on request.

Frame size N5 to N16

Coil operating voltage			Code
AC	DC		
24-25V	50/60Hz	24V	<b>E</b>
48-50V	50/60Hz	48V	<b>F</b>
100-127V	50/60Hz	100-120V	<b>1</b>
200-250V	50/60Hz	200-240V	<b>2</b>
380-450V	50/60Hz	—	<b>4</b>

Notes: • Be careful of these voltages because they are different from the standard range.  
• 24V and 48V is not available for N14 and 16.

Frame size 03/G to N3/G

Coil operating voltage		Code
DC		
12V		<b>B</b>
24V		<b>E</b>
48V		<b>F</b>
60V		<b>G</b>
100V		<b>1</b>
110V		<b>H</b>
120V		<b>K</b>
200V		<b>2</b>
210V		<b>Y</b>
220V		<b>M</b>

Note: Other voltages are available in 12-250V DC range on request.

# Magnetic Contactors and Starters

## UL and CSA approved

### Thermal overload relays

Standard type Type	Ordering code	With phase-loss protective device Type	Ordering code	Setting range (A)	Reset	Combined motor starter	
						Standard	With phase-loss protective device
TR-0N/3	TR13DW-□	TK-0N	TR13EW-□	0.1-0.15, 0.13-0.2, 0.15-0.24, 0.2-0.3 0.24-0.36, 0.3-0.45, 0.36-0.54, 0.48-0.72 0.64-0.96, 0.8-1.2, 0.95-1.45, 1.4-2.2 1.7-2.6, 2.2-3.4, 2.8-4.2, 4-6, 5-8, 6-9 7-11	Manual/auto	SW-03/3H SW-0/3H SW-05/3H	SW-03/2E SW-0/2E SW-05/2E
TR-5-1N/3	TR20DW-□	TK-5-1N	TR20EW-□	0.1-0.15, 0.13-0.2, 0.15-0.24, 0.2-0.3 0.24-0.36, 0.3-0.45, 0.36-0.54 0.48-0.72, 0.64-0.96, 0.8-1.2, 0.95-1.45 1.4-2.2, 1.7-2.6, 2.2-3.4, 2.8-4.2, 4-6 5-8, 6-9, 7-11, 9-13, 12-18	Manual/auto	SW-4-0/3H SW-4-1/3H SW-5-1/3H	SW-4-0/2E SW-4-1/2E SW-5-1/2E
TR-N2/3 TR-N2H/3*	TR35BDW-□ TR35BDH-□	TK-N2 TK-N2H*	TR35BEW-□ TR35BEH-□	4-6, 5-8, 6-9, 7-11, 9-13, 12-18 18-26, 24-36, 32-42	Manual/auto	SW-N1/3H SW-N2/3H	SW-N1/2E SW-N2/2E
TR-N3/3 TR-N3H/3*	TR65BDW-□ TR65BDH-□	TK-N3 TK-N3H*	TR65BEW-□ TR65BEH-□	7-11, 9-13, 12-18, 18-26, 24-36 28-40, 34-50, 45-65, 48-68	Manual/auto	SW-N2S/3H SW-N3/3H	SW-N2S/2E SW-N3/2E
TR-N5/3	TR93BDW-□	TK-N5	TR93BEW-□	7-11, 9-13, 12-18, 18-26, 24-36, 28-40 34-50, 45-65, 53-80, 65-95	Manual/auto	SW-N4/3H SW-N5/3H	SW-N4/2E SW-N5/2E
TR-N6/3 TR-N6H/3*	TR1CBDW-□ TR1CBDH-□	TK-N6 TK-N6H*	TR1CBEW-□ TR1CBEH-□	45-65, 53-80, 65-95, 85-125	Manual/auto	SW-N6/3H	SW-N6/2E
TR-N7/3	TR1FBDW-□	TK-N7	TR1FBEW-□	45-65, 53-80, 65-95, 85-125, 110-160	Manual/auto	SW-N7/3H	SW-N7/2E
TR-N8/3	TR1JBDW-□	TK-N8	TR1JBEW-□	53-80, 65-95, 85-125, 110-160, 125-185	Manual/auto	SW-N8/3H	SW-N8/2E
TR-N10/3 TR-N10H/3*	TR2CBDW-□ TR2CBDH-□	TK-10N TK-10NH*	TR2CBEW-□ TR2CBEH-□	85-125, 110-160, 125-185, 160-240	Manual/auto	SW-N10/3H	SW-N10/2E
TR-N12/3 TR-N12H/3*	TR4ABDW-□ TR4ABDH-□	TK-12N TK-12NH*	TR4ABEW-□ TR4ABEH-□	110-160, 125-185, 160-240, 200-300, 240-360, 300-450	Manual/auto	SW-N11/3H SW-N12/3H	SW-N11/2E SW-N12/2E
TR-N14/3 TR-N14H/3*	TR6ABDW-□ TR6ABDH-□	TK-14N TK-14NH*	TR6ABEW-□ TR6ABEH-□	240-360, 300-450, 400-600	Manual/auto	SW-N14/3H	SW-N14/2E

Notes: □ Enter the thermal overload relay ampere setting range code

- \*Separate mounting type
- Auxiliary contact: 1NO+1NC
- UL recognized

• Max. setting ranges of these starters are as follows.

Starter	Max. setting range	Starter	Max. setting range
SW-03	5-8A	SW-N1	24-36A
SW-N2S	45-65A	SW-N4	53-80A

### ● Auxiliary contact ratings

#### Contactors

Frame size	Continuous current (A)	AC	Make/Break (A)	DC	Make/Break (A)
SC-03 to N14	10	120V 240V 480V 600V	60/6 30/3 15/1.5 12/1.2	125V 250V	0.55/0.55 0.27/0.27

### Thermal overload relays

Frame	Continuous current (A)	AC	Make/Break (A)	DC	Make/Break (A)
TR-0N/3 to 5-1N/3 TK-0N to 5-1N	2.5	120V 240V 480V 600V	15/1.5 7.5/0.75 3.75/0.375 3/0.3	125V 250V	0.22A/0.22 0.11A/0.11
TR-N2/3 to N14/3 TK-N2 to N14	5	120V 240V 480V 600V	30/3 15/1.5 7.5/0.75 6/0.6	125V 250V	0.22A/0.22 0.11A/0.11

### ● Thermal overload relays

#### Ampere setting ranges and codes

Ampere setting range (A)	Code	Ampere setting range (A)	Code	Ampere setting range (A)	Code
0.1 - 0.15	A	4 - 6	S	65 - 95	M
0.13 - 0.2	B	5 - 8	T	85 - 105	I
0.15 - 0.24	C	6 - 9	U	85 - 125	N
0.2 - 0.3	D	7 - 11	V	110 - 160	P
0.24 - 0.36	E	9 - 13	W	125 - 185	R
0.3 - 0.45	F	12 - 18	X	160 - 240	S
0.36 - 0.54	G	16 - 22	Q	200 - 300	T
0.48 - 0.72	H	18 - 26	B	240 - 360	U
0.64 - 0.96	J	24 - 36	E	300 - 450	V
0.8 - 1.2	K	28 - 40	F	400 - 600	W
0.95 - 1.45	L	32 - 42	I		
1.4 - 2.2	M	34 - 50	G		
1.7 - 2.6	N	45 - 65	J		
2.2 - 3.4	P	48 - 68	O		
2.8 - 4.2	R	53 - 80	L		

### ● Dimensions

See page 01/34 for standard contactor and starter.

See page 01/43 for reversing contactor and starter.

See page 01/50 for DC operated contactor.

See page 01/103 for thermal overload relay.



**DC contactor SB series UL [File No. E42419], CSA [File No. LR20479]**

Type	Ordering code	Main contact arrangement	Current ratings (A)						DC motor control (DC2, class4)				Continuous current (A)	
			Variable-speed motor control										NO	NC
			2NO (in series)*1		1NC (dynamic brake)*2		2NO (in series)							
110V/240V	440V/500V	110V/240V	440V/500V	110V	240V	440V	500V	110V	240V	440V	500V			
<b>SB-2N/UL</b>	SB351AA- <input type="checkbox"/>	2NO	50	35	75	75	40	35	18	15	50	50		
<b>SB-2NB/UL</b>	SB351AB-21 <input type="checkbox"/>	2NO+1NC												
<b>SB-2N/SEUL</b>	SB351SA- <input type="checkbox"/>	2NO	50	35	75	75	40	35	18	15	50	50		
<b>SB-2NB/SEUL</b>	SB351SB-21 <input type="checkbox"/>	2NO+1NC												
<b>SB-5N/UL</b>	SB851BA- <input type="checkbox"/>	2NO	110	110	165	165	85	85	60	45	110	100		
<b>SB-5NB/UL</b>	SB851BB- <input type="checkbox"/>	2NO+1NC												
<b>SB-6N/UL</b>	SB1C1BA- <input type="checkbox"/>	2NO	140	140	210	210	125	120	80	50	140	100		
<b>SB-6NB/UL</b>	SB1C1BB- <input type="checkbox"/>	2NO+1NC												
<b>SB-10N/UL</b>	SB2A1BA- <input type="checkbox"/>	2NO	240	240	360	360	240	200	120	100	240	160		
<b>SB-10NB/UL</b>	SB2A1BB- <input type="checkbox"/>	2NO+1NC												
<b>SB-11N/UL</b>	SB2K1BA- <input type="checkbox"/>	2NO	320	320	480	480	320	290	200	150	320	200		
<b>SB-11NB/UL</b>	SB2K1BB- <input type="checkbox"/>	2NO+1NC												

Notes: • Enter the coil voltage code in the  mark. • On-load factor is 50%, operating cycle is 600 cycles per hour.  
 • Enter the auxiliary contact arrangement in the  mark. • Breaking condition : No voltage  
 • 22: 2NO+2NC (standard), 33: 3NO+3NC (on request),  
 • 44: 4NO+4NC (on request)  
 \*1 NO contacts are capable of making 2 times of listed current ratings.  
 \*2 NC contacts are capable of making 1 time of listed current ratings.

**● Auxiliary contact ratings**

Rating code	Continuous current (A)	Current ratings (A) Voltage	Make Break	
			Make	Break
A600	10	120V AC	60	6
		240V AC	30	3
		480V AC	15	1.5
		600V AC	12	1.2
Q300	10	125V DC	0.55	0.55
		250V DC	0.27	0.27

**Optional units UL [File No. E44592], CSA [File No. LR20479]**

Description		Type	Ordering code	Used with		
Auxiliary contact block	Front mounting	<b>SZ-A40</b>	SZ1A40 4NO	SC-03 to 5-1 SH-4,5 SC-N1 to N3		
		<b>SZ-A31</b>	SZ1A31 3NO+1NC			
		<b>SZ-A22</b>	SZ1A22 2NO+2NC			
		<b>SZ-A20</b>	SZ1A20 2NO			
		<b>SZ-A11</b>	SZ1A11 1NO+1NC			
		<b>SZ-A02</b>	SZ1A02 2NC			
	Side mounting	<b>SZ-AS1</b>	SZ1AS1 1NO+1NC	SC-03 to N3 SC-N4 to N12		
		<b>SZ-AS2</b>	SZ1AS2 1NO+1NC			
Mechanical interlock unit		<b>SZ-RM</b>	SZ1RM	SC-03 to 5-1 SC-N1 to N3		
Coil surge suppression unit	Varistor	<b>SZ-Z1</b>	SZ1Z1 24 to 48V AC/DC	SC-03 to 5-1 SH-4, 5		
		<b>SZ-Z2</b>	SZ1Z2 100 to 250V AC/DC			
		<b>SZ-Z3</b>	SZ1Z3 380 to 440V AC/DC			
		<b>SZ-Z6*2</b>	SZ1Z6 24 to 48V AC/DC			
		<b>SZ-Z7*2</b>	SZ1Z7 100 to 250V AC/DC			
		<b>SZ-Z31</b>	SZ2Z31 24 to 48V AC/DC		SC-N1 to N3 SC-N1/G to N3/G	
		<b>SZ-Z32</b>	SZ2Z32 100 to 250V AC/DC			
	<b>SZ-Z33</b>	SZ2Z33 380 to 440V AC/DC				
	CR		<b>SZ-Z41</b>	SZ2Z41 24 to 48V AC	SC-N4	
			<b>SZ-Z42</b>	SZ2Z42 100 to 250V AC		
			<b>SZ-Z43</b>	SZ2Z43 380 to 440V AC		
				<b>SZ-Z4</b>	SZ1Z4 24 to 48V AC/DC	SC-03 to 5-1 SH-4, 5
				<b>SZ-Z5</b>	SZ1Z5 100 to 250V AC/DC	
				<b>SZ-Z8*2</b>	SZ1Z8 24 to 48V AC/DC	
<b>SZ-Z9*2</b>				SZ1Z9 100 to 250V AC/DC		
		<b>SZ-Z34</b>	SZ2Z34 24 to 48V AC	SC-N1 to N3		
		<b>SZ-Z35</b>	SZ2Z35 100 to 250V AC			
		<b>SZ-Z36</b>	SZ2Z36 24 to 48V DC		SC-N1/G to N3/G	
		<b>SZ-Z37</b>	SZ2Z37 100 to 250V DC			
		<b>SZ-Z44</b>	SZ2Z44 24 to 48V AC	SC-N4		
		<b>SZ-Z45</b>	SZ2Z45 100 to 250V AC			

Notes: \*1 Overlapping  
 \*2 With LED

**● Dimensions**

Same as standard type  
 See page 01/90.

Description		Type	Ordering code	Used with
Main circuit surge suppression unit	<b>SZ-ZM1</b>	SZ1ZM1	SC-03 to 5-1	
	<b>SZ-ZM2</b>	SZ1ZM2	SC-03 to 5-1	
	<b>SZ-ZM3</b>	SZ1ZM3	SC-N1 to N3	
	<b>SZ-ZM4</b>	SZ1ZM4	SC-N1 to N3	
Terminal cover	For contactor and industrial relay	<b>SZ-T1</b>	SZ1T1	SC-03, 0, SH-4
		<b>SZ-T2</b>	SZ1T2	SC-05, SH-5
		<b>SZ-T3</b>	SZ1T3	SC-4-0, 4-1
		<b>SZ-T4</b>	SZ1T4	SC-5-1
		<b>SZ-T22</b>	SZ2T22	SC-N1, N2
		<b>SZ-T23</b>	SZ2T23	SC-N2S, N3
		<b>SZ-N4T</b>	SZ2N4T	SC-N4, N5, SW-N4/3H, N5/3H
		<b>SZ-N6T</b>	SZ2N6T	SC-N6, SW-N6/3H
		<b>SZ-N7T</b>	SZ2N7T	SC-N7, SW-N7/3H
		<b>SZ-N8T</b>	SZ2N8T	SC-N8, N10, SW-N8/3H, N10/3H
		<b>SZ-N11T</b>	SZ2N11T	SC-N11, N12, SW-N11/3H, N12/3H
For auxiliary contact block	<b>SZ-WN4T</b>	SZ2WN7T	SW-N4/3H, N5/3H	
	<b>SZ-WN6T</b>	SZ2WN7T	SW-N6/3H	
	<b>SZ-WN7T</b>	SZ2WN7T	SW-N7/3H	
	<b>SZ-WN8T</b>	SZ2WN7T	SW-N8/3H	
	<b>SZ-WN10T</b>	SZ2WN7T	SW-N10/3H	
	<b>SZ-WN11T</b>	SZ2WN7T	SW-N11/3H, N12/3H	
	<b>SZ-T5</b>	SZ1T5	SZ-A40, SZ-A31, SZ-A22	
	<b>SZ-T6</b>	SZ1T6	SZ-A20, SZ-A11, SZ-A02	
	<b>SZ-T7</b>	SZ1T7	SZ-AS1, SZ-AS2	
	For thermal overload relay	<b>SZ-T10</b>	SZ1T10	SZ-HB
<b>SZ-T11</b>		SZ1T11	SZ-HC	
<b>SZ-T12</b>		TZ1T12	TR-0N/3, TK-0N	
<b>SZ-T13</b>		TZ1T13	TR-5-1N/3, TK-5-1N	
<b>SZ-T14</b>		SZ2T14	TR-N2H/3, TK-N2H	
<b>SZ-T15</b>		SZ2T15	TR-N3H/3, TK-N3H	
<b>SZ-RN6T</b>		SZ2RN6T	TR-N6H/3, TK-N6H	
<b>SZ-T16</b>		SZ2T16	TR-N2/3, TK-N2	
<b>SZ-T17</b>		SZ2T17	TR-N3/3, TK-N3	
Base unit for separate mounting		<b>SZ-HB</b>	TZ1HB	TR-0N/3, TK-0N
	<b>SZ-HC</b>	TZ1HC	TR-5-1N/3, TK-5-1N	
	<b>SZ-HD</b>	TZ2HD	TR-N2/3, TK-N2	
	<b>SZ-HE</b>	TZ2HE	TR-N3/3, TK-N3	
Reset release button	<b>SZ-R1</b>	TZ1R1	TR-0N/3, TK-0N, TR-5-1N/3	
	<b>SZ-R2</b>	TZ1R2	TK-5-1N	
	<b>SZ-R3</b>	TZ1R3	TR-N10/3 to N14/3, TK-N10 to N14	
	<b>SZ-R4</b>	TZ2R4	TR-N2/3 to N8/3	
	<b>SZ-R5</b>	TZ2R5	TK-N2 to N8	
	<b>SZ-R6</b>	TZ2R6		
Dial cover	<b>SZ-DA</b>	SZ1DA	TR-0N/3 to N14/3 TK-0N to TK-N14	

# Magnetic Contactors and Starters

## UL and CSA approved

### Definite purpose contactors UL [File No. E42419], CSA [File No. LR20479]

Type	Ordering code		Terminal	Auxiliary contact arrangement	Motor capacity (HP)						Thermal continuous current (A)
					Single-phase		3-phase				
					110V 120V	220V 240V	200V	220V 240V	440V 480V	550V 600V	
FC-0UL FC-0TUL FC-0SUL FC-0STUL	SF12B1A-■10*1 SF12B3A-■10*1 SF15B1A-■10*1 SF15B3A-■10*1	● ● ● ●	Screw Tab Screw Tab	1NO	1/2	1	1	1	–	–	15
FC-1UL FC-1SUL FC-2SUL FC-3UL FC-4UL	SF20B1A-■11*2 SF26B1A-■11*2 SF38B1A-■11*2 SF50B1A-■11*2 SF65B1A-■11*2	● ● ● ● ●	Screw Screw Screw Screw Screw	1NO +1NC	1 2 3 3 5	2 3 5 7.5 10	5 5 10 10 15	5 7.5 10 15 20	7.5 10 15 25 30	7.5 7.5 10 15 25	20 26 35 45 65
FC-0/GUL FC-0T/GUL FC-0S/GUL FC-0ST/GUL	SF12B1G-■10*1 SF12B3G-■10*1 SF15B1G-■10*1 SF15B3G-■10*1	● ● ● ●	Screw Tab Screw Tab	1NO	1/2	1	1	1	–	–	15

Notes: \*1 1NO is standard, 1NC is also available on request. ● Approved ■ Coil voltage code  
\*2 1NO+1NC is standard, 2NO or 2NC is also available on request.

### Auxiliary contact ratings

Type	Rating code	Thermal continuous current (A)	Current ratings (A)								Maximum (VA)	
			120V AC		240V AC		480V AC		600V AC		Make	Break
			Make	Break	Make	Break	Make	Break	Make	Break		
FC-0UL FC-0TUL FC-0SUL FC-0STUL	B300	5	30	3	15	1.5	–	–	–	–	3600	360
FC-1UL FC-1SUL FC-2SUL FC-3UL FC-4UL	A600	10	60	6	30	3	15	1.5	12	1.2	7200	720
FC-0/GUL FC-0T/GUL FC-0S/GUL FC-0ST/GUL	B300	5	30	3	15	1.5	–	–	–	–	3600	360

### Operating coil voltage

FC-0UL, 0TUL, 0SUL, 0STUL, 1UL, FC-1SUL, 2SUL, 3UL, 4UL

Voltage and frequency	Code
24V 50Hz/24 – 26V 60Hz	E
48V 50Hz/48 – 52V 60Hz	F
100V 50Hz/100 – 110V 60Hz	1
100 – 110V 50Hz/110 – 120V 60Hz	H
110 – 120V 50Hz/120 – 130V 60Hz	K
200V 50Hz/200 – 220V 60Hz	2
200 – 220V 50Hz/220 – 240V 60Hz	M

FC-0/GUL, 0T/GUL  
FC-0S/GUL, 0ST/GUL

Voltage	Code
24V DC	E
48V DC	F
100V DC	1
110V DC	H
200V DC	2
220V DC	M

### Wiring diagrams

FC-0UL, 0TUL, 0/GUL, 0T/GUL  
FC-0SUL, 0STUL, 0S/GUL, 0ST/GUL

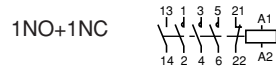
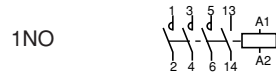

FC-1UL, 1SUL, 2SUL, 3UL, 4UL

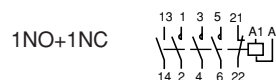

### Dimensions, mm

See page 01/92.

**Solid-state contactors SS series UL** [File No. E132864, E142975]

**Single pole type**

● **Main circuit 240V AC, SS101 to SS2001**

Type	<b>SS101-5Z-A3</b> <b>SS101-5Z-A4</b> <b>SS101-3Z-D3</b>	<b>SS201-5Z-A3</b> <b>SS201-5Z-A4</b> <b>SS201-3Z-D3</b>	<b>SS301-5Z-A3</b> <b>SS301-5Z-A4</b> <b>SS301-3Z-D3</b>	<b>SS401-5Z-A3</b> <b>SS401-5Z-A4</b> <b>SS401-3Z-D3</b>	<b>SS501-5Z-A3</b> <b>SS501-5Z-A4</b> <b>SS501-3Z-D3</b>
Ordering code	SS101-5ZA3 SS101-5ZA4 SS101-3ZD3	SS201-5ZA3 SS201-5ZA4 SS201-3ZD3	SS301-5ZA3 SS301-5ZA4 SS301-3ZD3	SS401-5ZA3 SS401-5ZA4 SS401-3ZD3	SS501-5ZA3 SS501-5ZA4 SS501-3ZD3
Rated thermal current(A) *	10	20	30	40	50
Control voltage	A3 : 100V-120V AC, A4 : 200-240V AC, D3 : 5-24V DC				

Type	<b>SS701-1Z-A3</b> <b>SS701-1Z-A4</b> <b>SS701-3Z-D3</b>	<b>SS1001-1Z-A3</b> <b>SS1001-1Z-A4</b> <b>SS1001-3Z-D3</b>	<b>SS1501-1Z-A3</b> <b>SS1501-1Z-A4</b> <b>SS1501-3Z-D3</b>	<b>SS2001-1Z-A3</b> <b>SS2001-1Z-A4</b> <b>SS2001-3Z-D3</b>	
Ordering code	SS701-1ZA3 SS701-1ZA4 SS701-3ZD3	SS1A1-1ZA3 SS1A1-1ZA4 SS1A1-3ZD3	SS1F1-1ZA3 SS1F1-1ZA4 SS1F1-3ZD3	SS1A1-1ZA3 SS1A1-1ZA4 SS1A1-3ZD3	
Rated thermal current(A) *	70	100	150	200	
Control voltage	A3 : 100V-120V AC, A4 : 200-240V AC, D3 : 5-24V DC				

● **Main circuit 480V AC, SS701H to SS2001H**

Type	<b>SS701H-1Z-A3</b> <b>SS701H-1Z-A4</b> <b>SS701H-3Z-D3</b>	<b>SS1001H-1Z-A3</b> <b>SS1001H-1Z-A4</b> <b>SS1001H-3Z-D3</b>	<b>SS1501H-1Z-A3</b> <b>SS1501H-1Z-A4</b> <b>SS1501H-3Z-D3</b>	<b>SS2001H-1Z-A3</b> <b>SS2001H-1Z-A4</b> <b>SS2001H-3Z-D3</b>	
Ordering code	SS701H-1ZA3 SS701H-1ZA4 SS701H-3ZD3	SS1A1H-1ZA3 SS1A1H-1ZA4 SS1A1H-3ZD3	SS1F1H-1ZA3 SS1F1H-1ZA4 SS1F1H-3ZD3	SS1A1H-1ZA3 SS1A1H-1ZA4 SS1A1H-3ZD3	
Rated thermal current(A) *	70	100	150	200	
Control voltage	A3 : 100V-120V AC, A4 : 200-240V AC, D3 : 5-24V DC				

Note: \* The values are maximum ratings that apply at an ambient temperature not exceeding 40°C.

**3-pole type**

● **Main circuit 240V AC**

Contactor 3-pole, 2-element		3-pole, 3-element		Cooling fin to be combined 3-pole, 2-element				Continuous current (A)	Motor ratings 3-phase 220V AC 60Hz	
Basic type	Basic ordering code	Basic type	Basic ordering code	Basic type	Basic ordering code	Basic type	Basic ordering code		Capacity (HP)	Full load current (A)
<b>SS032</b>	SS032	<b>SS033</b>	SS033	—	—	—	—	3	1/2	2
<b>SS082</b>	SS082	<b>SS083</b>	SS083	*	*	*	*	8	3/4	2.9
<b>SS202</b>	SS202	<b>SS203</b>	SS203	<b>SX1-D10</b>	SY1D0	<b>SX1-D10</b>	SY1D0	20	1 1/2	5.2
<b>SS302</b>	SS302	<b>SS303</b>	SS303	<b>SX1-D10</b>	SY1D0	<b>SX1-E12</b>	SY1E2	30	2	5.8
<b>SS402</b>	SS402	<b>SS403</b>	SS403	<b>SX1-D14</b>	SY1D4	<b>SX1-E12</b>	SY1E2	40	3	9.6
<b>SS502</b>	SS502	<b>SS503</b>	SS503	<b>SX1-E12</b>	SY1E2	<b>SX1-E17</b>	SY1E7	50	5	15.2
<b>SS802</b>	SS802	<b>SS803</b>	SS803	<b>SX1-C12</b>	SY1C2	<b>SX1-C12</b>	SY1C2	80	10	28
<b>SS1202</b>	SS1C2	<b>SS1203</b>	SS1C3	<b>SX1-C12</b>	SY1C2	<b>SX1-C12</b>	SY1C2	120	10	28

Note: \* Cooling fin provided

● **Main circuit 480V AC**

Contactor 3-pole, 2-element		3-pole, 3-element		Cooling fin to be combined 3-pole, 2-element				Continuous current (A)	Motor ratings 3-phase 440V AC 60Hz	
Basic type	Basic ordering code	Basic type	Basic ordering code	Basic type	Basic ordering code	Basic type	Basic ordering code		Capacity (HP)	Full load current (A)
<b>SS302H</b>	SS302H	<b>SS303H</b>	SS303H	<b>SX1-E12</b>	SY1E2	<b>SX1-E12</b>	SY1E2	30	—	—
<b>SS502H</b>	SS502H	<b>SS503H</b>	SS503H	<b>SX1-E12</b>	SY1E2	<b>SX1-E17</b>	SY1E7	50	10	17
<b>SS802H</b>	SS802H	<b>SS803H</b>	SS803H	<b>SX1-C12</b>	SY1C2	<b>SX1-C12</b>	SY1C2	80	20	32.5
<b>SS1202H</b>	SS1C2H	<b>SS1203H</b>	SS1C3H	<b>SX1-C12</b>	SY1C2	<b>SX1-C12</b>	SY1C2	120	20	32.5

● **Input voltage**

- 100–120/200–240V AC
- 100–120V AC
- 200–240V AC
- 12/24V DC
- 12–24V DC
- 5V DC
- 5–24V DC

Note: For details, see page 01/128.

# Magnetic Contactors and Starters

## TÜV approved

### TÜV approved

#### ■ Description

FUJI contactors and starters introduced in this section are TÜV approved products as they are.

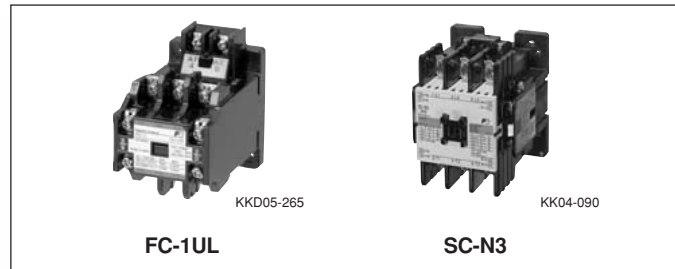

### Contactor SC series

AC operated		DC operated		Max. motor capacity (kW)*5		Rated operational current (A)*5		Continuous current (A)	Auxiliary contact	
Type	Ordering code	Type	Ordering code	200V 240V	380V 440V	200V 240V	380V 440V		NO	NC
SC-03	SC11AA-■10	SC-03/G	SC11AG-■10	2.5	4	11	9	20	1	—*1
SC-0	SC13AA-■10	SC-0/G	SC13AG-■10	3.5	5.5	13	12	20	1	—*1
SC-05	SC14AA-■11	SC-05/G	SC14AG-■11	3.5	5.5	13	12	20	1	1*2
SC-4-0	SC18AA-■10	SC-4-0/G	SC18AG-■10	4.5	7.5	18	16	25	1	—*1
SC-4-1	SC19AA-■10	SC-4-1/G	SC19AG-■10	5.5	11	22	22	32	1	—*1
SC-5-1	SC20AA-■11	SC-5-1/G	SC20AG-■11	5.5	11	22	22	32	1	1*3
SC-N1	SC25BAA-■22	SC-N1/G	SC25BAG-■22	7.5	15	32	32	50	2	2*4
SC-N2	SC35BAA-■22	SC-N2/G	SC35BAG-■22	11	18.5	40	40	60	2	2*4
SC-N2S	SC50BAA-■22	SC-N2S/G	SC50BAG-■22	15	22	50	50	80	2	2*4
SC-N3	SC65BAA-■22	SC-N3/G	SC65BAG-■22	18.5	30	65	65	100	2	2*4
SC-N4	SC80BAA-■22	SC-N4/SE	SC80BAS-■22	22	40	80	80	135	2	2*4
SC-N5	SC93BAA-■22	SC-N5	SC93BAA-■22	30	55	105	105	150	2	2*4
SC-N6	SC1CBAA-■22	SC-N6	SC1CBAA-■22	37	60	125	125	150	2	2*4
SC-N7	SC1FBAA-■22	SC-N7	SC1FBAA-■22	45	75	150	150	200	2	2*4
SC-N8	SC1JBAA-■22	SC-N8	SC1JBAA-■22	55	90	180	180	260	2	2*4
SC-N10	SC2CBAA-■22	SC-N10	SC2CBAA-■22	65	110	220	220	260	2	2*4
SC-N11	SC3ABAA-■22	SC-N11	SC3ABAA-■22	90	160	300	300	350	2	2*4
SC-N12	SC4ABAA-■22	SC-N12	SC4ABAA-■22	120	220	400	400	450	2	2*4
SC-N14	SC6ABAA-■22	SC-N14	SC6ABAA-■22	180	315	600	600	660	2	2*4
SC-N16	SC8ABAA-■22	SC-N16	SC8ABAA-■22	220	440	800	800	800	2	2*4

Notes: \*1 Auxiliary contact 1NC is available on request.

\*2 Auxiliary contact 2NO or 2NC is available on request.

\*3 Auxiliary contact 2NC, 2NO or 2NO+2NC is available on request.

■ Coil voltage code

\*4 Auxiliary contact 4NO+4NC is available on request for frame size N1 and above.

\*5 Conforming to IEC 60947-4-1 AC-3

### Thermal overload relays

Standard Type	Ordering code	2E type Type	Ordering code	Setting current range (A)	Reset	Used with
TR-0N/3 TR-0NH/3	TR13DW-□ TR13DH-□	TK-0N TK-0NH	TR13EW-□ TR13EH-□	0.1–0.15, 0.13–0.2, 0.15–0.24, 0.2–0.3, 0.24–0.36 0.3–0.45, 0.36–0.54, 0.48–0.72, 0.64–0.96, 0.8–1.2 0.95–1.45, 1.4–2.2, 1.7–2.6, 2.2–3.4, 2.8–4.2, 4–6 5–8, 6–9, 7–11, 9–13	Manual/auto	SC-03 SC-0 SC-05
TR-5-1N/3 TR-5-1NH/3	TR20DW-□ TR20DH-□	TK-5-1N TK-5-1NH	TR20EW-□ TR20EH-□	0.1–0.15, 0.13–0.2, 0.15–0.24, 0.2–0.3, 0.24–0.36 0.3–0.45, 0.36–0.54, 0.48–0.72, 0.64–0.96, 0.8–1.2 0.95–1.45, 1.4–2.2, 1.7–2.6, 2.2–3.4, 2.8–4.2, 4–6 5–8, 6–9, 7–11, 9–13, 12–18, 16–22	Manual/auto	SC-4-0 SC-4-1 SC-5-1
TR-N2/3 TR-N2H/3	TR35BDW-□ TR35BDH-□	TK-N2 TK-N2H	TR35BEW-□	4–6, 5–8, 6–9, 7–11, 9–13, 12–18, 18–26 24–36, 32–42	Manual/auto	SC-N1 SC-N2
TR-N3/3 TR-N3H/3	TR65BDW-□ TR65BDH-□	TK-N3 TK-N3H	TR65BEW-□	7–11, 9–13, 12–18, 18–26, 24–36, 28–40 34–50, 45–65, 48–68, 53–80, 65–95, 85–105	Manual/auto	SC-N2S SC-N3
TR-N5/3	TR93BDW-□	TK-N5	TR93BEW-□ TR93BEH-□	18–26, 24–36, 28–40, 34–50, 45–65, 53–80 65–95, 85–105	Manual/auto	SC-N4 SC-N5
TR-N6/3 TR-N6H/3	TR1CBDW-□ TR1CBDH-□	TK-N6 TK-N6H	TR1CBEW-□ TR1CBEH-□	45–65, 53–80, 65–95, 85–125, 110–160	Manual/auto	SC-N6
TR-N7/3	TR1FBDW-□	TK-N7	TR1FBEW-□	45–65, 53–80, 65–95, 85–125, 110–160	Manual/auto	SC-N7
TR-N8/3	TR1JBDW-□	TK-N8	TR1JBEW-□	65–95, 85–125, 110–160, 125–185	Manual/auto	SC-N8
TR-N10/3 TR-N10H/3	TR2CBDW-□ TR2CBDH-□	TK-N10 TK-N10H	TR2CBEW-□ TR2CBEH-□	85–125, 110–160, 125–185, 160–240	Manual/auto	SC-N10
TR-N12/3 TR-N12H/3	TR4ABDW-□ TR4ABDH-□	TK-N12 TK-N12H	TR4ABEW-□ TR4ABEH-□	110–160, 125–185, 160–240, 200–300 240–360, 300–450	Manual/auto	SC-N11 SC-N12
TR-N14/3 TR-N14H/3	TR6ABDW-□ TR6ABDH-□	TK-N14 TK-N14H	TR6ABEW-□ TR6ABEH-□	240–360, 300–450, 400–600	Manual/auto	SC-N14

Note: □ Thermal overload relay ampere setting range code, [see page 01/132](#).

**Optional units (Auxiliary contact blocks)**

Type	Ordering code	Description	Contact arrangement	Continuous current (A)	Operational current (A)				Used with
					AC-15 100–120V	200–240V	380–440V	500–600V	
SZ-A40 SZ-A31 SZ-A22 SZ-A20 SZ-A11 SZ-A02	SZ1A40 SZ1A31 SZ1A22 SZ1A20 SZ1A11 SZ1A02	Front mounting	4NO 3NO+1NC 2NO+2NC 2NO 1NO+1NC 2NC	10	6	3	1.5	1.2	SC-03 to SC-N3
SZ-AS1 SZ-AS2	SZ1AS1 SZ2AS2	Side mounting	1NO+1NC 1NO+1NC						
SZ-AS3H	SZ2AS3H		1NO+1NC						SC-N14, SC-N16

**Contactors FC series**

AC operated		DC operated		Max. motor capacity (kW) *3		Operational current (A) *3		Continuous current (A)	Contact arrangement	
Type	Ordering code	Type	Ordering code	3-phase 200V 240V	380V 440V	3-phase 200V 240V	380V 440V		Main contact	Aux. contact
FC-0UL	SF12B1A-■10	FC-0/GUL	SF12B1G-■10	3.0	2.5	12	6	20	3NO	1NO *1
FC-0TUL	SF12B3A-■10	FC-0T/GUL	SF12B3G-■10	2.2	2.5	12	6	20	3NO	1NO *1
FC-0SUL	SF15B1A-■10	FC-0S/GUL	SF15B1G-■10	3.5	4.5	15	10	20	3NO	1NO *1
FC-0STUL	SF15B3A-■10	FC-0ST/GUL	SF15B3G-■10	3.5	4.5	15	10	20	3NO	1NO *1
FC-1UL	SF20B1A-■11	–	–	5.5	5.5	20	13	30	3NO	1NO+1NC
FC-1SUL	SF26B1A-■11	–	–	7.5	7.5	27	18	30	3NO	1NO+1NC
FC-2SUL	SF35B1A-■11	–	–	11	11	40	26	45	3NO	1NO+1NC *2
FC-3UL	SF50B1A-■11	–	–	15	18.5	52	40	60	3NO	1NO+1NC *2
FC-4UL	SF65B1A-■11	–	–	18.5	30	65	65	80	3NO	1NO+1NC *2

Notes: \*1 Auxiliary contact 1NC is available on request.  
 \*2 Auxiliary contact 2NO or 2NC is available on request.  
 \*3 Conforming to IEC 60497-4-1 AC-3  
 ■ Coil voltage code

# Magnetic Contactors and Starters

## TÜV approved

### Solid-state contactors SS series

#### Single pole type

#### ● Main circuit 240V AC, SS101 to SS2001

Type	SS101-5Z-A3 SS101-5Z-A4 SS101-3Z-D3	SS201-5Z-A3 SS201-5Z-A4 SS201-3Z-D3	SS301-5Z-A3 SS301-5Z-A4 SS301-3Z-D3	SS401-5Z-A3 SS401-5Z-A4 SS401-3Z-D3	SS501-5Z-A3 SS501-5Z-A4 SS501-3Z-D3
Ordering code	SS101-5ZA3 SS101-5ZA4 SS101-3ZD3	SS201-5ZA3 SS201-5ZA4 SS201-3ZD3	SS301-5ZA3 SS301-5ZA4 SS301-3ZD3	SS401-5ZA3 SS401-5ZA4 SS401-3ZD3	SS501-5ZA3 SS501-5ZA4 SS501-3ZD3
Rated thermal current(A) *	10	20	30	40	50
Control voltage	A3 : 100V-120V AC, A4 : 200-240V AC, D3 : 5-24V DC				

Type	SS701-1Z-A3 SS701-1Z-A4 SS701-3Z-D3	SS1001-1Z-A3 SS1001-1Z-A4 SS1001-3Z-D3	SS1501-1Z-A3 SS1501-1Z-A4 SS1501-3Z-D3	SS2001-1Z-A3 SS2001-1Z-A4 SS2001-3Z-D3	
Ordering code	SS701-1ZA3 SS701-1ZA4 SS701-3ZD3	SS1A1-1ZA3 SS1A1-1ZA4 SS1A1-3ZD3	SS1F1-1ZA3 SS1F1-1ZA4 SS1F1-3ZD3	SS1A1-1ZA3 SS1A1-1ZA4 SS1A1-3ZD3	
Rated thermal current(A) *	70	100	150	200	
Control voltage	A3 : 100V-120V AC, A4 : 200-240V AC, D3 : 5-24V DC				

#### ● Main circuit 480V AC, SS701H to SS2001H

Type	SS701H-1Z-A3 SS701H-1Z-A4 SS701H-3Z-D3	SS1001H-1Z-A3 SS1001H-1Z-A4 SS1001H-3Z-D3	SS1501H-1Z-A3 SS1501H-1Z-A4 SS1501H-3Z-D3	SS2001H-1Z-A3 SS2001H-1Z-A4 SS2001H-3Z-D3	
Ordering code	SS701H-1ZA3 SS701H-1ZA4 SS701H-3ZD3	SS1A1H-1ZA3 SS1A1H-1ZA4 SS1A1H-3ZD3	SS1F1H-1ZA3 SS1F1H-1ZA4 SS1F1H-3ZD3	SS1A1H-1ZA3 SS1A1H-1ZA4 SS1A1H-3ZD3	
Rated thermal current(A) *	70	100	150	200	
Control voltage	A3 : 100V-120V AC, A4 : 200-240V AC, D3 : 5-24V DC				

Note: \* The values are maximum ratings that apply at an ambient temperature not exceeding 40°C.

**3-pole type**

● **Main circuit 240V AC**

Contactor				Cooling fin to be combined				Continuous current (A)	Motor ratings	
3-pole, 2-element		3-pole, 3-element		3-pole, 2-element		3-pole, 3-element			3-phase 220V AC 60Hz Capacity (HP)	Full load current (A)
Basic type	Basic ordering code	Basic type	Basic ordering code	Basic type	Basic ordering code	Basic type	Basic ordering code			
<b>SS032</b>	SS032	<b>SS033</b>	SS033	–	–	–	–	3	0.5	1.8
<b>SS082</b>	SS082	<b>SS083</b>	SS083	*	*	*	*	8	0.75	3.2
<b>SS202</b>	SS202	<b>SS203</b>	SS203	<b>SX1-D10</b>	SY1D0	<b>SX1-D10</b>	SY1D0	20	1.5	8
<b>SS302</b>	SS302	<b>SS303</b>	SS303	<b>SX1-D10</b>	SY1D0	<b>SX1-E12</b>	SY1E2	30	2	11
<b>SS402</b>	SS402	<b>SS403</b>	SS403	<b>SX1-D14</b>	SY1D4	<b>SX1-E12</b>	SY1E2	40	3	17.4
<b>SS502</b>	SS502	<b>SS503</b>	SS503	<b>SX1-E12</b>	SY1E2	<b>SX1-E17</b>	SY1E7	50	5	26
<b>SS802</b>	SS802	<b>SS803</b>	SS803	<b>SX1-C12</b>	SY1C2	<b>SX1-C12</b>	SY1C2	80	10	34
<b>SS1202</b>	SS1C2	<b>SS1203</b>	SS1C3	<b>SX1-C12</b>	SY1C2	<b>SX1-C12</b>	SY1C2	120	10	34

Note: \* Cooling fin provided

● **Main circuit 480V AC**

Contactor				Cooling fin to be combined				Continuous current (A)	Motor ratings	
3-pole, 2-element		3-pole, 3-element		3-pole, 2-element		3-pole, 3-element			3-phase 440V AC 60Hz Capacity (HP)	Full load current (A)
Basic type	Basic ordering code	Basic type	Basic ordering code	Basic type	Basic ordering code	Basic type	Basic ordering code			
<b>SS302H</b>	SS302H	<b>SS303H</b>	SS303H	<b>SX1-E12</b>	SY1E2	<b>SX1-E12</b>	SY1E2	30	–	–
<b>SS502H</b>	SS502H	<b>SS503H</b>	SS503H	<b>SX1-E12</b>	SY1E2	<b>SX1-E17</b>	SY1E7	50	10	24
<b>SS802H</b>	SS802H	<b>SS803H</b>	SS803H	<b>SX1-C12</b>	SY1C2	<b>SX1-C12</b>	SY1C2	80	20	48
<b>SS1202H</b>	SS1C2H	<b>SS1203H</b>	SS1C3H	<b>SX1-C12</b>	SY1C2	<b>SX1-C12</b>	SY1C2	120	20	48

● **Input voltage**

100–120/200–240V AC	5–12V DC
100–120V AC	12–24V DC
200–240V AC	5V DC
12/24V DC	100–110/200–220V AC/DC
5–24V DC	12/24V AC/DC

Note: For details, [see page 01/127](#).

# Magnetic Contactors and Starters

## CCC approved

### China Compulsory Certification (CCC)

#### ■ Description

FUJI contactors and thermal overload relays are approved by CCC.

Ratings, dimensions and wiring diagrams are same as standard type.

#### ■ Ordering information

When ordering CCC products, add the suffix (CCC) to the type number.

Example of magnetic contactor:

SC-5-1 220V AC 50Hz 1NO+1NC (CCC)

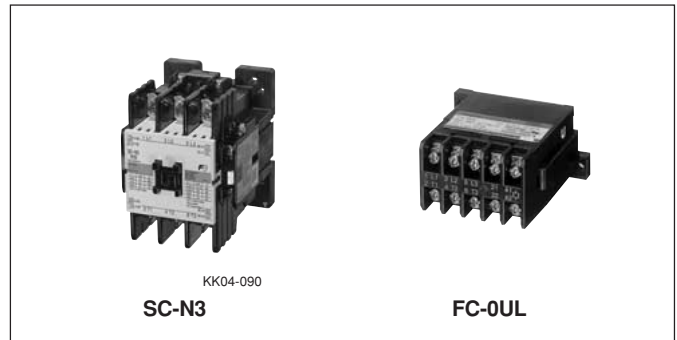

### Magnetic contactors (AC operated, DC operated, With SUPER MAGNET)

AC operated		DC operated		With SUPER MAGNET		Certification number
Non reversing	Reversing	Non reversing	Reversing	Non reversing	Reversing	
Type	Type	Type	Type	Type	Type	
SC-03 SC-0 SC-05	SC-03RM SC-0RM SC-05RM	SC-03/G SC-0/G SC-05/G	SC-03RM/G SC-0RM/G SC-05RM/G	—	—	2003010304063432
SC-4-0 SC-4-1 SC-5-1	SC-4-0RM SC-4-1RM SC-5-1RM	SC-4-0/G SC-4-1/G SC-5-1/G	SC-4-0RM/G SC-4-1RM/G SC-5-1RM/G	—	—	2003010304063438
SC-N1 SC-N2	SC-N1RM SC-N2RM	SC-N1/G SC-N2/G	SC-N1RM/G SC-N2RM/G	SC-N1/SE SC-N2/SE	SC-N1RM/SE SC-N2RM/SE	2003010304063394
SC-N2S SC-N3	SC-N2SRM SC-N3RM	SC-N2S/G SC-N3/G	SC-N2SRM/G SC-N3RM/G	SC-N2S/SE SC-N3/SE	SC-N2SRM/SE SC-N3RM/SE	2003010304067046
SC-N4 SC-N5	SC-N4RM SC-N5RM	—	—	SC-N4/SE	SC-N4RM/SE	2003010304063396
SC-N6	SC-N6RM	—	—	—	—	2003010304063437
SC-N7	SC-N7RM	—	—	—	—	2003010304063436
SC-N8 SC-N10	SC-N8RM SC-N10RM	—	—	—	—	2003010304063435
SC-N11 SC-N12	SC-N11RM SC-N12RM	—	—	—	—	2003010304063393
SC-N14 SC-N16	SC-N14RM —	— —	— —	— —	— —	2003010304067052



**Magnetic contactors** (With extra pick-up operating coil, with high capacity auxiliary contact)

With extra pick-up operating coil		With high capacity auxiliary contact (single button contact)		Certification number
Non reversing	Reversing	Non reversing	Reversing	
Type	Type	Type	Type	
SC-03/U SC-0/U SC-05/U	SC-03RM/U SC-0RM/U SC-05RM/U	SC-03H SC-0H SC-05H	SC-03HRM SC-0HRM SC-05HRM	2003010304063432
SC-4-0/U SC-4-1/U SC-5-1/U	SC-4-0RM/U SC-4-1RM/U SC-5-1RM/U	SC-4-0H SC-4-1H SC-5-1H	SC-4-0HRM SC-4-1HRM SC-5-1HRM	2003010304063438
SC-N1/U SC-N2/U	SC-N1RM/U SC-N2RM/U	SC-N1H SC-N2H	SC-N1HRM SC-N2HRM	2003010304063394
SC-N2S/U SC-N3/U	SC-N2SRM/U SC-N3RM/U	SC-N2SH SC-N3H	SC-N2SHRM SC-N3HRM	2003010304067046
SC-N4/U –	SC-N4RM/U –	SC-N4H SC-N5H	SC-N4HRM SC-N5HRM	2003010304063396
–	–	SC-N6H	SC-N6HRM	2003010304063437
–	–	SC-N7H	SC-N7HRM	2003010304063436
–	–	SC-N8H SC-N10H	SC-N8HRM SC-N10HRM	2003010304063435
–	–	SC-N11H SC-N12H	SC-N11HRM SC-N12HRM	2003010304063393

**FC series magnetic contactors**

AC operated		DC operated		Certification number
Standard	UL, CSA approved	Standard	UL, CSA approved	
Type	Type	Type	Type	
FC-0 FC-0T FC-0S FC-0ST	FC-0UL FC-0TUL FC-0SUL FC-0STUL	FC-0/G FC-0T/G FC-0S/G FC-0ST/G	FC-0/GUL FC-0T/GUL – –	2003010304088942
FC-1 FC-1S	FC-1UL FC-1SUL	– –	– –	2003010304088935
FC-2S FC-3	FC-2SUL FC-3UL	– –	– –	2003010304088929
FC-4	FC-4UL	–	–	2003010304088923

# Magnetic Contactors and Starters

## CCC approved

### Optional units (Auxiliary contact block)

Description		Type	Applicable	Certification number
Front mounting	Bifurcated contact	SZ-A40 SZ-A31 SZ-A22 SZ-A20 SZ-A11 SZ-A02	SC-03 to SC-N3 SH-4, 5	Certified by combination product in the applicable contactor/relay.
	Single button contact	SZ-A40H SZ-A31H SZ-A22H	SC-03 to SC-N3 SH-4, 5	
Side mounting	Bifurcated contact	SZ-AS1	SC-03 to SC-N3 SH-4, 5	
		SZ-AS2	SC-N4 to SC-N12	
	Single button contact	SZ-AS1H	SC-03 to SC-N3 SH-4, 5	
		SZ-AS2H	SC-N4 to SC-N12	
	SZ-AS3H	SC-N14, SC-N16		

### Thermal overload relays

Standard type		With phase-loss protection device		Auto reset type		Certification number
On-contactor mounting type	Separate mounting type	On-contactor mounting type	Separate mounting type	On-contactor mounting type	Separate mounting type	
TR-0N/3	TR-0NH/3	TK-0N	TK-0NH	TR-0N/3A	TR-0NH/3A	2003010304063397
TR-5-1N/3	TR-5-1NH/3	TK-5-1N	TK-5-1NH	TR-5-1N/3A	TK-5-1NH/3A	2003010304063400
TR-N2/3	TR-N2H/3	TK-N2	TK-N2H	TR-N2/3A	TR-N2H/3A	2003010304063425
TR-N3/3 TR-N5/3	TR-N3H/3 -	TK-N3 TK-N5	TK-N3H	TR-N3/3A TR-N5/3A	TR-N3H/3A -	2003010304063404
TR-N6/3 TR-N7/3 TR-N8/3	TR-N6H/3 - -	TK-N6 TK-N7 TK-N8	TK-N6H - -	TR-N6/3A TR-N7/3A TR-N8/3A	TR-N6H/3A - -	2003010304063447
TR-N10/3	TR-N10H/3	TK-N10	TK-N10H	TR-N10/3A	TR-N10H/3A	2003010304063429
TR-N12/3	TR-N12H/3	TK-N12	TK-N12H	TR-N12/3A	TR-N12H/3A	2003010304063434
TR-N14/3	TR-N14H/3	TK-N14	TK-N14H	TR-N14/3A	TR-N14H/3A	2003010304063406

### Thermal overload relays (Quick operation)

Quick operation		Certification number
On-contactor mounting type	Separate mounting type	
TR-0NQ	TR-0NQH	2003010304063397
TR-5-1NQ	TR-5-1NQH	2003010304063400
TR-N2Q	TR-N2QH	2003010304063425
TR-N3Q TR-N5Q	TR-N3QH -	2003010304063404

Note: Quick operation type with phase-loss protection device is available.

### Thermal overload relays (Used with FC series contactor)

Type	Certification number
TR-0NF/3, TK-0NF, TR-0NFQ, TK-0NFQ	2003010304063397
TR-5-1N/3, TK-5-1N, TR-5-1NQ, TK-5-1NQ	2003010304063400
TR-N2F/3, TK-N2F, TR-N2FQ, TK-N2FQ	2003010304063425
TR-N3/3, TK-N3, TR-N3Q, TK-N3Q	2003010304063404

**SJ series magnetic contactors and starters**  
 Up to 4kW 440 Volts AC

■ **Description**

SJ type contactor adopts the operating magnet mechanism in which an electromagnet and a permanent magnet are combined, thus allowing the coil power consumption to be reduced.

The contactor can be operated directly by the DC output of programmable controller or electronic equipment.

Reversing contactor and starter are also available. SJ-1SG and SJ-1SWG types are applicable to three-phase motors of 220 Volts AC, 4.5kW which can be driven directly by semiconductor output.

■ **Features**

- Low power consumption (0G, 06G: 1.4W, 1SG: 2.4W) as well as standard DC-operated models
- High contact reliability  
 Provided with bifurcated auxiliary contacts, thus enabling to be inputted to the electronic circuit directly. They can be used in low level circuit of 5V, 3mA.

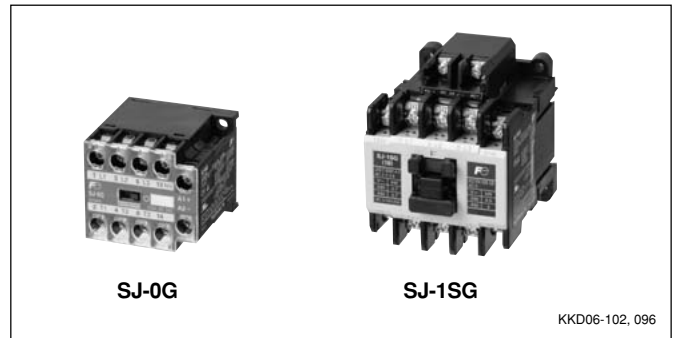

- Surge suppression  
 Provided with a built-in surge suppression circuit, which suppresses the coil surge voltage to 50V or less and 60V or less (SJ-1SG only)
- Rail mounting  
 Direct snap-on mounting on 35mm rails

■ **Types number nomenclature**

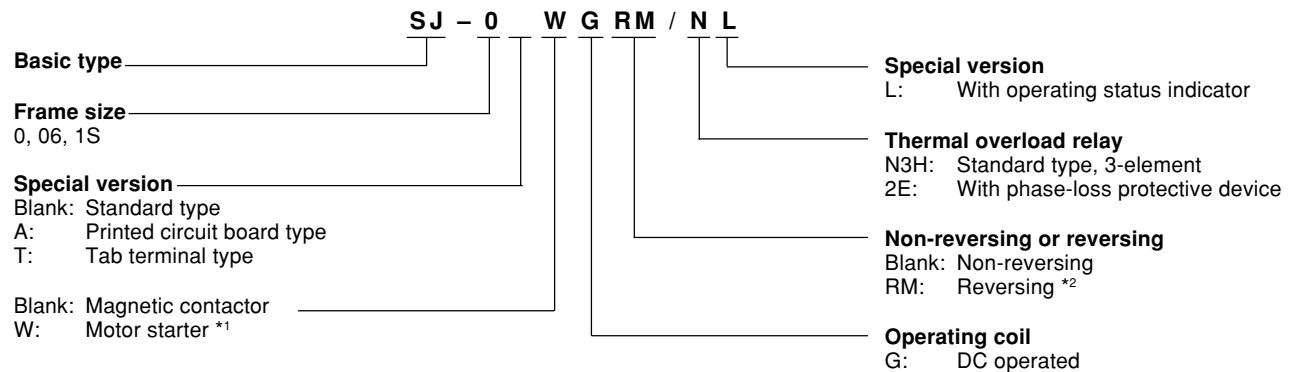

\*1 Magnetic contactors (SJ-□G) and thermal overload relays (TR-□N) have actual type names on nameplates.

\*2 Open type reversing magnetic contactors (SJ-□GRM) and motor starters (SJ-□WGRM) have no type name on their nameplates describing them as reversing types.

\*3 UL and CSA approved is standard.

# Magnetic Contactors and Starters

## SJ series

### Version

Description			Type	Frame size		
				0	06	1S
Contactor	Without indicating lamp	Non reversing Reversing	SJ-□G SJ-□GRM	● ●	● ●	● ●
	With indicating lamp	Non reversing Reversing	SJ-□G/L SJ-□GRM/L	- -	● ●	- -
Starter	Without indicating lamp	Non reversing with OLR*	SJ-□WG/3H	-	-	●
		Non reversing with TR-0N/3Z716	SJ-□WG/N3H	●	●	-
Non reversing with 2E OLR*		SJ-□WG/2E	●	●	●	
Reversing with OLR*		SJ-□WGRM/3H	-	-	●	
Reversing with TR-0N/3Z716		SJ-□WGRM/N3H	●	●	-	
Reversing with 2E OLR*		SJ-□WGRM/2E	●	●	●	
With indicating lamp	Non reversing with TR-0N/3Z716 Non reversing with 2E OLR* Reversing with TR-0N/3Z716 Reversing with 2E OLR*	SJ-□WG/N3HL	-	●	-	
		SJ-□WG/2EL	-	●	-	
		SJ-□WGRM/N3HL	-	●	-	
		SJ-□WGRM/2EL	-	●	-	

Note: "OLR" means thermal overload relay

□: Frame size 0, 06, 1S

### Types and ratings (IEC 60947-4-1)

Motor capacity (kW) AC-3 3-phase		Operational current (A) AC-3 3-phase		Operational current (A) AC-1	Thermal current (A)	Auxiliary contact		Non-reversing Open Type	Reversing Open Type
200V 240V	380V 440V	200V 240V	380V 440V			NO	NC		
3	2.2	12	6	15	15	1	-	SJ-0G SJ-0G	- SJ-0GRM
3	2.2	12	6	15	15	2	1	SJ-06G SJ-06G	SJ-06GRM SJ-06GRM
4.5	4	18	9	25	25	2	-	SJ-1SG SJ-1SG	- SJ-1SGRM

### Auxiliary contact ratings (IEC 60947-5-1)

Frame size	Rated thermal current (A)	Voltage (V AC)	Making & breaking capacity (A)	Rated operation current (A)		Min. operational voltage and current
				Inductive AC-15	Resistive AC-12	
0G	6	200-240 380-440	20 20	2 1	6 6	5V DC, 3mA
06G	6	200-240 380-440	20 20	2 1	6 (3) *1 6 (3) *1	5V DC, 3mA
1SG	10	200-240 380-440	33 16.5	3 1.5	8 5	5V DC, 3mA

\*1 ( ) indicates the current for additional auxiliary contact.

### Thermal overload relays

Thermal overload relay No. of element	Type	Contactor to be used	Setting current Range (A)		
3	TR-0N/3Z716 TK-0NZ716	SJ-0G SJ-06G SJ-06G/L	0.1 - 0.15	0.46 - 0.72	2.8 - 4.2
			0.13 - 0.2	0.64 - 0.96	4 - 6
			0.15 - 0.24	0.8 - 1.2	5 - 8
3	TR-5-1N/3 TK-5-1N	SJ-1SG	0.2 - 0.3	0.95 - 1.45	6 - 9
			0.24 - 0.36	1.4 - 2.2	7 - 11
			0.3 - 0.45	1.7 - 2.6	9 - 13*
			0.36 - 0.54	2.2 - 3.4	12 - 18*

Manual reset type is standard. Auto reset type is available on request.

Note: \* For SJ-1SWG only.

■ Performance data

Basic type	Voltage (V AC)	Operating current (A)	Making and breaking current (A)		Operating cycles per hour	Life expectancy (operations)	
			Making	Breaking		Mechanical	Electrical
SJ-0G	220	12	120	96	1800	10 millions	1 millions
SJ-06G	440	6	60	48			
SJ-1SG	220	18	180	144	1800	10 millions	2 millions
	440	9	90	72			

■ Operating coil

Type	Voltage (V DC)	Power consumption (W)	Wiring
SJ-0G	12	1.4	
SJ-06G		1.4	
SJ-1SG	24	2.4	SJ-0G, 06G      SJ-1SG

Note: Operating voltage range  
 SJ-0G, 06G: 85-120% of rated voltage  
 SJ-1SG: 85-110% of rated voltage

■ Dimensions, mm  
Magnetic contactor, open type

SJ-0G



Mass: 0.17kg

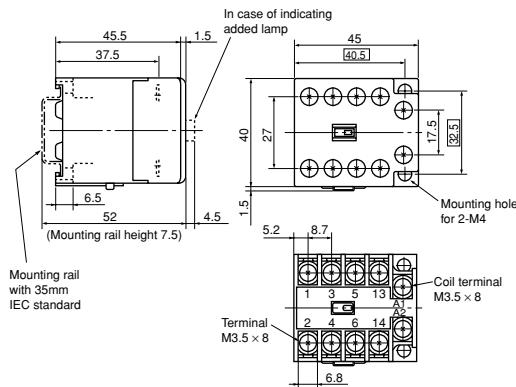

SJ-0G

(Aux. contact)

1NO

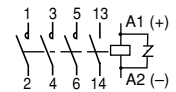

1NC

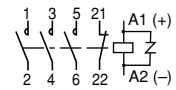

SJ-06G



Mass: 0.19kg

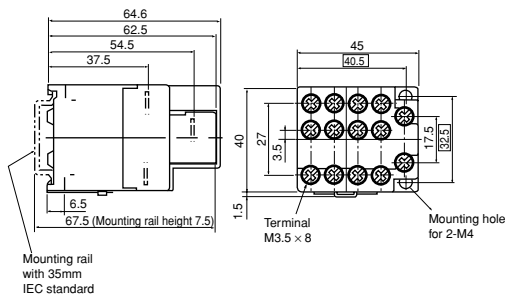

SJ-06G

3NO

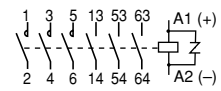

2NO1NC

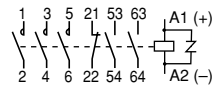

1NO2NC

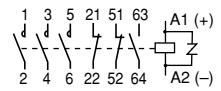

SJ-1SG



Mass: 0.5kg

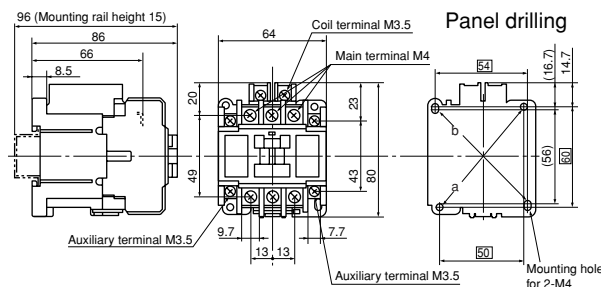

SJ-1SG

2NO

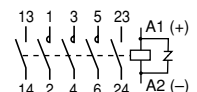

1NO1NC

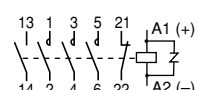

Note: • Use the two mounting holes on a diagonal line to mount a contactor.  
 Mounting holes indicated by a are compatible with those of SRC type.  
 Mounting holes indicated by b are compatible with IEC standard.

# Magnetic Contactors and Starters

## SJ series

**■ Dimensions, mm**  
**Magnetic starter, open type**

**SJ-0WG/N3H, SJ-0WG/2E**



Mass: 0.3kg

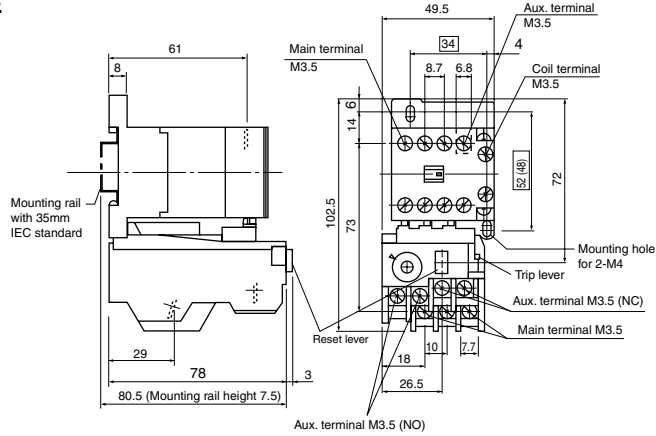

**■ Wiring diagrams**

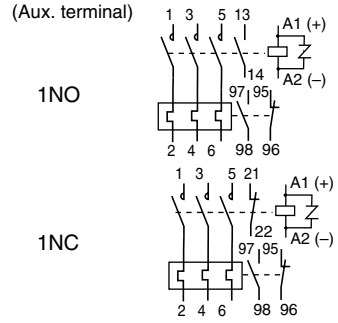

**SJ-06WG/N3H, SJ-06WG/2E, SJ-06WG/N3HL, SJ-06WG/2EL**



Mass: 0.32kg

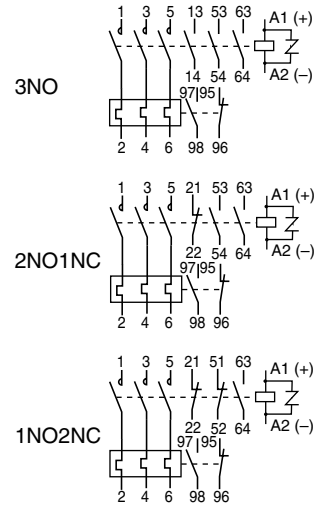
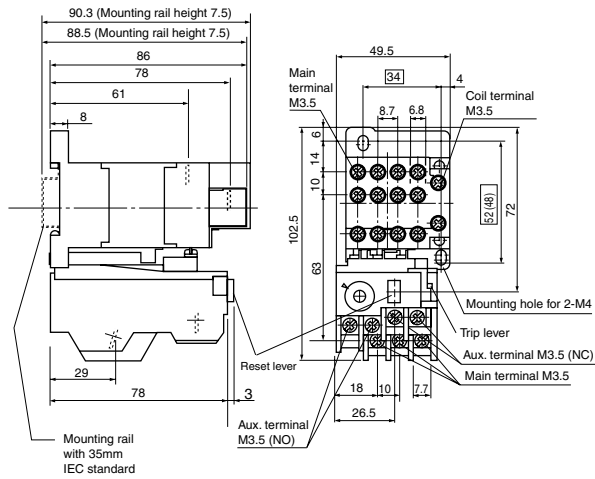

**SJ-1SWG/3H, SJ-1SWG/2E**



Mass: 0.62kg

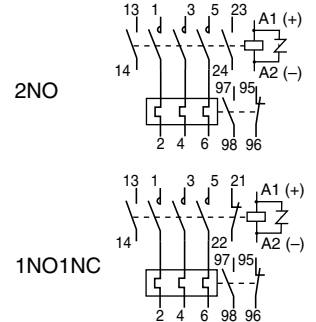
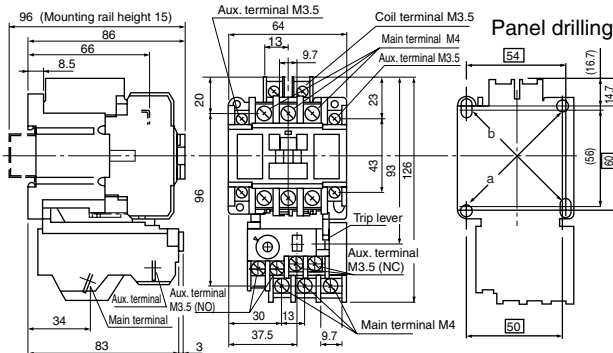

Note: • Use the two mounting holes on a diagonal line to mount a contactor.  
Mounting holes indicated by a are compatible with those of SRC type.  
Mounting holes indicated by b are compatible with IEC standard.

### **Catalog Disclaimer**

The information contained in this catalog does not constitute an express or implied warranty of quality, any warranty of merchantability or fitness for a particular purpose is hereby disclaimed.

Since the user's product information, specific use application, and conditions of use are all outside of Fuji Electric FA Components & Systems' control, **it shall be the responsibility of the user to determine the suitability of any of the products mentioned for the user's application.**

### **One Year Limited Warranty**

The products identified in this catalog shall be sold pursuant to the terms and conditions identified in the "Conditions of Sale" issued by Fuji Electric FA with each order confirmation.

Except to the extent otherwise provided for in the Conditions of Sale issued by Fuji Electric FA, Fuji Electric FA warrants that the Fuji Electric FA products identified in this catalog shall be free from significant defects in materials and workmanship provided the product has not been: 1) repaired or altered by others than Fuji Electric FA; 2) subjected to negligence, accident, misuse, or damage by circumstances beyond Fuji Electric FA's control; 3) improperly operated, maintained or stored; or 4) used in other than normal use or service. This warranty shall apply only to defects appearing within one (1) year from the date of shipment by Fuji Electric FA, and in such case, only if such defects are reported to Fuji Electric FA within thirty (30) days of discovery by purchaser. Such notice should be submitted in writing to Fuji Electric FA at 5-7, Nihonbashi Odemma-cho, Chuo-ku, Tokyo, Japan. The sole and exclusive remedy with respect to the above warranty whether such claim is based on warranty, contract, negligence, strict liability or any other theory, is limited to the repair or replacement of such product or, at Fuji Electric FA's option reimbursement by Fuji Electric FA of the purchase price paid to Fuji Electric FA for the particular product. **Fuji Electric FA does not make any other representations or warranties, whether oral or in writing, expressed or implied, including but not limited to any warranty regarding merchantability or fitness for a particular purpose.** Except as provided in the Conditions of Sale, no agent or representative of Fuji Electric FA is authorized to modify the terms of this warranty in writing or orally.

In no event shall Fuji Electric FA be liable for special, indirect or consequential damages, including but not limited to, loss of use of the product, other equipment, plant and power system which is installed with the product, loss of profits or revenues, cost of capital, or claims against the purchaser or user of the product by its customers resulting from the use of information, recommendations and descriptions contained herein. The purchaser agrees to pass on to its customers and users, in writing at the time inquiries and orders are received by buyer, Fuji Electric FA's warranty as set forth above.

### **Caution "Safety precautions"**

- Operate (keep) in the environment specified in the operating instructions and manual. High temperature, high humidity, condensation, dust, corrosive gases, oil, organic solvents, excessive vibration or shock might cause electric shock, fire, erratic operation or failure.
- Follow the regulations of industrial wastes when the product is to be discarded.
- The products covered in this catalogs have not been designed or manufactured for use in equipment or systems which, in the event of failure, can lead to loss of human life.
- If you intend to use the products covered in this catalog for special applications, such as for nuclear energy control, aerospace, medical, or transportation, please consult our Fuji Electric FA agent.
- Be sure to provide protective measures when using the product covered in these catalogs in equipment which, in the event of failure, may lead to loss of human life or other grave results.
- Follow the directions of the operating instructions when mounting the product.

# 01

## INDIVIDUAL CATALOG

from D&C CATALOG 19th Edition Revised

### **Fuji Electric FA Components & Systems Co., Ltd.**

5-7, Nihonbashi Odemma-cho, Chuo-ku, Tokyo 103-0011, Japan

URL <http://www.fujielectric.co.jp/fcs/eng>

Information in this catalog is subject to change without notice.



Printed on 100% recycled paper using soy-based ink