

**MINIRAIL**

**Mounting instructions**

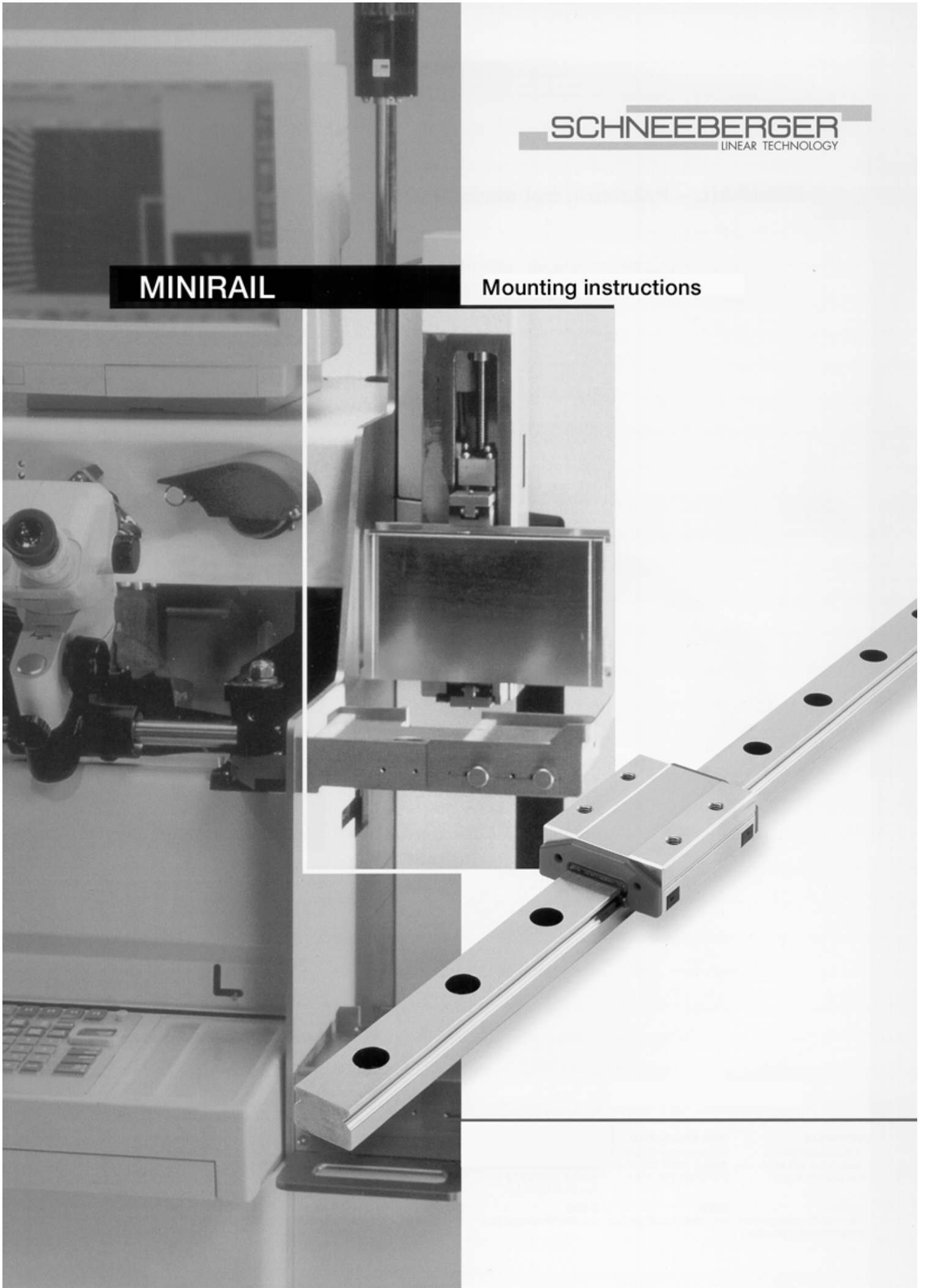

## Contents

<b>1</b>	<b>Information on these assembly instructions.....</b>	<b>4</b>
1.1	Function and validity .....	4
1.2	Target group .....	4
1.3	Other literature .....	4
<b>2</b>	<b>For your safety.....</b>	<b>5</b>
2.1	Authorized persons.....	5
2.2	Correct use.....	5
2.3	General safety and protection measures.....	5
2.4	Environmentally responsible behavior .....	5
<b>3</b>	<b>Description .....</b>	<b>6</b>
3.1	Components.....	6
<b>4</b>	<b>Transport and storage .....</b>	<b>7</b>
<b>5</b>	<b>Preparations for assembly.....</b>	<b>7</b>
5.1	Tools and auxiliary equipment required.....	7
5.2	Checking the scope of delivery .....	7
5.3	Preparing the locating sides.....	7
5.4	Determining installation variants .....	8
<b>6</b>	<b>Installation .....</b>	<b>9</b>
6.1	Important information on installation .....	9
6.2	Installation variant 1 .....	10
6.3	Installation variant 2 .....	11
6.4	Installation variant 3 .....	12
<b>7</b>	<b>Maintenance .....</b>	<b>13</b>
7.1	Cleaning .....	13
7.2	Running the carriage on and off the rail.....	13
7.3	Exchange of the front plates .....	13
<b>8</b>	<b>Appendix.....</b>	<b>14</b>
8.1	Tightening torques for rails and carriages.....	14
8.2	Lubrication.....	14
<b>9</b>	<b>SCHNEEBERGER-Group .....</b>	<b>15</b>

# 1 Information on these assembly instructions

## 1.1 Function and validity

The MINIRAIL assembly instructions describe how to assemble the profile rail guide systems.

## 1.2 Target group

SCHNEEBERGER has defined the following user groups:

- Product manufacturers
- Product users

The product manufacturer is the direct customer of SCHNEEBERGER. The product manufacturer installs the SCHNEEBERGER system in his machine and sells the end product to the product user.

These assembly instructions are intended for the product manufacturer.

## 1.3 Other literature

MINIRAIL product catalog

## 2 For your safety

### 2.1 Authorized persons

MINIRAIL may only be installed by specialists who have the necessary training, e.g. assemblers who have read and understood these instructions.

### 2.2 Correct use

MINIRAIL is used for precision linear movements.

MINIRAIL may only be used within the defined temperature range.

### 2.3 General safety and protection measures

**Storage** Store the MINIRAIL in its original packing until it is installed, and protect it against moisture and damage.

**Assembly** During installation, all components must be the same room temperature.

**Repairs** Use only SCHNEEBERGER original parts for repair work.

**Miscellaneous** Country-specific regulations, standards and directives on accident prevention must be observed.  
SCHNEEBERGER accepts no liability for damage resulting from unauthorized modifications to the MINIRAIL.

### 2.4 Environmentally responsible behavior

Do not allow lubricants to escape into the environment and dispose of them in an environmentally responsible way.

### 3 Description

#### 3.1 Components

##### MINIRAIL-System

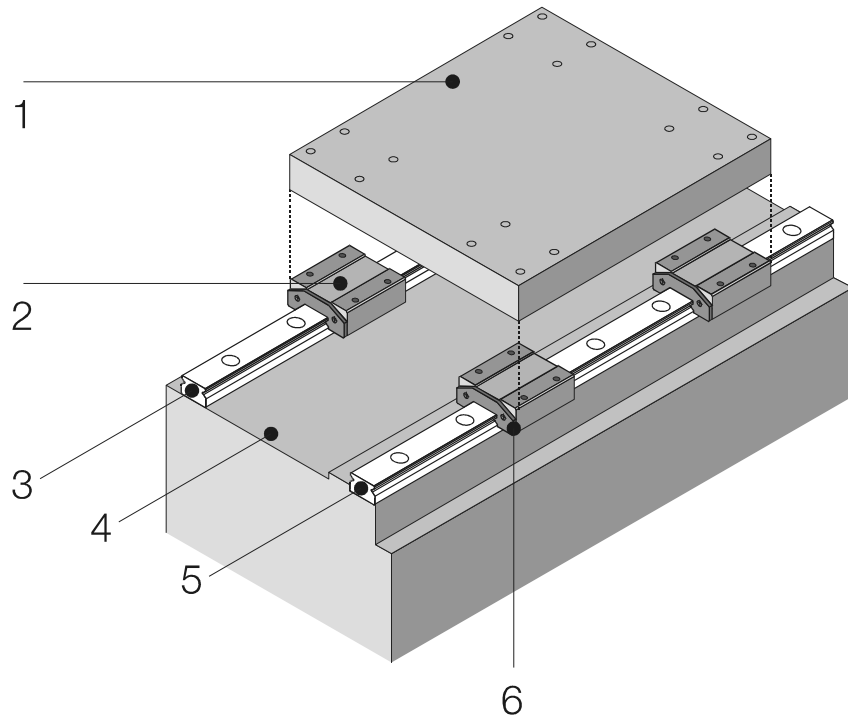

- 1 Mounting plate
- 2 Carriage
- 3 Rail 2
- 4 Machine bed
- 5 Rail 1 (reference rail, positioned on the stop surface in the machine bed)
- 6 Exchangeable front plate

##### MINIRAIL cross sections

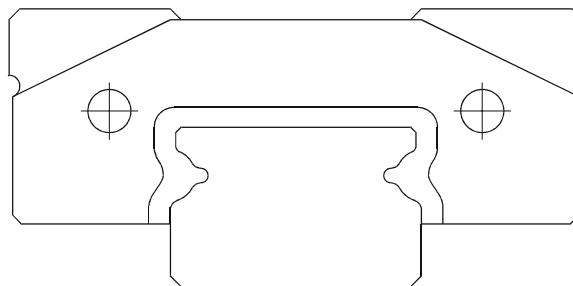

## 4 Transport and storage

Always pay attention to the following when transporting and storing MINIRAIL:

- Transport in the original packaging.
- Protect against impacts and moisture.

## 5 Preparations for assembly

### 5.1 Tools and auxiliary equipment required

- Oilstone
- Lubricant
- Torque wrench
- Fastening screws for the rails and carriages

### 5.2 Checking the scope of delivery

The MINIRAIL carriages and rails are delivered separately packed.. The carriages are mounted on a protection rail. Check the components for completeness and condition.

### 5.3 Preparing the locating sides

1. Check the locating sides of the machine bed and mounting plate for dimensional and position accuracy. If these do not meet the requirements, have the locating sides reworked.

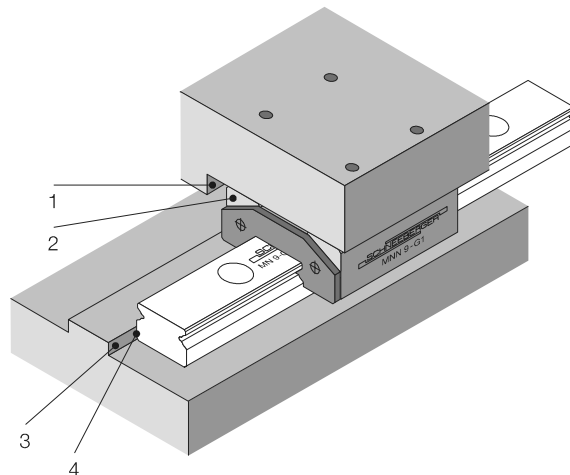

- 1 Locating side, mounting plate
- 2 Locating side, carriage
- 3 Locating side, machine bed
- 4 Locating side, rail

➔ Note: Both rail sides can be used as locating sides.

2. Clean all locating sides thoroughly. Remove burrs and unevenness with an oilstone
3. Clean the locating and support sides of the rails and carriages using naphtha or mineral spirits. Do **not** use nitro!
4. Lightly oil the locating sides on the rails and carriages..

#### 5.4 Determining installation variants

Different installation variants are recommended, depending on the requirements for the accuracy and the rigidity of the rails. These differ by may of customer-specific locating sides and therefore by may of the lateral guide.

3 typical installation variants are described in more detail below:

##### Installation variant 1

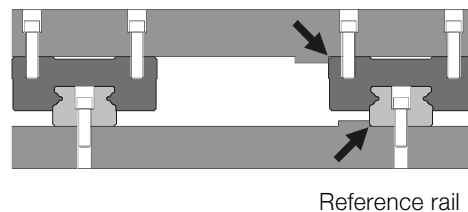

- On the side of the reference rail locating sides between machine bed and rails, mounting plate and carriage
- Mounting plate screwed onto the carriage from above

##### Installation variant 2

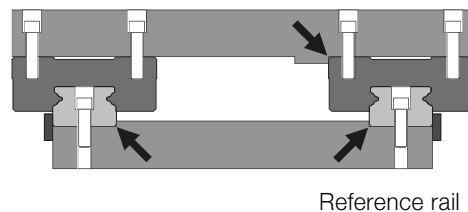

- On both rail sides locating sides between the machine bed and rail
- On the reference rail side locating sides between the mounting plate and carriage
- Mounting plate screwed onto the carriage from above

##### Installation variant 3

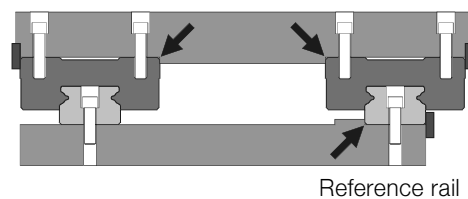

- On the side of the reference rail locating side between machine bed and rail
- On both rail sides locating sides between the mounting plate and carriage
- Mounting plate screwed onto the carriage from above

The rail which is placed on a locating side of the machine bed is designated the **reference rail** (rail 1).

## 6 Installation

### 6.1 Important information on installation

- Handling rails**
- The rails, machine bed, mounting plate and fastening screws must have the same room temperature at the start of installation.
  - Always clamp the rails with their locating side against the locating side of the machine bed.  
Both rail sides can be used as locating side.
  - For high running accuracy and a good screw head position, grease the contact surface and the thread of the fastening screws with grease containing MoS<sub>2</sub>.
  - **Always** tighten the fastening screws with a torque wrench.  
See section 8.1 for the tightening torques.
  - Tighten the fastening screws **alternately** from the rail center and the rail train center.

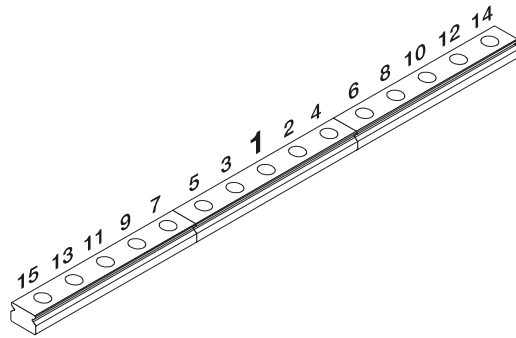

- Handling carriages**
- If possible, always leave the carriages on the rail. To run a carriage on and off for MONORAIL MR, use a mounting rail, see section 7.2.
  - Always clamp the locating sides of the carriages against the locating sides of the mounting plate. The locating side of the carriage is the side opposite to the one with SCHNEEBERGER and the type indication.



## 6.2 Installation variant 1

1. Clamp the reference rail against the locating side of the machine bed and screw its securely into place, see section 6.

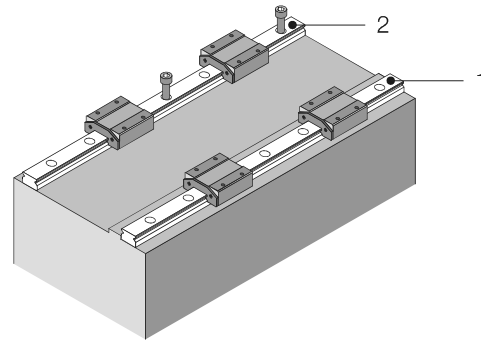

- 1 Reference rail
- 3 Opposite rail

2. Align the opposite rail parallel and provisionally secure it.
3. Place the mounting plate on the carriages and gently tighten the fastening screws.
4. Clamp the mounting plate against the locating sides of the carriages on the secured reference rail and screw securely into place.

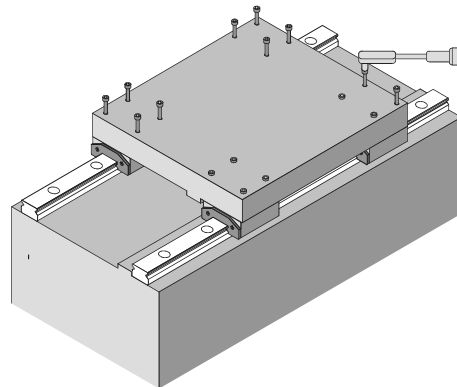

5. Securely screw a carriage on the not yet fastened rail on the mounting plate.

6. Slide the mounting plate with the carriage backwards and forwards and tighten the fastening screws of the unsecured rail securely next to the carriage, see section 6.1.

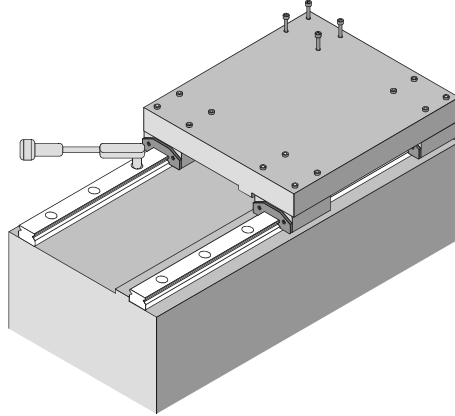

7. Securely screw on the mounting plate.

### 6.3 Installation variant 2

1. Clamp both rails against the locating sides and securely screw them into place, see section 6.1.
2. If necessary, fit clamping screws, clamping bars or conical bars.
3. Place the mounting plate on the carriage
4. Clamp the mounting plate against the locating sides of the carriage on the reference rail and securely screw it to these two carriages.

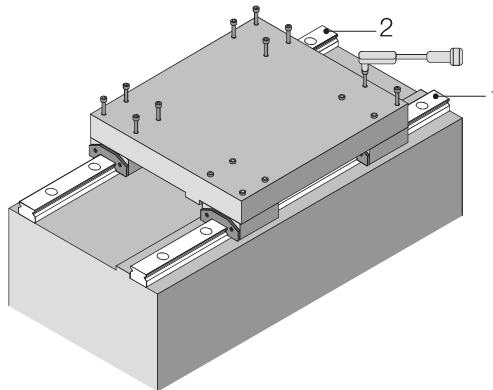

- 1 Reference rail
- 2 Opposite rail

5. Slide the mounting plate with carriage once over the entire rail length.
6. Securely screw the mounting plate into place.

## 6.4 Installation variant 3

1. Clamp the reference rail against the locating side and screw it securely into place, see section 6.1.

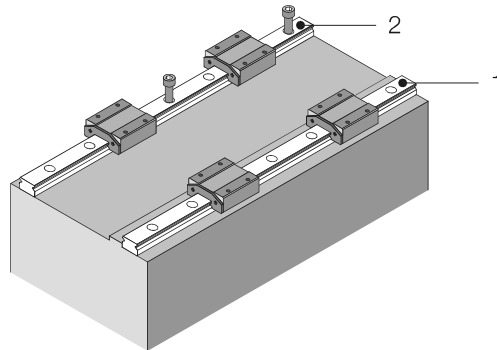

- 1 Reference rail
- 2 Opposite rail

2. Align the opposite rail parallel and provisionally secure it.
3. Place the mounting plate onto the carriages and gently tighten all fastening screws.
4. Clamp the mounting plate on every rail side against the locating sides of the carriages and securely screw into place.

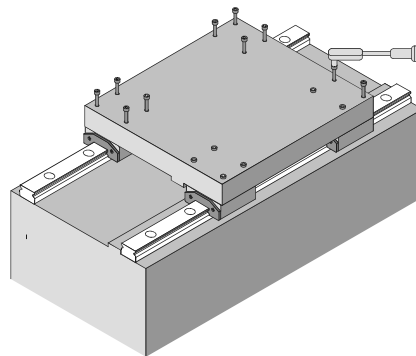

5. If necessary, fit clamping screws clamping bars or conical bars.
6. Slide the mounting plate with the carriages backwards and forwards and tighten the fastening screws of the unscrewed rail securely next to the carriage, see section 6.1.

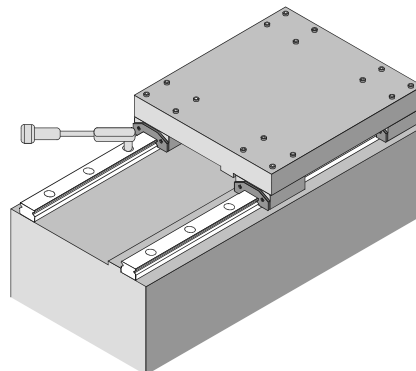

## 7 Maintenance

### 7.1 Cleaning

- Clean only with mineral spirits. Do **not** use nitro!
- Clean dirty rails with a soft, lint-free cloth or fabric cloth. Do **not** use compressed air!

### 7.2 Running the carriage on and off the rail

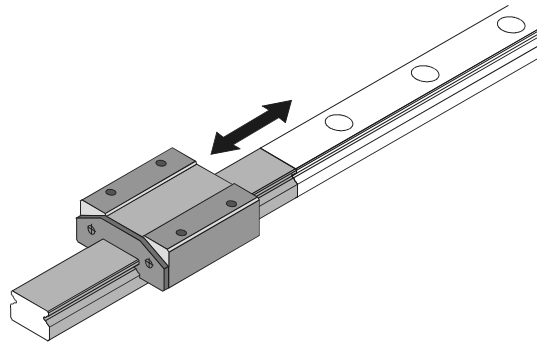

### 7.3 Exchange of the front plates

Front plates are attached with clips and can be exchanged.

## 8 Appendix

### 8.1 Tightening torques for rails and carriages

Strengthclass	Max. tightening torques in Nm for fastening screws DIN 912 = 0,125 (12.9) und DIN 912 = 0,2 (A2-70)		
	M2	M3	M4
12.9	0.6	2.1	5.0
A2-70	0.3	1.1	2.6

#### Notes

- When the screws are greased with grease containing MoS<sub>2</sub> the friction coefficient  $\mu$  can be reduced by as much as half. As the tightening torques required to reach the maximum permissible tightening force depend on the friction coefficient, they must be reduced accordingly. The values can be obtained from the screw manufacturer's information or from the specialist literature. If necessary, carry out tests to determine the actual friction coefficient.
- Refer to the screw manufacturer's information. This is always binding.

### 8.2 Lubrication

The front plates include two lubrication holes to allow independent lubrication for the right and left side of the carriage. This ensures that all tracks of the carriage are provided with lubricant, in all installation orientations. At delivery the carriages are slightly oiled. The required re-lubrication intervals as well as a lubrication prior to operation depend on the application and the operating conditions.

For lubrication with oil SCHNEEBERGER recommends mineral oil CLP (DIN 51517) or HLP (DIN 51524) in the viscosity range of ISO VG32 to ISO VG100 in accordance with DIN 51519. For the lubrication with grease, SCHNEEBERGER recommends grease KP2K or KP1K in accordance with DIN 51825.

**Attention: During greasing the carriage should be moved several times for the lubricant is spread.**

A re-lubrication set with an appropriate oil can be ordered at SCHNEEBERGER with the ordering code MNW.



## 9 SCHNEEBERGER-Group

<b>Switzerland</b>	W. Schneeberger AG St. Urbanstrasse 12 <b>4914 Roggwil</b>	Phone 062 918 41 11 Fax 062 918 41 00 E-Mail info-ch@schneeberger.com
<b>Germany</b>	Schneeberger GmbH Gräfenau, Postfach 70 <b>75339 Höfen/Enz</b>	Phone 07081 782-0 Fax 07081 782-124 E-Mail info-d@schneeberger.com
<b>France</b>	Schneeberger Sarl Technique Linéaire Z.. de la Moinerie 15, rue du Roussillon, B.P. 07 <b>91222 Brétigny/Orge-Cedex</b>	Phone 01 69 88 50 00 Fax 01 60 84 96 02 E-Mail info-f@schneeberger.com
<b>Italy</b>	Schneeberger S.p.A. Via S. Gottardo, 10 <b>21021 Angera VA</b>	Phone 07081 782-0 Fax 07081 782-124 E-Mail info-i@schneeberger.com
<b>USA</b>	Schneeberger Inc. 11 DeAngelo Drive <b>Bedford, MA 01730</b>	Phone 781-271-0140 800-854-6333 Fax 781-275-4749 E-Mail info-usa@schneeberger.com
<b>Japan</b>	Nippon Schneeberger K.K. 967-1 Kamigou, Ebina-shi <b>Kanagawa 243-0434</b>	Phone 0462-35-2140 Fax 0462-35-2142 E-Mail info-j@schneeberger.com

More information at [www.schneeberger.com](http://www.schneeberger.com)