

NEW

High-temperature LM Guide Series

Maximum permissible temperature: 150°C

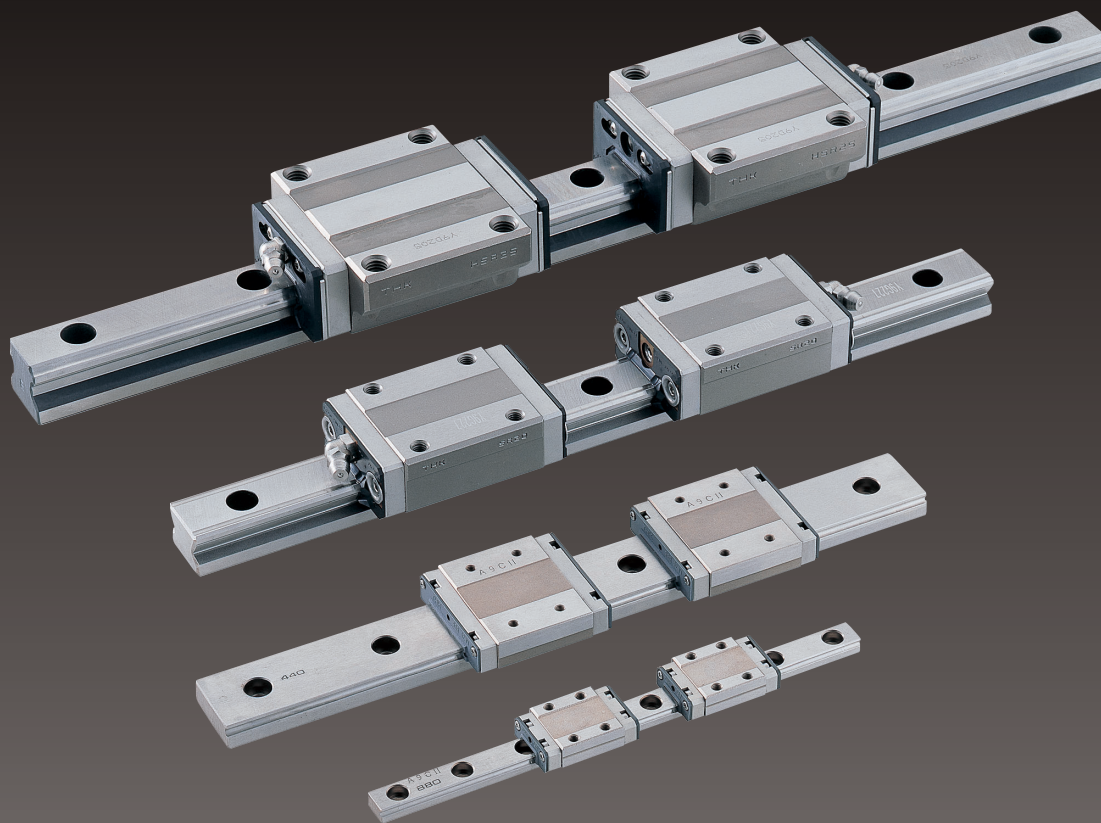

THK High-temperature LM Guide

■ THK has developed its new line of High-temperature LM Guides for high-temperature applications.

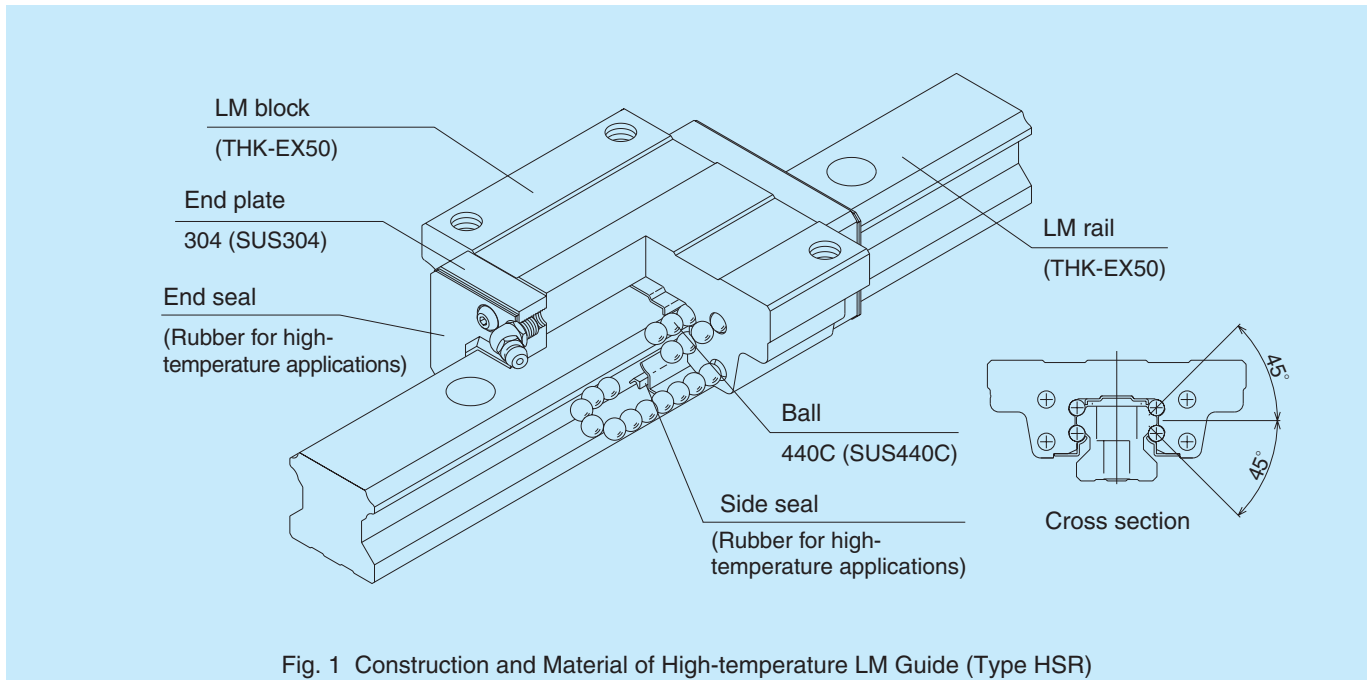

Construction and Features

- **High maximum permissible temperature: 150°C**
The stainless steel end plate and high-temperature rubber seals allow the Guide to be used under high temperatures.
- **High dimensional stability**
A special treatment minimizes dimensional fluctuations (except for thermal expansion at high temperatures).
- **Corrosion-resistant**
The Guide is made entirely of stainless steel.
- **Heat-resistant grease**
High-temperature grease (fluorine-based) is sealed in.
- **Heat-resistant seal**
High-temperature rubber used for the seals make them durable in hot environments.

Dimensional Stability Data

A special treatment to maintain dimensional stability minimizes dimensional variations due to heating and cooling.

LM rail overall length

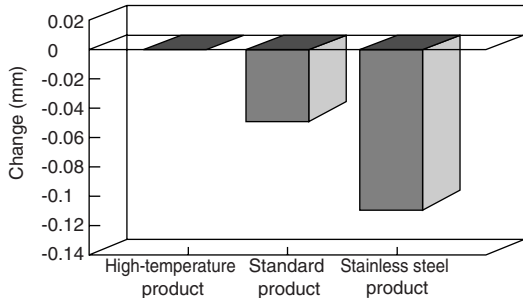

LM rail bend

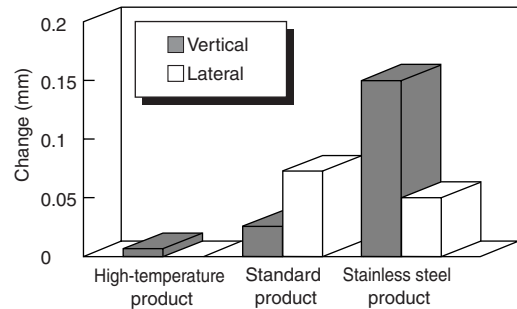

- The overall length and bend data indicate changes that occurred when the samples were heated to 150°C for 100h, then cooled to normal temperature.
- The samples were the high-temperature, standard, and stainless steel models of HSR25+580L.

Greased Ball Rolling Resistance Data

The grease chosen for the new LM Guide provides smoother ball rolling, less subject to changes in rolling resistance and fluctuations (scratchy movement). This property holds good over the entire temperature range, from normal to high.

Mean value

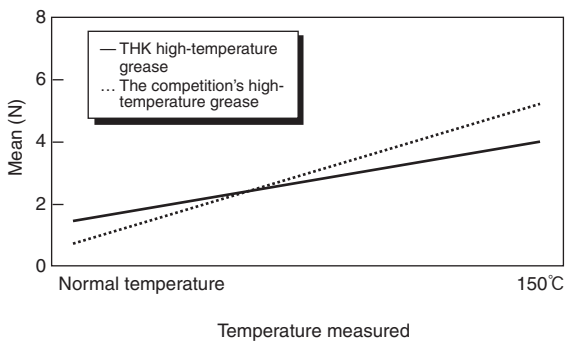

Fluctuation

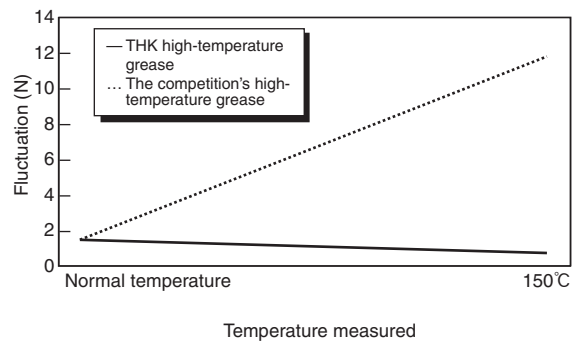

The data above was obtained with HSR25M1R1C1 used as the sample.

Thermal Characteristics of LM Rail and LM Block Materials

- Specific heat capacity : 0.481 J/(g-K)
- Thermal conductivity : 20.67 W/(m-K)
- Mean linear expansion coefficient : $11.8 \times 10^{-6} / ^\circ\text{C}$

Precautions on the Use of the THK High-temperature LM Guide

[Operating Temperature of High-temperature LM Guide]

Permissible up to 150°C.

[Choosing the Right Type of High-temperature LM Guide]

To choose the right type of guide for your application, please refer to Chapter 4, Selecting the Correct Type of LM Guide, in the General Catalog. (The selection procedures are the same as used for the standard LM Guide.) For the temperature coefficient f_T , please refer to graphs presented in the same chapter of the General Catalog. Use 1.0 as the hardness coefficient f_H .

[Dimensional Accuracy of High-temperature LM Guide]

Although the High-temperature LM Guide is built to the same dimensional accuracy as that of the standard LM Guide, yet at high temperatures the accuracy changes by an amount equal to the thermal expansion.

[Calculating the Linear Expansion of the High-temperature LM Guide]

The thermal expansion of High-temperature LM Guide can be calculated from the following equation:

$$L_{2-1} = \alpha (t_2 - t_1) L_1$$

L_{2-1} : thermal expansion due to heating (mm)

α : linear expansion coefficient (see the table below)

t_2 : heating temperature (°C)

t_1 : normal temperature (°C)

L_1 : length at normal temperature (mm)

Table 1 Linear Expansion Coefficients of Various Materials ($\times 10^{-6}/^{\circ}\text{C}$)

(Other values than those of THK High-temperature LM Guide are cited from *Practical Design Part II* (Nikkan Kogyo Shimbun))

	High-temperature LM Guide	SS400	FC25	304 (SUS304)	Aluminum
Linear expansion coefficient	11.8	11.2~11.3	8.6~8.7	16.4	23

Note: Special care must be taken when installing the High-temperature LM Guide on a material with a thermal expansion coefficient which significantly differs from that of the Guide, or where the temperature distribution is not uniform even if the linear expansion coefficients are the same. These conditions can bend the rails and vary the preload on the LM Guide. (For the LM Guide preload, see the General Catalog.)

[Grease Used in High-temperature LM Guide]

Unless otherwise specified, fluorine-based grease is sealed into the High-temperature LM Guide as the standard lubricant. The physical properties of the High-temperature LM Guide grease are as shown below.

(Mixing other greases and lubricating oils can degrade performance. If your application requires use of the Guide under a vacuum, please contact THK.)

Grease name : Crytox GPL225 (DuPont)

Base oil	GPL105
Base oil viscosity (20°C)	550 (cSt)
Oil separation (30 h), 99°C	4% (wt)
Additive	Anticorrosive
Operating temperature range	-35~205°C
Mixing consistency	NLGI No.2

[Changes in Sliding Resistance Due to Grease and Seals]

The LM Guide sliding resistance due to high-temperature grease and seals tends to increase in proportion to the temperature rise.

[Lubrication of High-temperature LM Guide]

Feed grease to the Guide every 100 km of running distance, as a rule. The interval depends on the operating conditions, environment, atmosphere, and temperature. The greasing interval will therefore require adjustment according to the respective case.

LM Guide SR-M1 — High-rigidity Radial Type

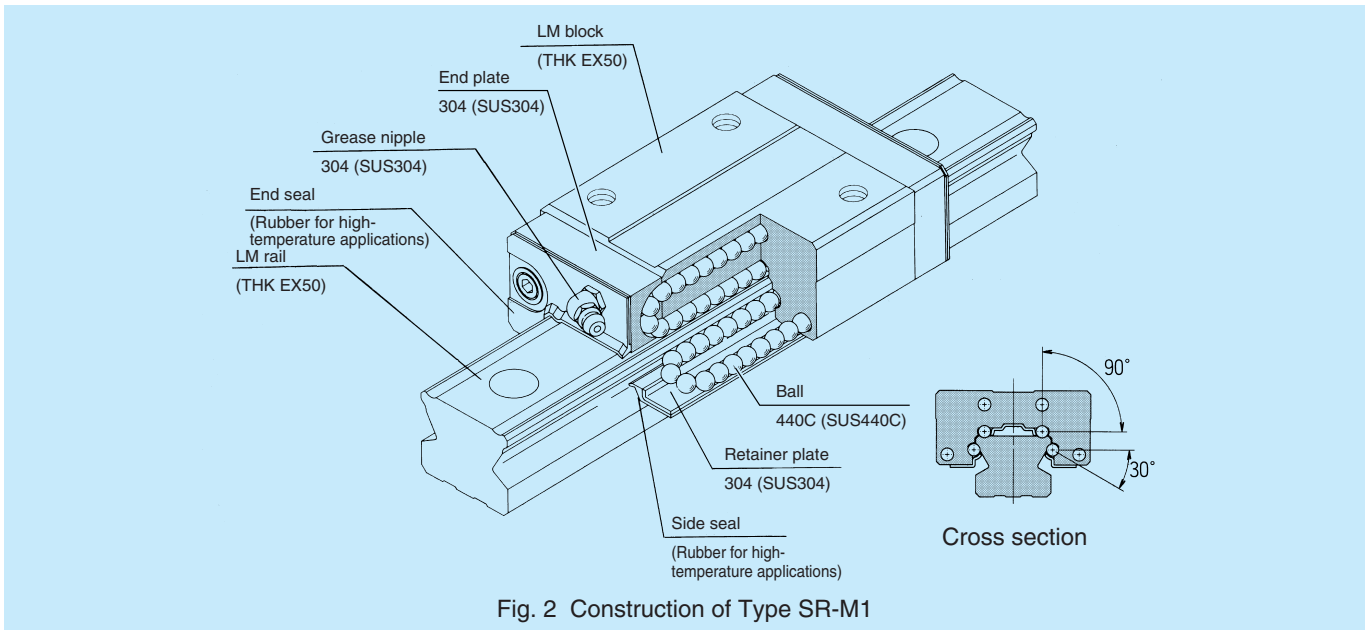

Types and Features

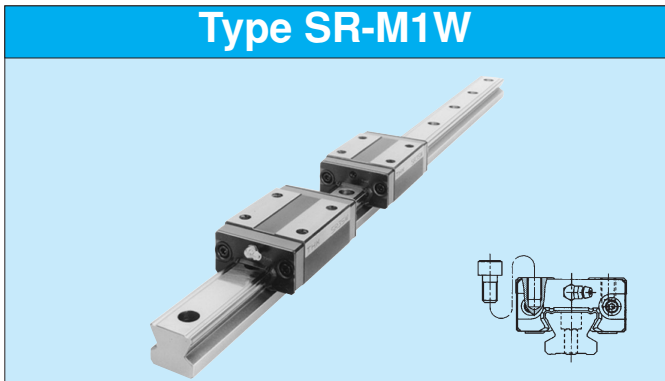

Low-profile, compact, and radial-load durable. One of the representative models of LM Guides.

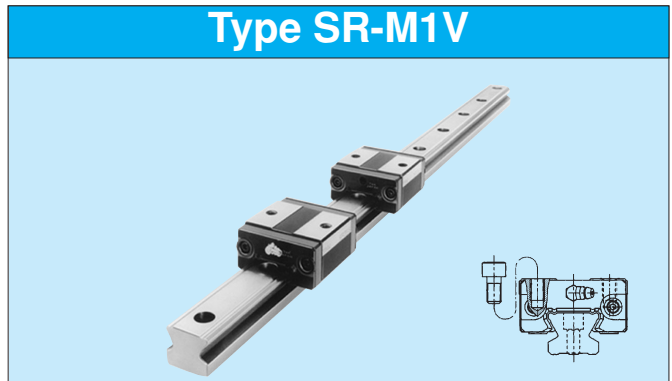

Modified SR-M1W with shortened LM blocks for space savings.

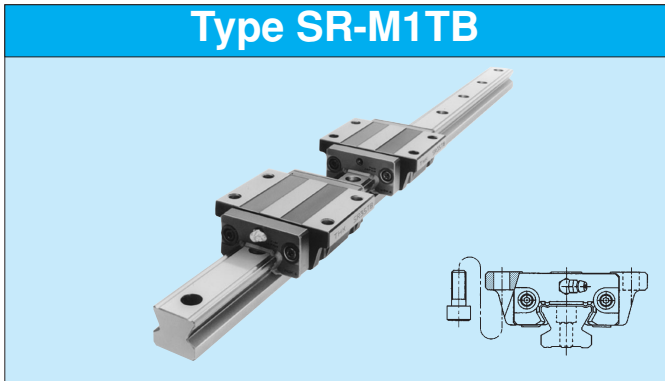

The height is the same as of type SR-M1W. The LM blocks can be attached to a table from below.

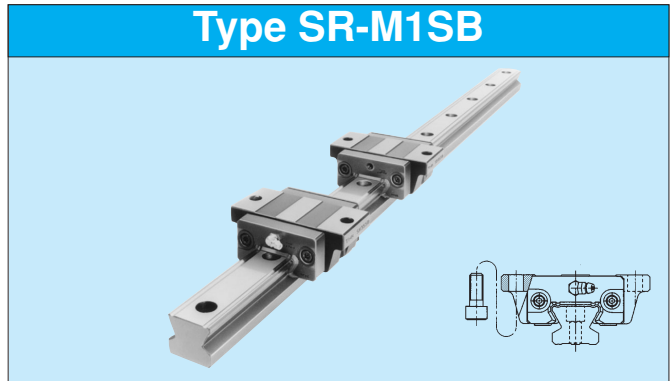

Modified SR-M1TB with shortened LM blocks for space savings.

• Actual product color may differ from the photograph.

LM Guide HSR-M1 — Four-way Equal-Load Type

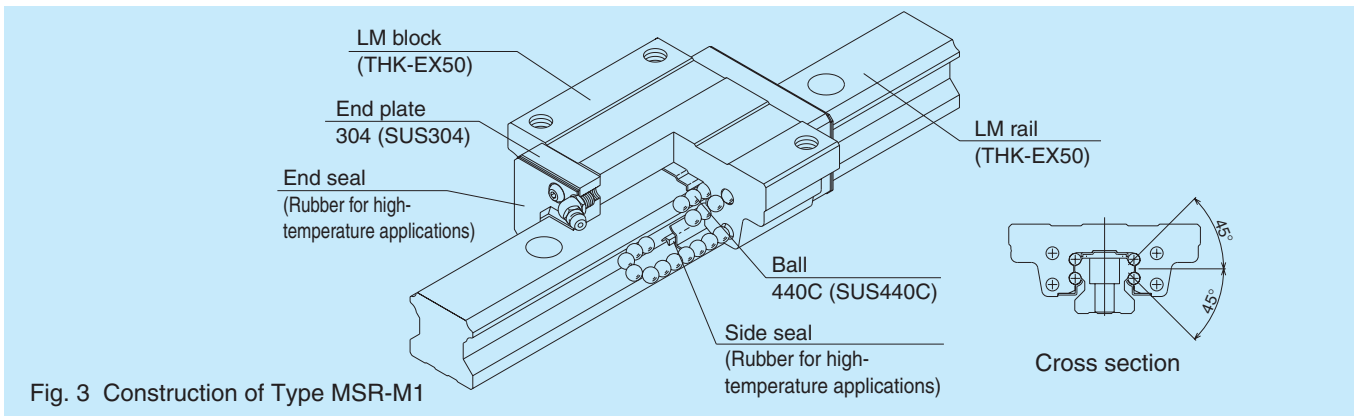
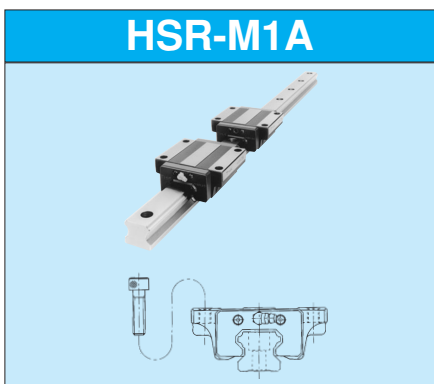

Fig. 3 Construction of Type MSR-M1

Types and Features

Standard heavy duty types



The flange of the LM block is provided with tapped holes for simplified assembly; suitable for build-up systems. Four-bolt type.

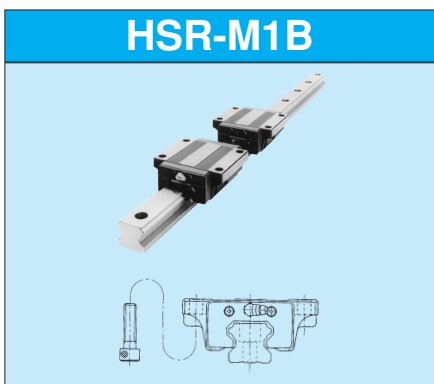

The LM blocks can be attached to a table from below. To be used for a table that does not permit drilling of through holes. Four-bolt type.

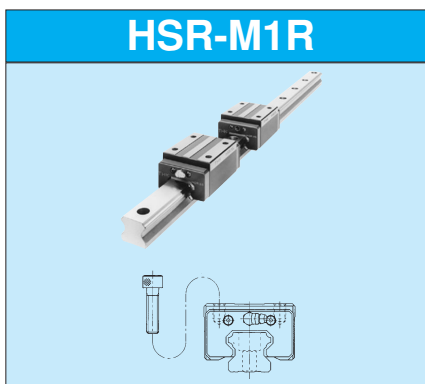

The narrowed flange of the LM block is provided with tapped holes making them convenient for build-up systems. Four-bolt type.

Standard ultra-heavy duty types



While the cross-sectional dimensions are the same as those of the HSR-M1A, the LM block is longer. The number of effective balls is therefore greater than in the HSR-M1A. Four-bolt type.



While the cross-sectional dimensions are the same as those of the HSR-M1B, the LM block is longer. The number of effective balls is therefore greater than in the HSR-M1B. Four-bolt type.



While the cross-sectional dimensions are the same as those of the HSR-M1R, the LM block is longer. The number of effective balls is therefore greater than in the HSR-M1R. Four-bolt type.

• Actual product color may differ from the photograph.

LM Guide HSR — M1YR

Four-way Equal Load, Sideways Installation Type

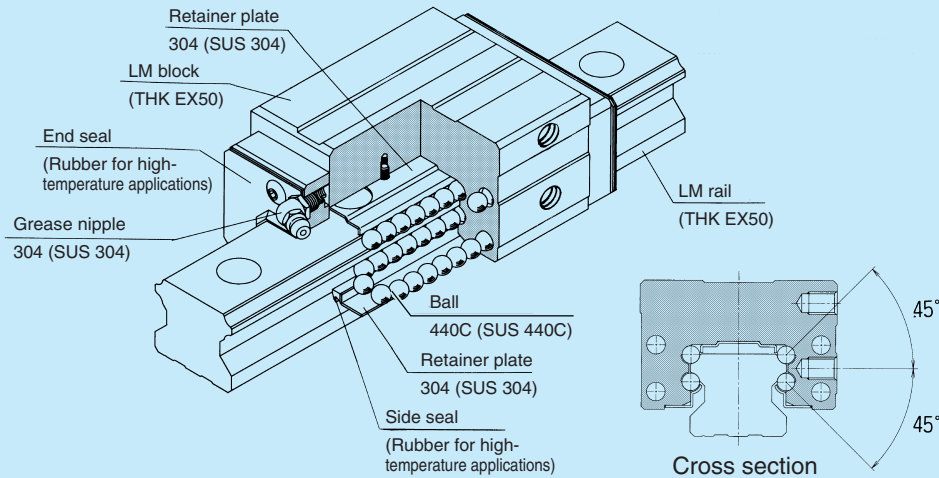

Fig. 4 Construction of Type HSR-M1YR

Simple installation in opposed position

Installing two LM Guides opposing to one another used to pose a number of problems: e.g., it is time-consuming and difficult to attain the required accuracy and to adjust clearance.

In the HSR-M1YR, however, tapped holes provided in the flange of the LM block to aid the mounting of a table has simplified assembly and construction. This contributes to substantial man-hour reduction and improved precision.

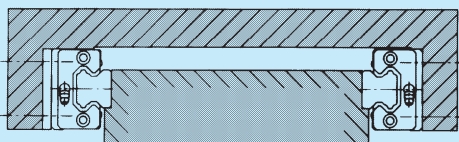

Fig. 5 Conventional Design

Low profile

Sideways installation reduces the mounting height or the spacing between the base and table when the LM Guide is installed. This style of installation is also useful when there is a need for a wide guide to obtain greater table rigidity.

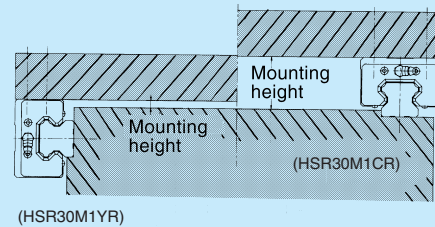

Fig. 7 HSR30YR and CR Installed (for comparison with other installation styles)

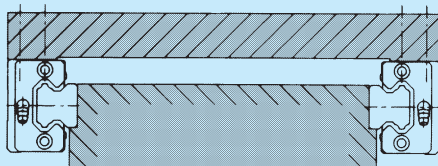

Fig. 6 Type YR Mounting Structure

Higher rigidity achieved against lateral load

HSR-M1YR is installed sideways. This means that the applied load is exerted on the center line of the train of balls, as shown below. Since the load does not act as a moment, a higher rigidity is obtained.

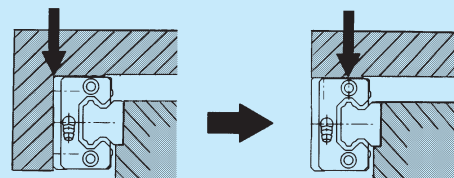
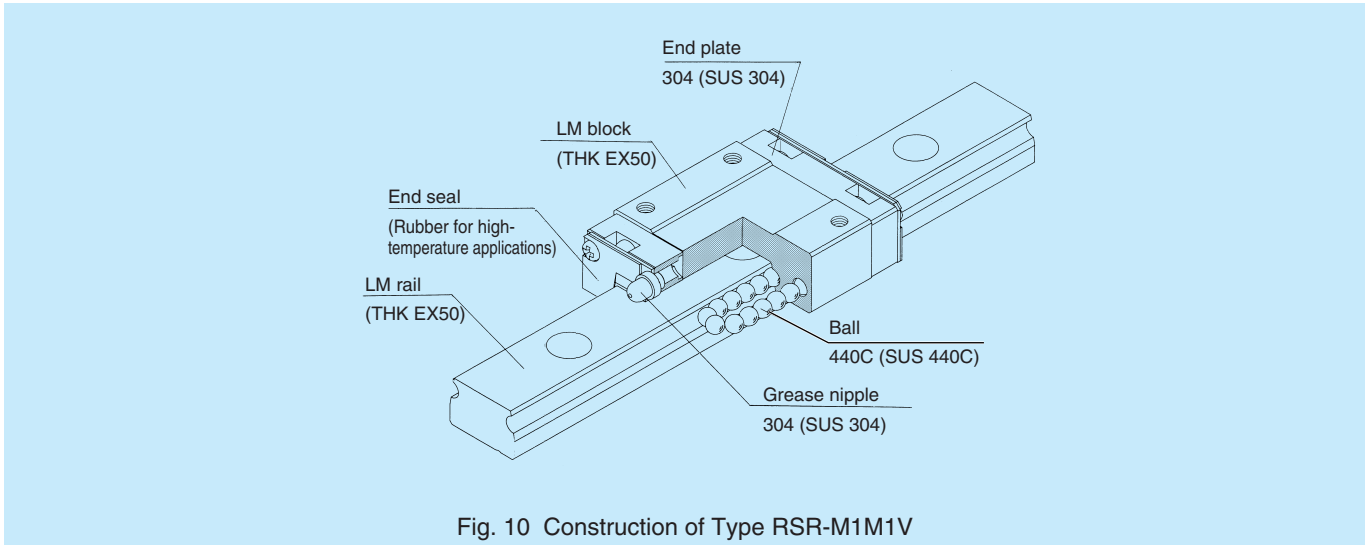

Fig. 8 Conventional Load Focus

Fig. 9 YR Load Focus

Miniature LM Guides RSR-M1 and RSR-M1W



Types and Features



Standard types of Miniature LM Guide.



Modified RSR-M1V with expanded LM block length and width for greater load ratings and permissible moments.



Compared to type RSR-M1V, this type has larger load rating provided by the longer overall length of LM block and increased number of effective balls.



Modified RSR-M1W with increased LM block length, number of effective balls, and load rating. Has the greatest load carrying capability of all Miniature LM Guide models.

• Actual product color may differ from the photograph.

Model Number Coding

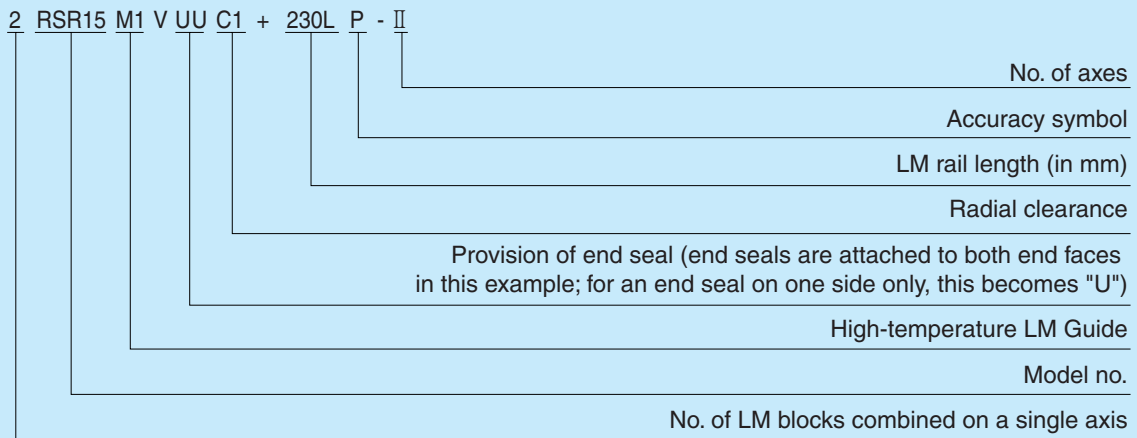
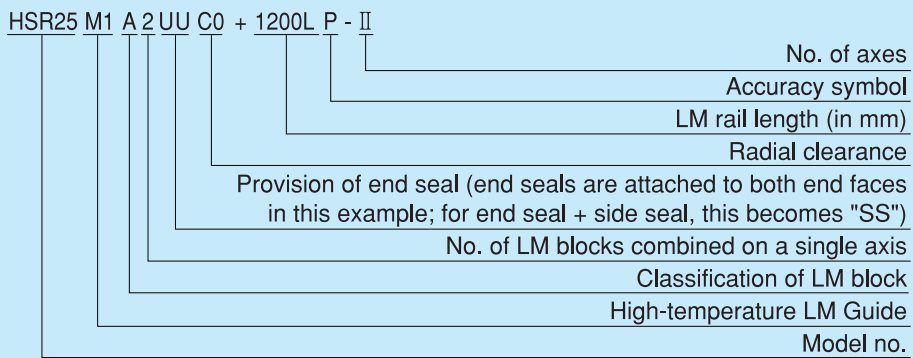
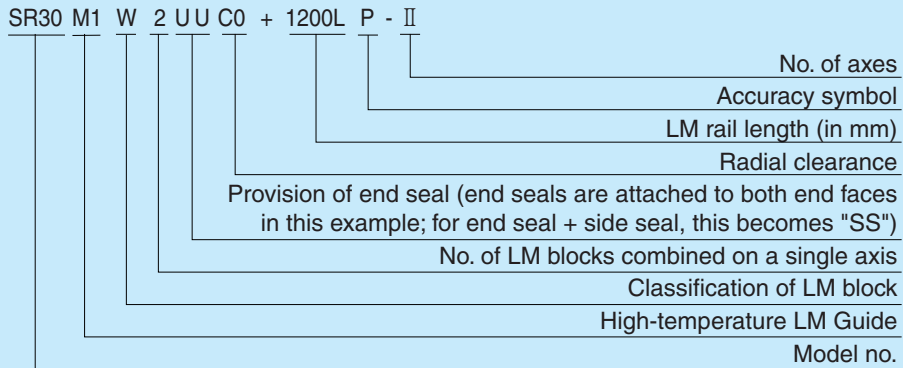

Notes: A model number is allotted to a set comprising a one-axis unit. (A parallel two-axis configuration requires at least two sets.)

Contamination Protection

For the High-Temperature LM Guide, side seals to prevent contaminants from entering the Guide are available from THK.

End seal

A standard accessory.

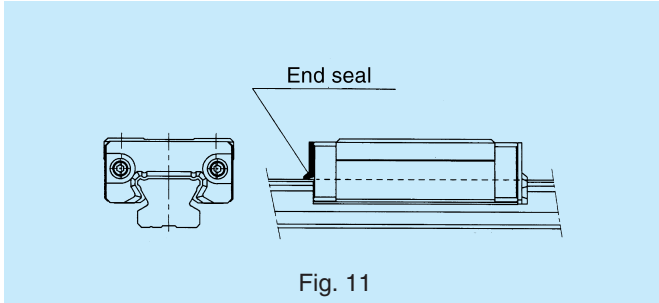

Side seal

Prevents contaminants from entering an LM block from below.

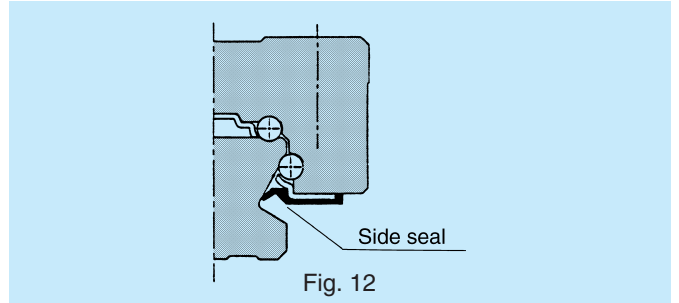

Contamination protection accessory symbol

If a contamination protection accessory is required, please specify this using the symbols shown below. Some models do not accept a contamination protection accessory. Check which parts are applicable, referring to Table 2. Attaching a contamination protection accessory to an LM block changes the block overall length. Add the increment to dimension L provided in the corresponding dimension table.

Table 2

Contamination protection accessory	Symbol
End seal (on both end faces)	UU
End seal + side seal	SS

Table 3

Unit : mm

Model no.	No symbol		U U		S S	
HSR 15M1	○	-8.0	○	—	○	—
HSR 20M1	○	-8.0	○	—	○	—
HSR 25M1	○	-7.8	○	—	○	—
HSR 30M1	○	-7.8	○	—	○	—
HSR 35M1	○	-9.6	○	—	○	—
SR 15M1	○	-5.0	○	—	○	—
SR 20M1	○	-6.3	○	—	○	—
SR 25M1	○	-7.0	○	—	○	—
SR 30M1	○	-7.0	○	—	○	—
SR 35M1	○	-7.0	○	—	○	—
RSR 9M1	○	-3.0	○	—	×	—
RSR 12M1	○	-4.0	○	—	×	—
RSR 15M1	○	-4.0	○	—	×	—
RSR 20M1	○	-5.0	○	—	×	—
RSR 9M1W	○	-3.0	○	—	×	—
RSR 12M1W	○	-3.2	○	—	×	—
RSR 15M1W	○	-4.0	○	—	×	—

Seal resistance

With regard to end seals for the type UU High-Temperature LM Guide, Tables 4 through 6 show the maximum values of seal resistance per LM block with a lubricant applied.

Table 4

Model no.	Seal resistance (N)
SR 15M1	2.5
SR 20M1	3.4
SR 25M1	4.4
SR 30M1	8.8
SR 35M1	11.8

Table 5

Model no.	Seal resistance (N)
HSR 15M1	2.0
HSR 20M1	2.5
HSR 25M1	3.9
HSR 30M1	7.8
HSR 35M1	11.8

Table 6

Model no.	Seal resistance (N)
RSR 9M1	0.1
RSR 12M1	0.4
RSR 15M1	0.8
RSR 20M1	1.0
RSR 9M1W	0.8
RSR 12M1W	1.1
RSR 15M1W	1.3

Notes:

- These seal resistance values are measurements at normal temperature.
- The data for type HSR-M1 apply to type HSR-M1YR as well.

LM Rail Standard and Maximum Lengths

The LM rail standard and maximum lengths of the High-Temperature LM Guide are as shown in Tables 7 through 9. If the maximum length for your application is not within the range found in the tables, we can produce special LM rails intended for connected use.

For dimension G, if you specify a special length, we recommend the values listed in the above tables. A longer dimension G tends to reduce the stability of the rail at the rail ends after installation, possibly reducing accuracy.

For connected use, we produce LM rails with no level difference at the joints. Accordingly, when placing an order, please specify the overall length.



Table 7

Unit: mm

Model no.	SR 15M1	SR 20M1	SR 25M1	SR 30M1	SR 35M1
LM rail standard length (L ₀)	160	220	220	280	280
	220	280	280	360	360
	280	340	340	440	440
	340	400	400	520	520
	400	460	460	600	600
	460	520	520	680	680
	520	580	580	760	760
	580	640	640	840	840
	640	700	700	920	920
	700	760	760	1000	1000
	760	820	820	1080	1080
	820	940	940	1160	1160
	940	1000	1000	1240	1240
	1000	1060	1060	1320	1320
	1060	1120	1120	1400	1400
	1120	1180	1240	1480	1480
1180	1240	1300			
1240	1300	1360			
	1360	1360			
	1420	1420			
		1480			
Standard pitch F	60	60	60	80	80
G	20	20	20	20	20
Max. length	1240	1500	1500	1500	1500

Table 8

Unit: mm

Model no.	HSR 15M1	HSR 20M1	HSR 25M1	HSR 30M1	HSR 35M1
LM rail standard length (L ₀)	160	220	220	280	280
	220	280	280	360	360
	280	340	340	440	440
	340	400	400	520	520
	400	460	460	600	600
	460	520	520	680	680
	520	580	580	760	760
	580	640	640	840	840
	640	700	700	920	920
	700	760	760	1000	1000
	760	820	820	1080	1080
	820	940	940	1160	1160
	940	1000	1000	1240	1240
	1000	1060	1060	1320	1320
	1060	1120	1120	1400	1400
	1120	1180	1180	1480	1480
	1180	1240	1240		
1240	1360	1300			
	1480	1360			
		1420			
		1480			
Standard pitch F	60	60	60	80	80
G	20	20	20	20	20
Max. length	1240	1500	1500	1500	1500

Notes: The data for type HSR-M1 apply to type HSR-M1YR as well.

Table 9

Unit

Model no.	RSR 9M1	RSR 12M1	RSR 15M1	RSR 20M1	RSR 9M1W	RSR 12M1W	RSR 15M1W	
LM rail standard length (L ₀)	55	70	70	220	50	70	110	
	75	95	110	280	80	110	150	
	95	120	150	340	110	150	190	
	115	145	190	460	140	190	230	
	135	170	230	640	170	230	270	
	155	195	270	880	200	270	310	
	175	220	310	1000	260	310	430	
	195	245	350		290	390	550	
	275	270	390		320	470	670	
	375	320	430			550	790	
		370	470					
		470	550					
		570	670					
			870					
	Standard pitch F	20	25	40	60	30	40	40
	G	7.5	10	15	20	10	15	15
	Max. length	1000	1340	1430	1800	1000	1430	1800

Notes: • If connected use is impossible, but you need a rail longer than the maximum lengths in the table, please contact THK.
 • The maximum length varies with the accuracy grade. Regarding the maximum length, please contact THK.

Other Information on the High-Temperature LM Guide

- Permissible load and moment in all four directions
- Radial clearance
- Accuracy standards
- Mounting surface height and fillet profile

For these aspects, see the sections on SR, HSR, HSR-YR, and RSR in the General Catalog.

SR-M1W SR-M1V

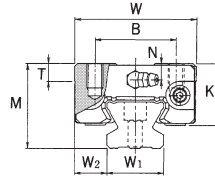

Unit: mm

Model no.	External dimensions			LM block dimensions							
	Height M	Width W	Length L	B	C	S×ℓ	L ₁	T	K	N	E
SR 15 M1W SR 15 M1V	24	34	57 41	26	26	M4×7	39.5 22.9	6	19.5	6	5.5
SR 20 M1W SR 20 M1V	28	42	66.5 48	32	32	M5×8	46.7 27.8	7.5	22	6	12
SR 25 M1W SR 25 M1V	33	48	83 60	35	35	M6×9	59 35.2	8	26	7	12
SR 30 M1W SR 30 M1V	42	60	97 68	40	40	M8×12	69.3 40.4	9	32.5	8	12
SR 35 M1W SR 35 M1V	48	70	111 78	50	50	M8×12	79 45.7	13	36.5	8.5	12

SR-M1TB SR-M1SB

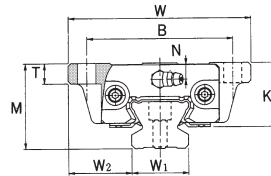

Unit: mm

Model no.	External dimensions			LM block dimensions							
	Height M	Width W	Length L	B	C	S	L ₁	T	K	N	E
SR 15 M1TB SR 15 M1SB	24	52	57 41	41	26	4.5	39.5 22.9	7	19.5	6	5.5
SR 20 M1TB SR 20 M1SB	28	59	66.5 48	49	32	5.5	46.7 27.8	9	22	6	12
SR 25 M1TB SR 25 M1SB	33	73	83 60	60	35	7	59 35.2	10	26	7	12
SR 30 M1TB SR 30 M1SB	42	90	97 68	72	40	9	69.3 40.4	10	32.5	8	12
SR 35 M1TB SR 35 M1SB	48	100	111 78	82	50	9	79 45.7	13	36.5	8.5	12

• For the load rating in the respective direction, see the pages on type SR in the General Catalog.

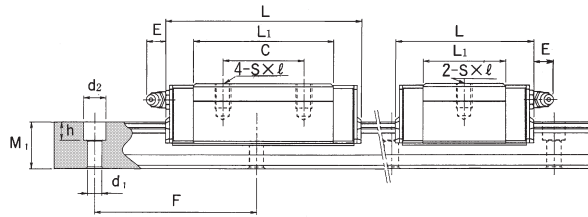

SR-M1W (heavy-duty type) SR-M1V (intermediate-duty type) Unit: mm

Grease nipple	LM rail dimensions					Basic load rating		Mass	
	Width W_1 ± 0.05	W_2	Height M_1	Pitch F	$d_1 \times d_2 \times h$	C kN	C_0 kN	LM block kg	LM rail kg/m
PB1021B	15	9.5	12.5	60	3.5×6×4.5	9.51 5.39	19.3 11.1	0.2 0.12	1.2
B-M6F	20	11	15.5	60	6×9.5×8.5	12.5 7.16	25.2 14.4	0.3 0.2	2.1
B-M6F	23	12.5	18	60	7×11×9	20.3 11.7	39.5 22.5	0.4 0.3	2.7
B-M6F	28	16	23	80	7×11×9	30 17.2	56.8 32.5	0.8 0.5	4.3
B-M6F	34	18	27.5	80	9×14×12	41.7 23.8	77.2 44.1	1.2 0.8	6.4

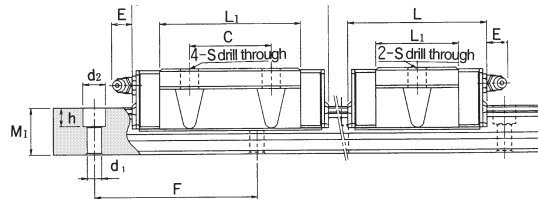

SR-M1TB (heavy-duty type) SR-M1SB (intermediate-duty type) Unit: mm

Grease nipple	LM rail dimensions					Basic load rating		Mass	
	Width W_1 ± 0.05	W_2	Height M_1	Pitch F	$d_1 \times d_2 \times h$	C kN	C_0 kN	LM block kg	LM rail kg/m
PB1021B	15	18.5	12.5	60	3.5×6×4.5	9.51 5.39	19.3 11.1	0.2 0.15	1.2
B-M6F	20	19.5	15.5	60	6×9.5×8.5	12.5 7.16	25.2 14.4	0.4 0.3	2.1
B-M6F	23	25	18	60	7×11×9	20.3 11.7	39.5 22.5	0.6 0.4	2.7
B-M6F	28	31	23	80	7×11×9	30 17.2	56.8 32.5	1.1 0.8	4.3
B-M6F	34	33	27.5	80	9×14×12	41.7 23.8	77.2 44.1	1.5 1.0	6.4

- For the LM rail standard length, see page 11.
- For the model number coding, see page 9.

1kN ≒ 102kgf

HSR-M1A

HSR-M1LA

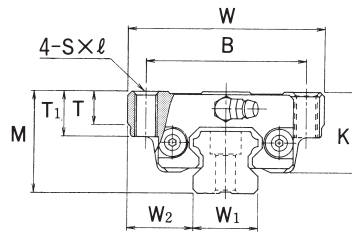

Model no.	External dimensions			LM block dimensions								
	Height M	Width W	Length L	B	C	S×ℓ	L ₁	T	T ₁	K	N	E
HSR 15 M1A	24	47	59.6	38	30	M5×0.8×11	38.8	7	11	19.3	4.3	5.5
HSR 20 M1A	30	63	76	53	40	M6×10	50.8	10	10	26	5	12
HSR 20 M1LA	30	63	92	53	40	M6×10	66.8	10	10	26	5	12
HSR 25 M1A	36	70	83.9	57	45	M8×16	59.5	10	16	30.5	6	12
HSR 25 M1LA	36	70	103	57	45	M8×16	78.6	10	16	30.5	6	12
HSR 30 M1A	42	90	98.8	72	52	M10×18	70.4	10	18	35	7	12
HSR 30 M1LA	42	90	121.4	72	52	M10×18	93	10	18	35	7	12
HSR 35 M1A	48	100	112	82	62	M10×21	80.4	13	21	40.5	8	12
HSR 35 M1LA	48	100	137.4	82	62	M10×21	105.8	13	21	40.5	8	12

• In high-temperature type HSR, length L is longer than in normal type HSR (L₁ is the same).

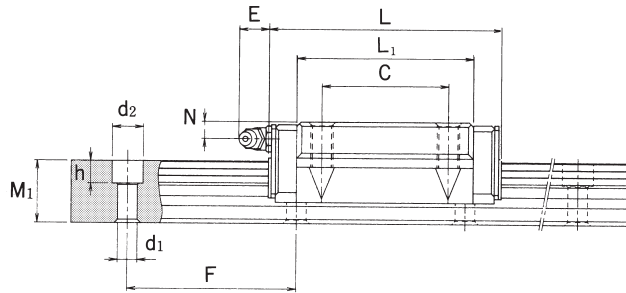

Unit: mm

Grease nipple	LM rail dimensions					Basic load rating		Mass	
	Width W_1 ± 0.05	W_2	Height M_1	Pitch F	$d_1 \times d_2 \times h$	C kN	C_0 kN	LM block kg	LM rail kg/m
PB1021B	15	16	15	60	4.5×7.5×5.3	8.33	13.5	0.2	1.5
B-M6F	20	21.5	18	60	6×9.5×8.5	13.8	23.8	0.35	2.3
B-M6F	20	21.5	18	60	6×9.5×8.5	21.3	31.8	0.47	2.3
B-M6F	23	23.5	22	60	7×11×9	19.9	34.4	0.59	3.3
B-M6F	23	23.5	22	60	7×11×9	27.2	45.9	0.75	3.3
B-M6F	28	31	26	80	9×14×12	28	46.8	1.1	4.8
B-M6F	28	31	26	80	9×14×12	37.3	62.5	1.3	4.8
B-M6F	34	33	29	80	9×14×12	37.3	61.1	1.6	6.6
B-M6F	34	33	29	80	9×14×12	50.2	81.5	2.0	6.6

- For the LM rail standard length, see page 12.
- For the model number coding, see page 9.

1kN ≙ 102kgf

HSR-M1B

HSR-M1LB

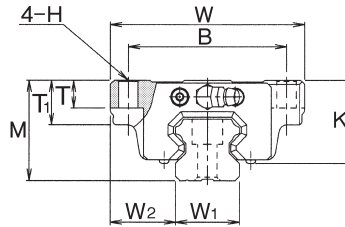

Model no.	External dimensions			LM block dimensions								
	Height M	Width W	Length L	B	C	H	L ₁	T	T ₁	K	N	E
HSR 15 M1B	24	47	59.6	38	30	4.5	38.8	7	11	19.3	4.3	5.5
HSR 20 M1B	30	63	76	53	40	6	50.8	10	10	26	5	12
HSR 20 M1LB	30	63	92	53	40	6	66.8	10	10	26	5	12
HSR 25 M1B	36	70	83.9	57	45	7	59.5	10	16	30.5	6	12
HSR 25 M1LB	36	70	103	57	45	7	78.6	10	16	30.5	6	12
HSR 30 M1B	42	90	98.8	72	52	9	70.4	10	18	35	7	12
HSR 30 M1LB	42	90	121.4	72	52	9	93	10	18	35	7	12
HSR 35 M1B	48	100	112	82	62	9	80.4	13	21	40.5	8	12
HSR 35 M1LB	48	100	137.4	82	62	9	105.8	13	21	40.5	8	12

• In high-temperature type HSR, length L is longer than in normal type HSR (L₁ is the same).

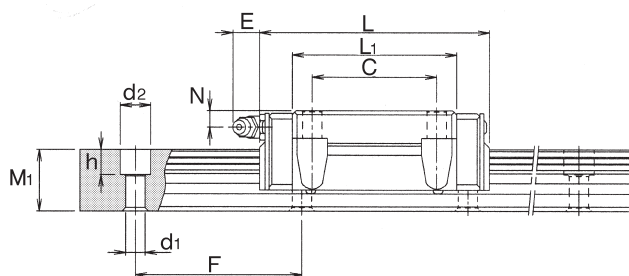

Unit: mm

Grease nipple	LM rail dimensions					Basic load rating		Mass	
	Width W_1 ± 0.05	W_2	Height M_1	Pitch F	$d_1 \times d_2 \times h$	C kN	C_0 kN	LM block kg	LM rail kg/m
PB1021B	15	16	15	60	4.5×7.5×5.3	8.33	13.5	0.2	1.5
B-M6F	20	21.5	18	60	6×9.5×8.5	13.8	23.8	0.35	2.3
B-M6F	20	21.5	18	60	6×9.5×8.5	21.3	31.8	0.47	2.3
B-M6F	23	23.5	22	60	7×11×9	19.9	34.4	0.59	3.3
B-M6F	23	23.5	22	60	7×11×9	27.2	45.9	0.75	3.3
B-M6F	28	31	26	80	9×14×12	28	46.8	1.1	4.8
B-M6F	28	31	26	80	9×14×12	37.3	62.5	1.3	4.8
B-M6F	34	33	29	80	9×14×12	37.3	61.1	1.6	6.6
B-M6F	34	33	29	80	9×14×12	50.2	81.5	2.0	6.6

- For the LM rail standard length, see page 12.
- For the model number coding, see page 9.

1kN ≙ 102kgf

HSR-M1R

HSR-M1LR

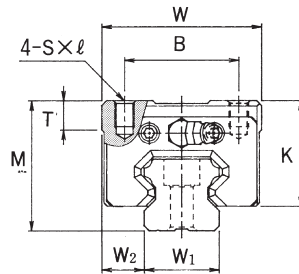

Model no.	External dimensions			LM block dimensions							
	Height M	Width W	Length L	B	C	S×l	L ₁	T	K	N	E
HSR 15 M1R	28	34	59.6	26	26	M4×0.7×5	38.8	6	23.3	8.3	5.5
HSR 20 M1R	30	44	76	32	36	M5×0.8×6	50.8	8	26	5	12
HSR 20 M1LR	30	44	92	32	50	M5×0.8×6	66.8	8	26	5	12
HSR 25 M1R	40	48	83.9	35	35	M6×8	59.5	8	34.5	10	12
HSR 25 M1LR	40	48	103	35	50	M6×8	78.6	8	34.5	10	12
HSR 30 M1R	45	60	98.8	40	40	M8×10	70.4	8	38	10	12
HSR 30 M1LR	45	60	121.4	40	60	M8×10	93	8	38	10	12
HSR 35 M1R	55	70	112	50	50	M8×12	80.4	10	47.5	15	12
HSR 35 M1LR	55	70	137.4	50	72	M8×12	105.8	10	47.5	15	12

• In high-temperature type HSR, length L is longer than in normal type HSR (L₁ is the same).

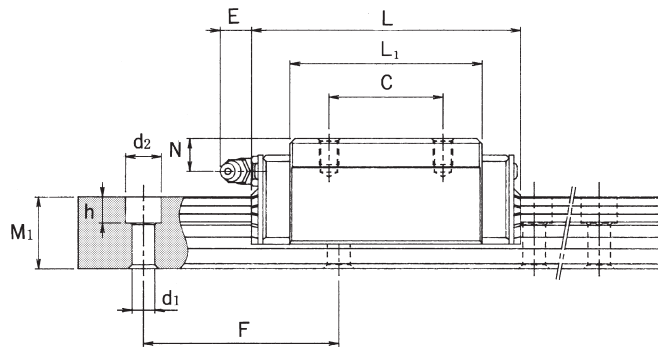

Unit: mm

Grease nipple	LM rail dimensions					Basic load rating		Mass	
	Width W_1 ± 0.05	W_2	Height M_1	Pitch F	$d_1 \times d_2 \times h$	C kN	C_0 kN	LM block kg	LM rail kg/m
PB1021B	15	9.5	15	60	4.5×7.5×5.3	8.33	13.5	0.18	1.5
B – M6F	20	12	18	60	6×9.5×8.5	13.8	23.8	0.25	2.3
B – M6F	20	12	18	60	6×9.5×8.5	21.3	31.8	0.35	2.3
B – M6F	23	12.5	22	60	7×11×9	19.9	34.4	0.54	3.3
B – M6F	23	12.5	22	60	7×11×9	27.2	45.9	0.67	3.3
B – M6F	28	16	26	80	9×14×12	28	46.8	0.9	4.8
B – M6F	28	16	26	80	9×14×12	37.3	62.5	1.1	4.8
B – M6F	34	18	29	80	9×14×12	37.3	61.1	1.5	6.6
B – M6F	34	18	29	80	9×14×12	50.2	81.5	2.0	6.6

- For the LM rail standard length, see page 12.
- For the model number coding, see page 9.

1kN ≙ 102kgf

HSR-M1YR

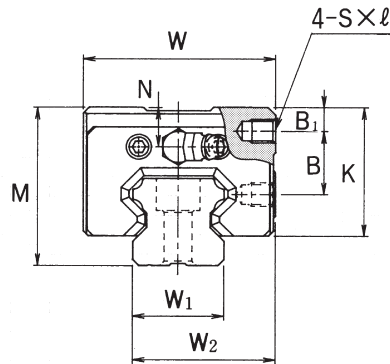

Unit: mm

Model no.	External dimensions			LM block dimensions							
	Height M	Width W	Length L	B ₁	B	C	S × l	L ₁	K	N	E
HSR 15M1YR	28	33.5	59.6	4.3	11.5	18	M4×0.7×5	38.8	23.3	8.3	5.5
HSR 20M1YR	30	43.5	76	4	11.5	25	M5×0.8×6	50.8	26	5	12
HSR 25M1YR	40	47.5	83.9	6	16	30	M6×6	59.5	34.5	10	12
HSR 30M1YR	45	59.5	98.8	8	16	40	M6×9	70.4	38	10	12
HSR 35M1YR	55	69.5	112	8	23	43	M8×10	80.4	47	15	12

- In high-temperature type HSR, length L is longer than in normal type HSR (L₁ is the same).

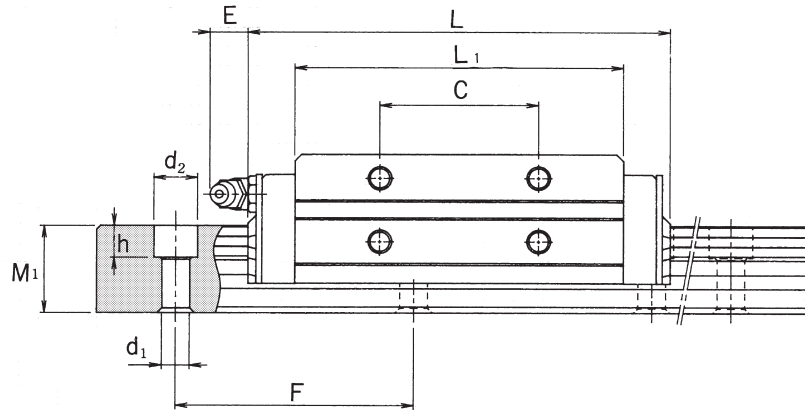

Unit: mm

Grease nipple	LM rail dimensions					Basic load rating		Mass	
	Width W_1 ± 0.05	W_2	Height M_1	Pitch F	$d_1 \times d_2 \times h$	C kN	C_0 kN	LM block kg	LM rail kg/m
PB1021B	15	24	15	60	4.5×7.5×5.3	8.33	13.5	0.18	1.5
B – M6F	20	31.5	18	60	6×9.5×8.5	13.8	23.8	0.25	2.3
B – M6F	23	35	22	60	7×11×9	19.9	34.4	0.54	3.3
B – M6F	28	43.5	26	80	9×14×12	28	46.8	0.9	4.8
B – M6F	34	51.5	29	80	9×14×12	37.3	61.1	1.5	6.6

• For the LM rail standard length, see “LM Rail Standard and Maximum Lengths” for type HSR-M1 on page 12.

RSR-M1V/RSR-M1N

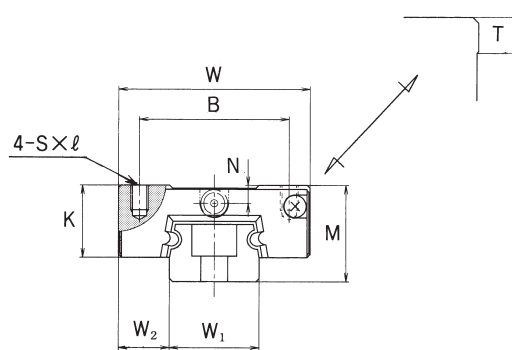

Unit: mm

Model no.	External dimensions			LM block dimensions									Grease nipple (Oil hole)
	Height M	Width W	Length L	B	C	S×l	L ₁	T	K	N	E		
RSR 9 M1K RSR 9 M1N	10	20	31 41	15	10 16	M3×3.0	19.8 29.8	–	7.8	–	–	–	
RSR 12 M1V RSR 12 M1N	13	27	35 47.5	20	15 20	M3×3.5	20.6 33.3	–	10	3	–	∅ 2 drilled hole	
RSR 15 M1V RSR 15 M1N	16	32	43 61	25	20 25	M3×4	25.7 43.5	–	12	3	3.6 3	PB107	
RSR 20 M1V RSR 20 M1N	25	46	66.5 86.5	38	38 38	M4×6	45.2 65	6	17.5	5	6.4	A-M6F	

- Notes:
- For the model number coding, see page 9.
 - For the load rating in the respective direction, see the pages on type RSR in the General Catalog.

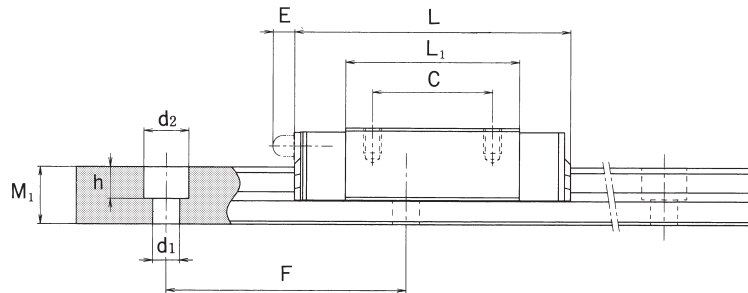

Unit: mm

LM rail dimensions					Basic load rating		Mass	
W_1	W_2	M_1	F	$d_1 \times d_2 \times h$	C N	C_0 N	LM block kg	LM rail kg/m
9 ⁰ _{-0.02}	5.5	5.5	20	3.5×6×3.3	1470 2600	2250 3960	0.018 0.027	0.32
12 ⁰ _{-0.025}	7.5	7.5	25	3.5×6×4.5	2650 4300	4020 6650	0.037 0.055	0.58
15 ⁰ _{-0.025}	8.5	9.5	40	3.5×6×4.5	4410 7160	6570 10700	0.069 0.093	0.925
20 ⁰ _{-0.03}	13	15	60	6×9.5×8.5	8820 14200	12700 20600	0.245 0.337	1.95

- For permissible moments M_A , M_B , and M_C , see the section on type RSR in the General Catalog.
- For the LM rail standard length, see page 12.

RSR-M1W (WV) /RSR-M1WN

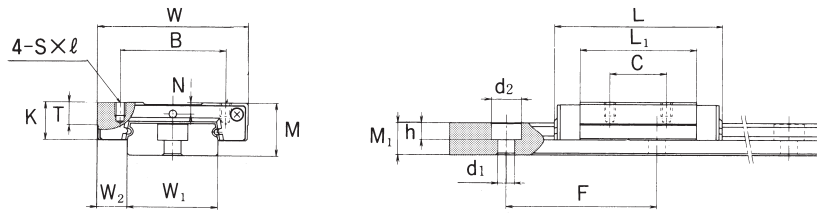

RSR9M1WV, 9M1WN
RSR12M1WV, 12M1WN

Unit: mm

Model no.	External dimensions			LM block dimensions									Grease nipple (Oil hole)
	Height M	Width W	Length L	B	C	S×ℓ	L ₁	T	K	N	E		
RSR 9 M1K RSR 9 M1WN	12	30	39 51	21 23	12 24	M2.6×3 M3×3	27 38.7	-	7.8	2	-	ø 1.6 drilled hole	
RSR 9 M1K RSR 12 M1WN	14	40	44.5 59.5	28 28	15 28	M3×3.5	30.9 45.9	6	10	3	-	ø 2 drilled hole	
RSR 15 M1WV RSR 15 M1WN	16	60	55.5 74.5	45 45	20 35	M4×4.5	38.9 57.9	6	12	3.5	3	PB 107	

- Notes:
- For the model number coding, see page 9.
 - For the load rating in the respective direction, see the pages on type RSR in the General Catalog.
 - For permissible moments M_A , M_B , and M_C , see the section on type RSR in the General Catalog.

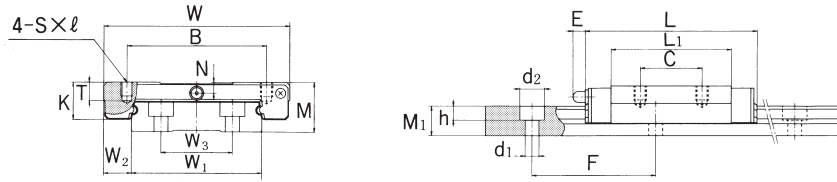

RSR15M1WV, 15M1WN

Unit: mm

LM rail dimensions						Basic load rating		Mass	
W_1	W_2	W_3	M_1	F	$d_1 \times d_2 \times h$	C N	C_0 N	LM block kg	LM rail kg/m
$18 \begin{smallmatrix} 0 \\ -0.05 \end{smallmatrix}$	6	—	7.5	30	$3.5 \times 6 \times 4.5$	2450 3520	3920 5370	0.035 0.051	1.08
$24 \begin{smallmatrix} 0 \\ -0.05 \end{smallmatrix}$	8	—	8.5	40	$4.5 \times 8 \times 4.5$	4020 5960	6080 9210	0.075 0.101	1.5
$42 \begin{smallmatrix} 0 \\ -0.05 \end{smallmatrix}$	9	23	9.5	40	$4.5 \times 8 \times 4.5$	6660 9910	9800 14900	0.17 0.210	3.0

• For the LM rail standard length, see page 12.

THK High-Temperature LM Guide Series

Precautions on Use

Handling

- Do not drop the product or subject it to impact, as doing so may damage it. Exercise due care in handling the product.
- Unauthorized disassembling of the product can result in the entry of foreign matter and reduce precision. Therefore, disassembly should not be performed unless absolutely necessary.
- Tilting an LM rail can dislocate the LM block, possibly causing it to fall. Exercise due care to prevent the LM block detaching.
- The product is moisture proof packed after sufficiently degreased and washed. Please open the package just before use.
- After unpacking the LM Guide, store it in a clean, dry container with a desiccant. Do not apply corrosion-preventive oil, volatile corrosion-preventive paper (agent), or the like.
- Handle the product in a clean place, wearing vinyl gloves.

Operating temperature range

- Although the maximum permissible temperature for the product is 150°C, consider an appropriate temperature and a hardness coefficient (the latter = 1) when calculating nominal service life and static safety factor. For details, see this catalog and the General Catalog.

* LM Guide is a trademark of THK Co., Ltd.

* Product appearance, specifications, and the like are subject to change without prior notice for purposes of improvement. Before using a product for the first time, contact THK.

Unauthorized reproduction prohibited.

THK THK CO., LTD.

HEAD OFFICE 3-11-6, NISHI-GOTANDA, SHINAGAWA-KU, TOKYO 141-8503 JAPAN
INTERNATIONAL SALES DEPARTMENT PHONE:(03)5434-0351 FAX:(03)5434-0353

U. S. A.

CHICAGO
PHONE:(847)310-1111 FAX:(847)310-1182

NEW JERSEY

PHONE:(201)529-1950 FAX:(201)529-1962

LOS ANGELES

PHONE:(714)891-6752 FAX:(714)894-9315

SAN FRANCISCO

PHONE:(925)455-8948 FAX:(925)455-8965

ATLANTA

PHONE:(770)840-7990 FAX:(770)840-7897

DETROIT

PHONE:(248)594-7552 FAX:(248)594-7558

BOSTON

PHONE:(781)575-1151 FAX:(781)575-9295

INDIANAPOLIS

PHONE:(317)543-9501 FAX:(317)543-9604

MINNEAPOLIS

PHONE:(612)953-4442 FAX:(612)953-4441

CANADA (MISSISSAUGA, ONT)

PHONE:(905)712-2922 FAX:(905)712-2925

BRASIL (SÃO PAULO)

PHONE:(011)3857-9911 FAX:(011)3857-9900

GERMANY

DÜSSELDORF

PHONE:(02102)74250 FAX:(02102)7425299

STUTTGART

PHONE:(07141)2757-0 FAX:(07141)2757-90

U.K. (MILTON KEYNES)

PHONE:(01908)222159 FAX:(01908)222161

FRANCE (LYON)

PHONE:(0437)49.14.00 FAX:(0437)49.14.01

ITALY (MILAN)

PHONE:(039)2842079 FAX:(039)2842527

SWEDEN (JÄRFÄLLA)

PHONE:(08)4457630 FAX:(08)4457639

AUSTRIA (PASCHING)

PHONE:(07229)51400 FAX:(07229)51400-79

PGM BALLSCREWS LIMITED (COVENTRY)

PHONE:(01203)841900 FAX:(01203)611032

PGM BALLSCREWS IRELAND LIMITED (DUBLIN)

PHONE:(01)4513922 FAX:(01)4513469

TAIWAN

TAIPEI

PHONE:(02)2585-8554 FAX:(02)2585-8495

TAICHUNG

PHONE:(04)359-1505 FAX:(04)359-1506

CHINA

BEIJING

PHONE:(10)6590-3557 FAX:(10)6590-3557

HONG KONG

PHONE:23761091, 23761252 FAX:23760749

MALAYSIA (KUALA LUMPUR)

PHONE:(03)987-1137 FAX:(03)987-8071

INDIA (BANGALORE)

PHONE:(080)330-1524 FAX:(080)330-1524

KOREA (SEOUL)

PHONE:(02)3463-0351 FAX:(02)3017-0351

