

Linear Stage

Table of Contents

1. Features	1
2. Description of Serial Number	1
3. Max. Speed Limit	2
4. Specifications	3
5. Accuracy Grade	4
6. Motor and motor adaptor flange	4
6-1 Motor and motor adaptor flange	4
6-2 Motor Adaptor Flange	5
7. Optional function	7
7-1 Bellows	7
7-2 Switch	7
8. Life	8
8-1 Guideway	8
8-2 Ballscrew and Bearing	8
9. Lubrication	8
10. Dimension	9
10-1 Without Cover	9
10-2 With Cover	12

(The specifications in this catalogue are subject to change without notification.)

Linear Stage



KK Type

The Linear Stage KK is a slider actuated by a motor-driven ballscrew and guided by a linear guideway with a U-shape rail. The slider acts as the ballscrew's nut and the guideway's block.

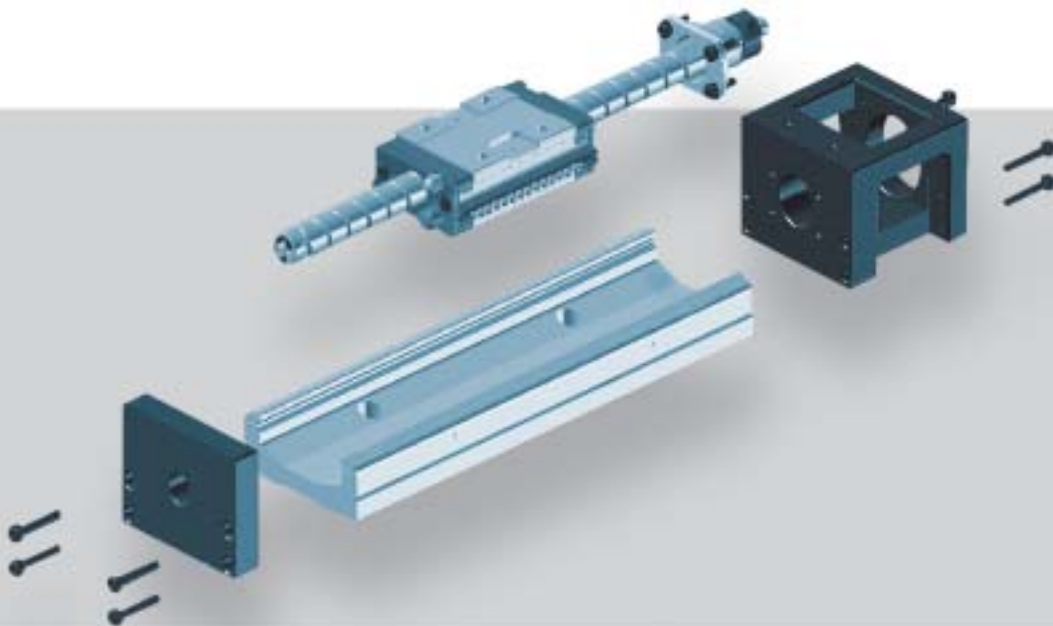

1.Features

- (1) Easy for system design, installation and maintenance
- (2) Compact and light weight
- (3) High accuracy
- (4) High stiffness
- (5) Capable of Well equipped with Necessary Accessories as Required

The structure is designed for high stiffness and light weigh. The FEM analysis is shown as follows:

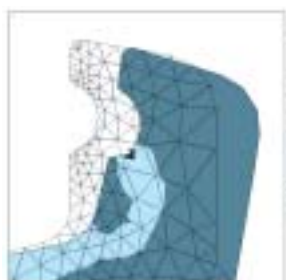

Figure 1



Figure 2

2. Description of Serial Number

Example : KK6010P-400EA2E-F0CS0

KK	60	10	P	E	-	400	E	A	2	E	-	F0	C	S	0
KK Stage Nominal Width : 40, 50, 60, 86, 100 Ballscrew Lead Width KK 40 : 1 KK 50 : 2 KK 60 : 5, 10 KK 86 : 10, 20 KK 100 : 20 Accuracy Grade : P - Precision C - Normal E : Ballscrew Special order; None : normal type Rail Length (unit : mm) KK40 : 100, 150, 200 KK50 : 150, 200, 250, 300 KK60 : 150,200,300, 400, 500, 600 KK86 : 340, 440, 540, 640, 740, 940 KK100 : 980, 1080, 1180, 1280, 1380 E: Rail Special order ; None : normal type															
															Switch type: 0 : only switch rail 1 : Omron SX671 2 : Omron SX674 3 : SUNX GL-12F 4 : SUNX GL-N12F-PX10 S : Including Switch ; None : No C : Cover type ; B : Bellows None : Normal type Motor Adaptor Flange ref. catalog E: Block Special order ; None : normal type Number of Block : 1 or 2 Block Type : A – Normal ; S - Short

3. Max. Speed Limit

Model	Ball screw Lead (mm)	Rail Length (mm)	Speed (mm/sec)	
			Precision	Normal
KK40	01	100	190	-
		150	190	-
		200	190	-
KK50	02	150	270	-
		200	270	-
		250	270	-
		300	270	-
KK60	05	150	550	390
		200	550	390
		300	550	390
		400	550	390
		500	550	390
		600	340	340
	10	150	1100	790
		200	1100	790
		300	1100	790
		400	1100	790
		500	1100	790
		600	670	670
KK86	10	340	740	520
		440	740	520
		540	740	520
		640	740	520
		740	740	520
		940	-	430
	20	340	1480	1050
		440	1480	1050
		540	1480	1050
		640	1480	1050
		740	1480	1050
		940	-	870
KK100	20	980	1120	-
		1080	980	-
		1180	750	-
		1280	-	-
		1380	-	-

4. Specifications

		KK4001	KK5002	KK6005		KK6010		KK8610		KK8620		KK10020		
		Precision	Precision	Precision	Normal	Precision	Normal	Precision	Normal	Precision	Normal	Precision	Normal	
Ball screw	Nominal Diameter (mm)	8		12				15				20		
	Lead (mm)	1	2	5		10		10		20		20		
	Basic Dynamic Load Rating (N)	735	2136	3744	3377	2410	2107	7144	6429	4645	4175	7046	4782	
	Basic Static Load Rating (N)	1538	3489	6243	5625	3743	3234	12642	11387	7655	6889	12544	9163	
Guideway	Basic Dynamic Load Rating (N)	Block A	3920	8007	13230				31458				39200	
		Block S	-	-	7173				-				-	
	Basic Static Load Rating (N)	Block A	6468	12916	21462				50764				63406	
		Block S	-	-	11574				-				-	
	Allowable Static Moment M_x (pitching) (N-m)	Block A1	33	116	152				622				960	
		Block A2	182	278	348				3050				4763	
		Block S1	-	-	72				-				-	
		Block S2	-	-	205				-				-	
	Allowable Static Moment M_y (yawing) (N-m)	Block A1	33	116	152				622				960	
		Block A2	182	278	348				3050				4763	
		Block S1	-	-	72				-				-	
		Block S2	-	-	205				-				-	
Allowable Static Moment M_o (rolling) (N-m)	Block A1	81	222	419				1507				2205		
	Block A2	162	444	838				3014				4410		
	Block S1	-	-	241				-				-		
	Block S2	-	-	482				-				-		

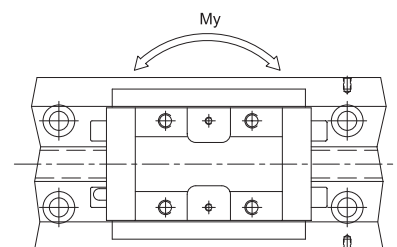
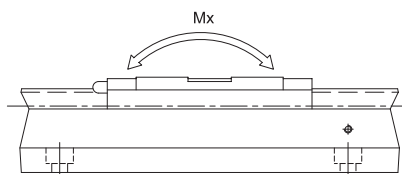
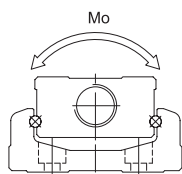

5. Accuracy Grade

Model	Rail Length	Repeatability		Accuracy		Running Parallelism		Starting Torque(N-cm)	
		Precision	Normal	Precision	Normal	Precision	Normal	Precision	Normal
KK40	100	±0.003	-	0.020	-	0.010	-	1.2	-
	150								
	200								
KK50	150	±0.003	-	0.020	-	0.010	-	4	-
	200								
	250								
	300								
KK60	150	±0.003	±0.01	0.020	-	0.010	-	15	7
	200								
	300								
	400								
	500								
KK86	150	±0.003	±0.01	0.025	-	0.015	-	15	10
	200								
	300								
	400								
	500								
	600								
KK100	340	±0.003	±0.01	0.030	-	0.020	-	17	10
	440								
	540								
	640								
	740								
KK100	740	±0.005	-	0.035	-	0.025	-	17	-
	940								
	980								
	1080								
	1180								
KK100	1180	±0.005	-	0.040	-	0.030	-	20	-
	1280								
	1380								

6. Motor and motor adaptor flange

6-1 Motor and motor adaptor flange

Motor	Model	KK40	KK50	KK60	KK86	KK100	
AC servo motor	Panasonic	MSM3AZ(30W)	F2	F2	F2	F3	
		MSM5AZ(50W)					
		MSM01(100W)					
		MSM02(200W)					
		MSM04(400W)					
		MSM08(750W)					
	Mitsubishi	HC-PQ033(30W)	F1	F1	F1	F2	
		HC-PQ053(50W)					
		HC-PQ13(100W)					
		HC-PQ23(200W)					
		HC-MF053(50W)					
		HC-MF13(100W)					
		HC-MF23(200W)					
	HC-MF43(400W)						
	Kawasaki	SGM-A3(30W)		F1	F1	F2	
SGM-A5(50W)							
SGM-01(100W)							
SGM-02(200W)							
SGM-04(400W)							
SGM-08(750W)							
Stepping	VEXTA	PK24/Nema17	F3	F3	F5		
		PK26/Nema23		(F-E2)	F4	F6	
		PK29/Nema34					F4
		PK54		F3	F5		
		PK56		(F-E1)		F5	
		PK59					F3

* Others type of motor can be designed.

6-2 Motor Adaptor Flange

KK40

Motor Adaptor Flange F0

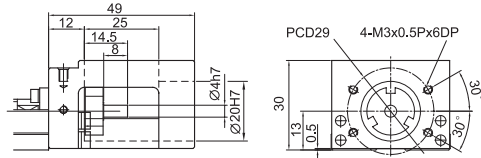

Motor Adaptor Flange F2

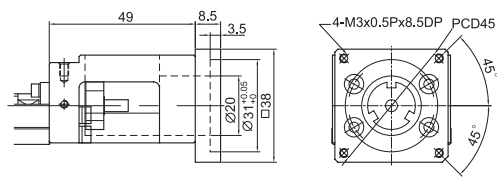

Motor Adaptor Flange F1

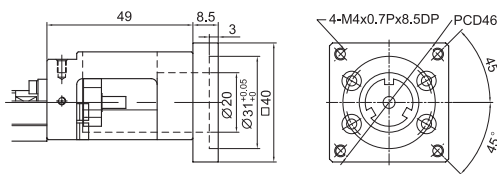

Motor Adaptor Flange F3

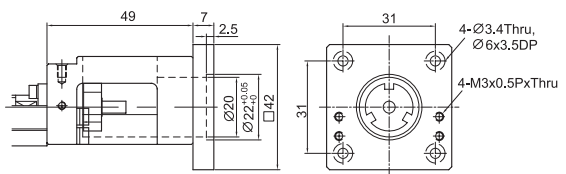

KK50

Motor Adaptor Flange F0

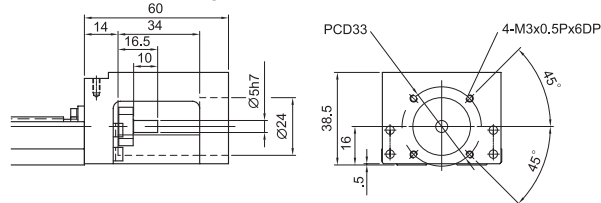

Motor Adaptor Flange F2

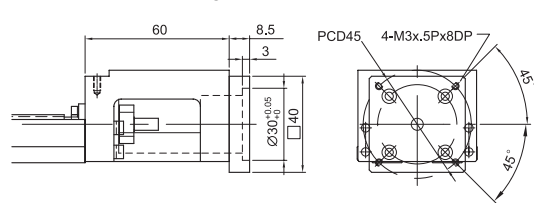

Motor Adaptor Flange F1

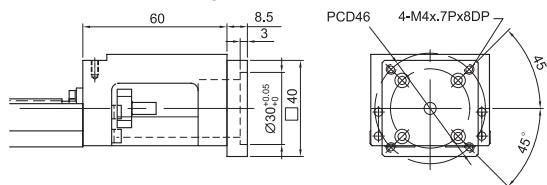

Motor Adaptor Flange F3

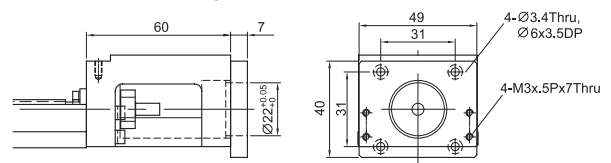

KK60

Motor Adaptor Flange F0

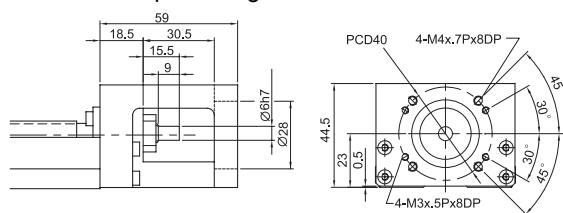

Motor Adaptor Flange F3

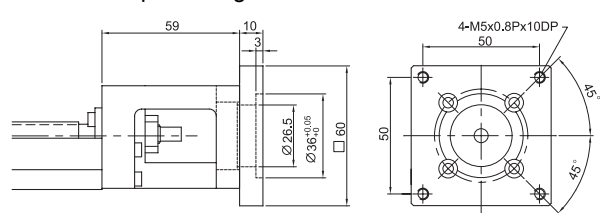

Motor Adaptor Flange F1

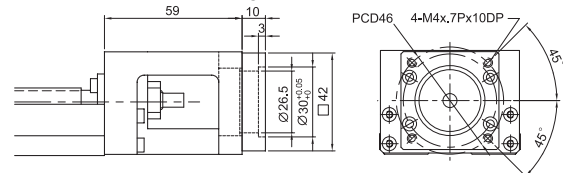

Motor Adaptor Flange F4

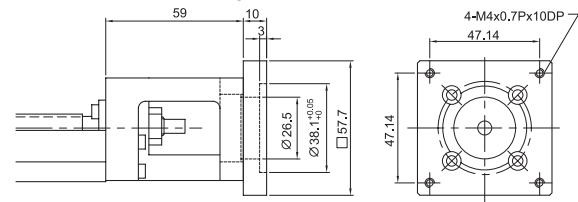

Motor Adaptor Flange F2

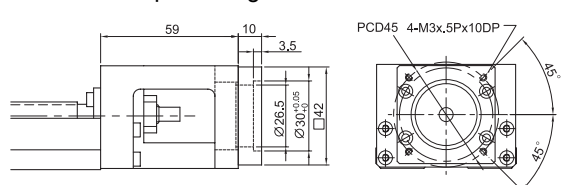

Motor Adaptor Flange F5

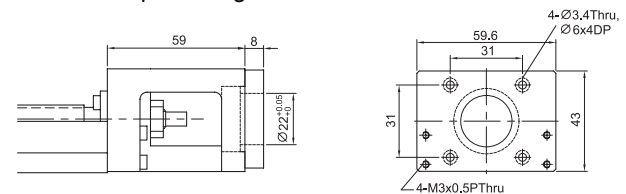

KK86

Motor Adaptor Flange F0

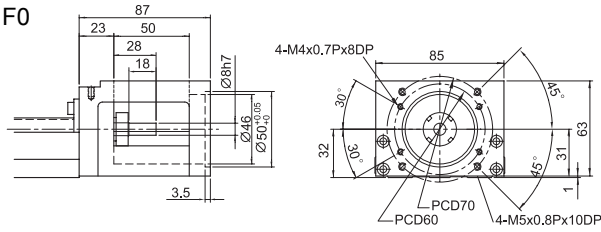

Motor Adaptor Flange F1

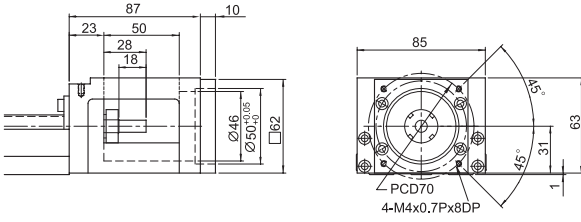

Motor Adaptor Flange F4

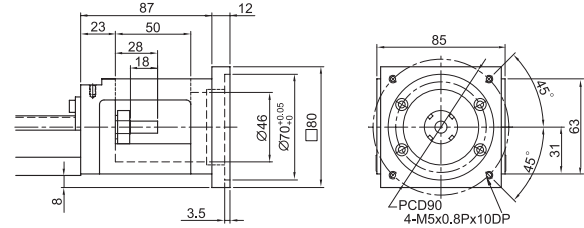

Motor Adaptor Flange F2

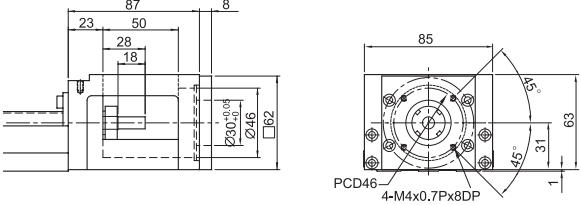

Motor Adaptor Flange F5

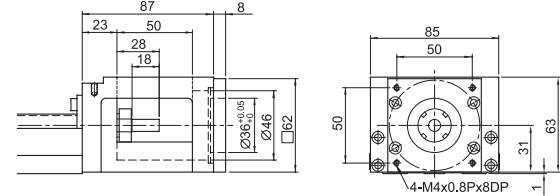

Motor Adaptor Flange F3

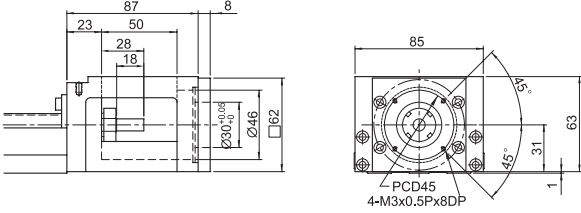

Motor Adaptor Flange F6

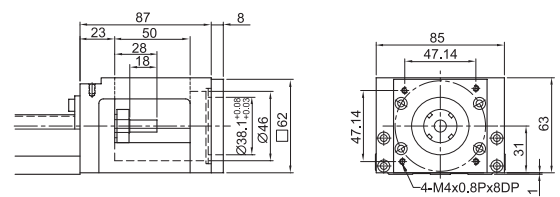

KK100

Motor Adaptor Flange F0

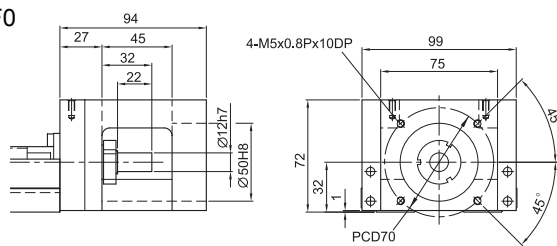

Motor Adaptor Flange F1

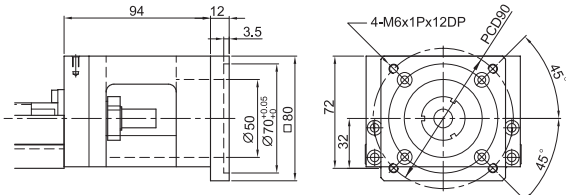

Motor Adaptor Flange F3

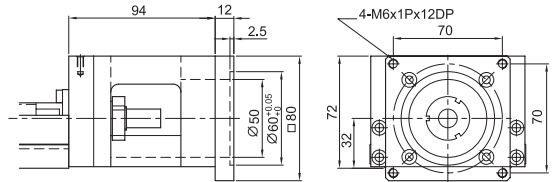

Motor Adaptor Flange F2

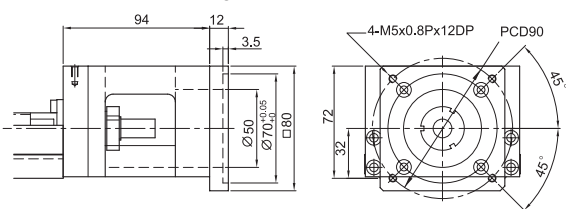

Motor Adaptor Flange F4

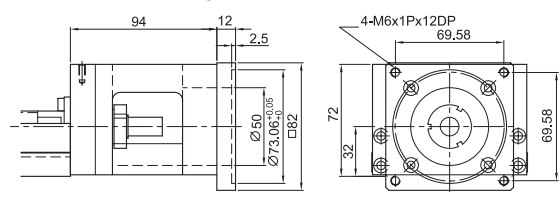

7. Optional function

7-1 Bellows

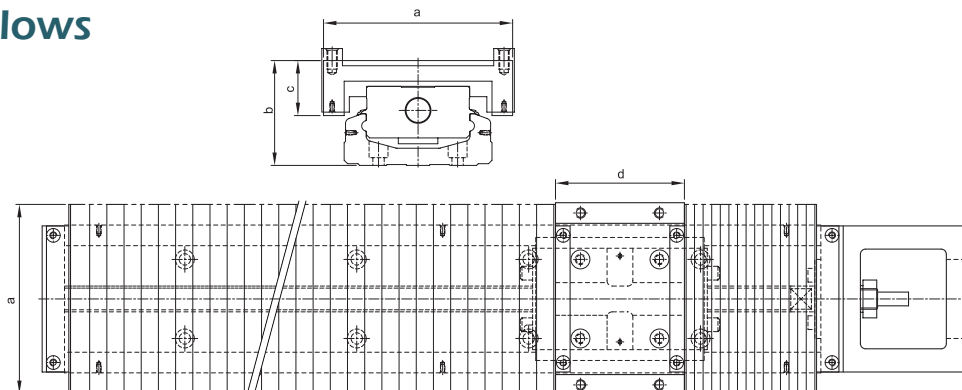

Nominal Width	Rail length	Stroke	Min.	Max.	a	b	c	d
KK60	150	56	16	80	84	45.5	24	54
	200	106	20	126				
	300	166	40	206				
	400	234	56	290				
	500	306	70	376				
	600	366	90	456				
KK86	340	188	36	224	110	61	32	75
	440	260	50	310				
	540	336	62	398				
	640	408	76	484				
	740	480	90	570				
	940	640	110	750				

7-2 Switch

Switch rail

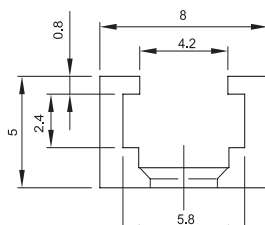

Switch

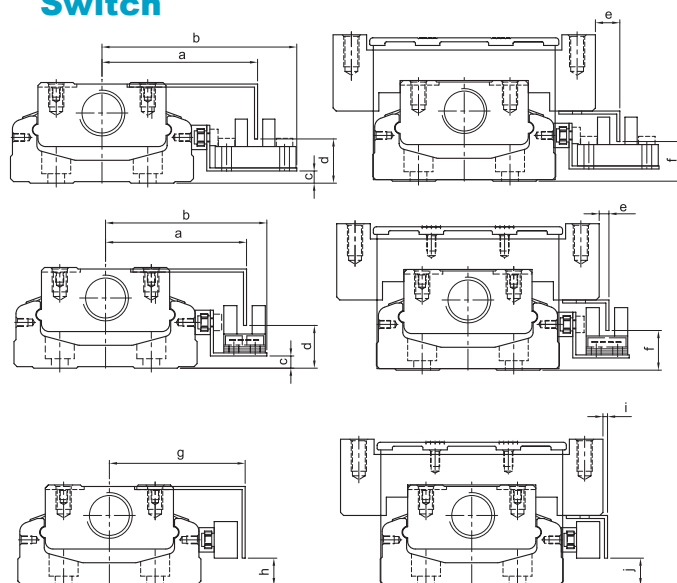

Nominal Width	a	b	c	d	e	f
KK50	45.5	59	1	10	15	11
KK60	51	63.8	4	14.5	8	13
KK86	63.5	76.7	8	18	8	18
KK100						

Switch 1: Omron EE-SX671

Nominal Width	a	b	c	d	e	f
KK50	41.3	48	1	10.5	10.2	11
KK60	46.2	52.8	4	14	3.2	13
KK86	59	65.7	8	18	3	18
KK100						

Switch 2: Omron EE-SX674

Nominal Width	g	h	i	j
KK40				
KK50	39.5	5.7	7	19.5
KK60	44.5	9	2	9
KK86	57	13	1	13
KK100				

Switch 3, 4: SUNX GL-12F, GL-N12F-PX10

8. Life

Three main components of the linear stage KK are guideway, ballscrew and bearing. The calculation formulas of their life are shown as follows:

8-1 Guideway

$$L = \left(\frac{f_t}{f_w} \cdot \frac{C}{P_n} \right)^3 \times 50\text{km}$$

L : Life Rating (km) C : Basic Dynamic Load Rating (N)
 f_t : Contact Coefficient (ref. Table 1) P_n : Calculating Loading (N)
 f_w : Loading Coefficient (ref. Table 2)

Table 1

Block type	Contact Coefficient f_t
A1, S1	1.0
A2, S2	0.81

Table 1

Operating Condition		Loading Coefficient f_w
Thrust and Vibration	Velocity (V)	
No Thrust	V < 15m/min	1.0~1.5
Low Vibration	15m/min < V < 60m/min	1.5~2.0
High Vibration	V > 60m/min	2.0~3.5

8-2 Ballscrew and Bearing

$$L = \left(\frac{1}{f_w} \cdot \frac{C_a}{P_{a,n}} \right)^3 \times 10^6 \text{ rev}$$

L : Life Rating (rev.) C_a : Basic Dynamic Load Rating (N)
 f_w : Loading Coefficient (ref. Table 2) $P_{a,n}$: Axial Loading (N)

9. Lubrication

Replenishing the grease every 100km

Number of Block 1

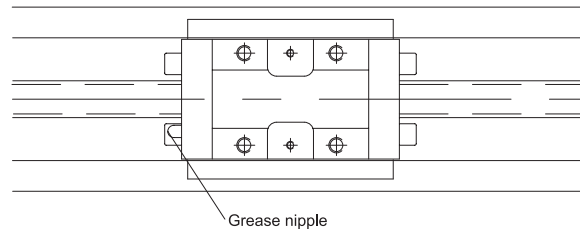

Number of Block 2

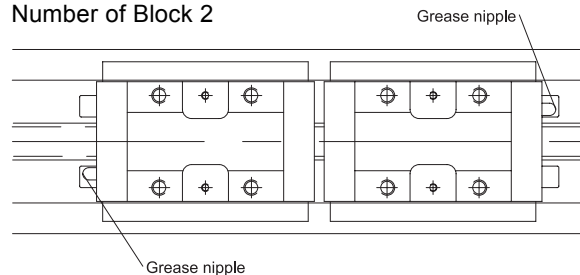

10. Dimension

10-1 Without Cover

KK40

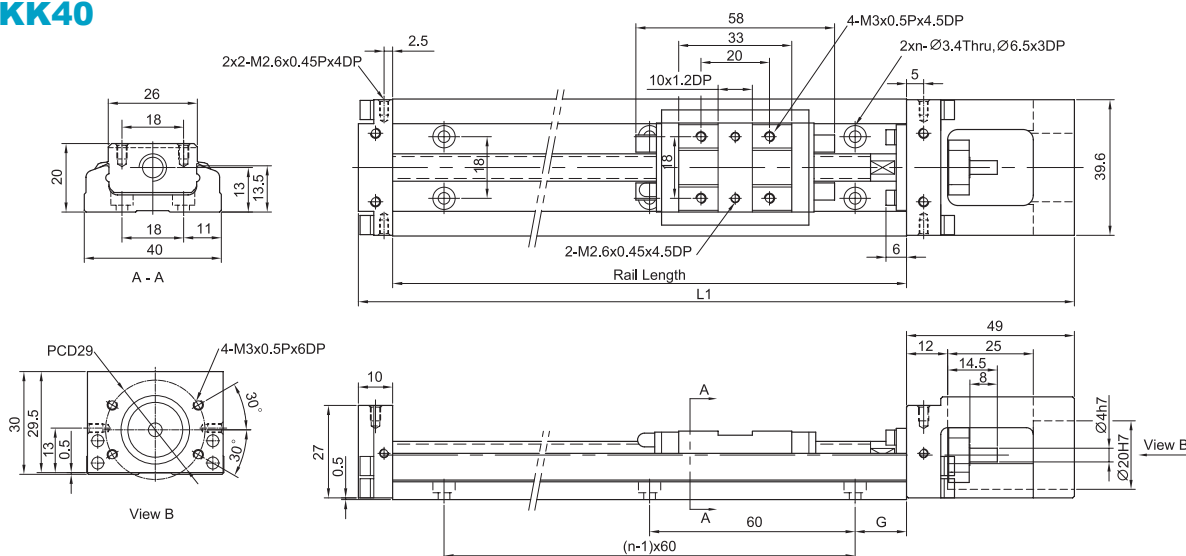

Rail Length (mm)	Total Length L1 (mm)	Maximum Stroke (mm)		G (mm)	n (mm)	Mass (kg)	
		A1 Block	A2 Block			A1 Block	A2 Block
100	159	36	-	20	2	0.48	-
150	209	86	34	15	3	0.6	0.67
200	259	136	84	40	3	0.72	0.79

KK50

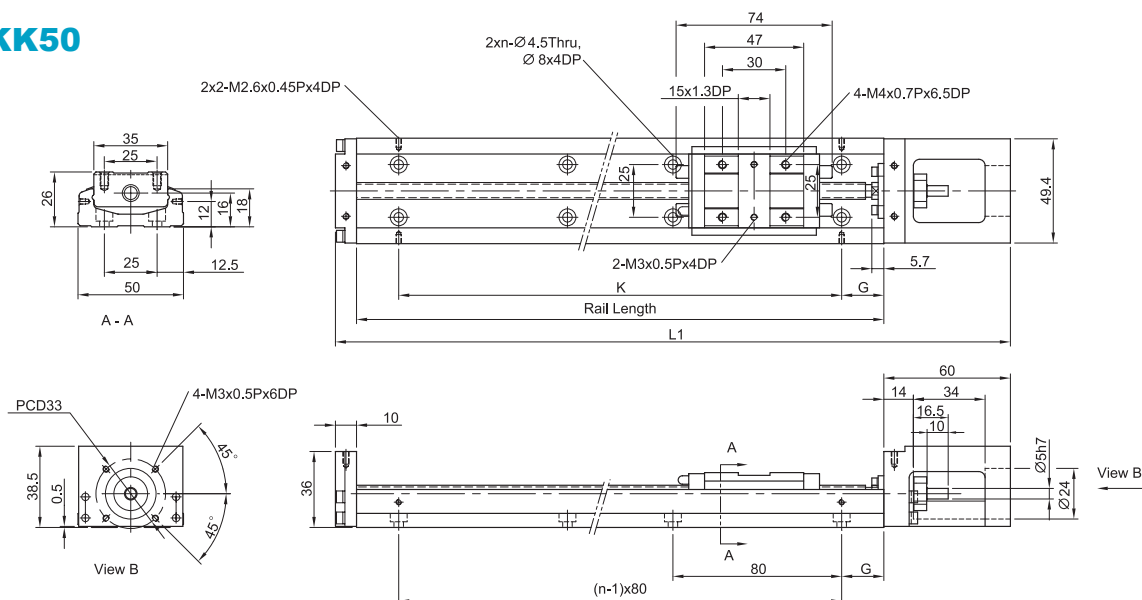

Rail Length (mm)	Total Length L1 (mm)	Maximum Stroke (mm)		G (mm)	m (mm)	n	Mass (kg)	
		A1 Block	A2 Block				A1 Block	A2 Block
150	220	70	-	35	80	2	1	-
200	270	120	55	20	160	3	1.2	1.4
250	320	170	105	45	160	3	1.4	1.6
300	370	220	155	30	240	4	1.6	1.8

KK60

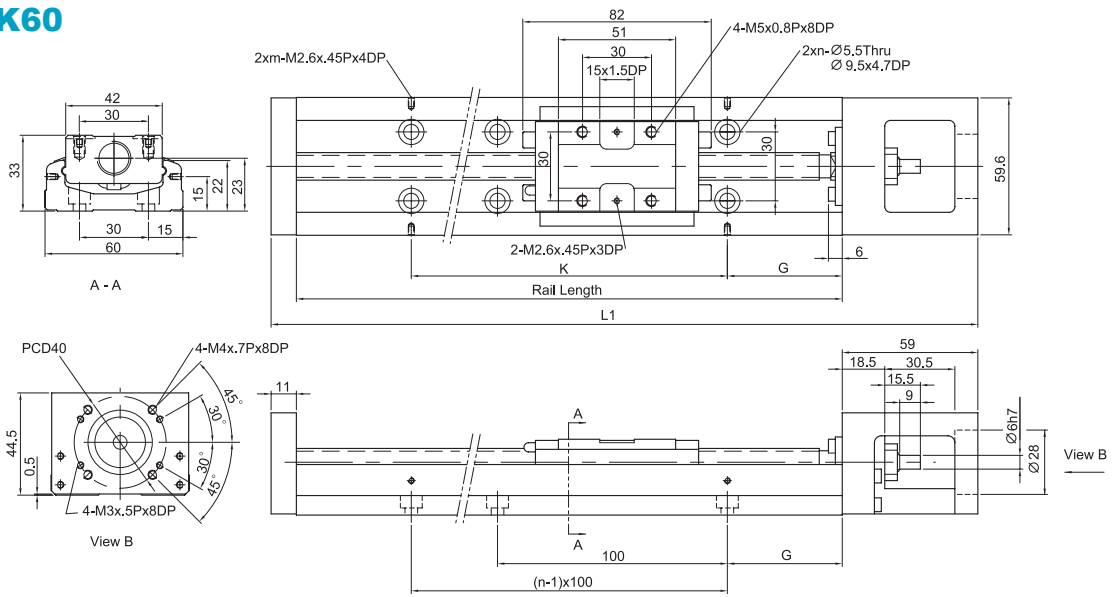

Rail Length (mm)	Total Length L1 (mm)	Maximum Stroke (mm)		G (mm)	K (mm)	n	m	Mass (kg)	
		A1 Block	A2 Block					A1 Block	A2 Block
150	220	60	-	25	100	2	2	1.5	-
200	270	110	-	50	100	2	2	1.8	-
300	370	210	135	50	200	3	2	2.4	2.7
400	470	310	235	50	100	4	4	3	3.3
500	570	410	335	50	200	5	3	3.6	3.9
600	670	510	435	50	100	6	6	4.2	4.6

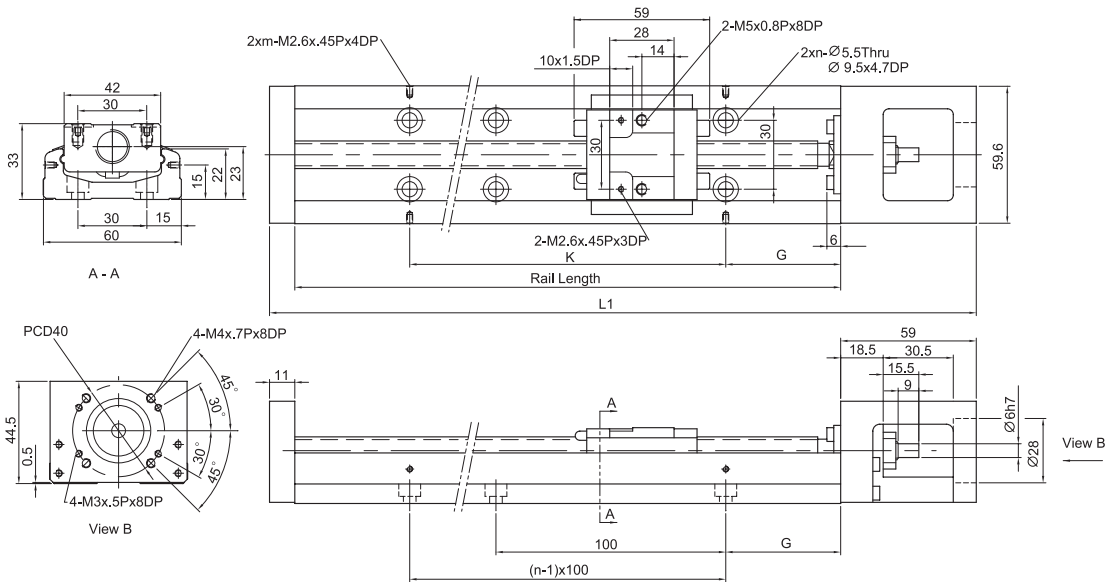

Rail Length (mm)	Total Length L1 (mm)	Maximum Stroke (mm)		G (mm)	K (mm)	n	m	Mass (kg)	
		S1 Block	S2 Block					S1 Block	S2 Block
150	220	85	34	25	100	2	2	1.4	1.6
200	270	135	184	50	100	2	2	1.7	1.9
300	370	235	184	50	200	3	2	2.3	2.5
400	470	335	284	50	100	4	4	2.9	3.1
500	570	435	384	50	200	5	3	3.5	3.7
600	670	535	484	50	100	6	6	4.1	4.3

KK86

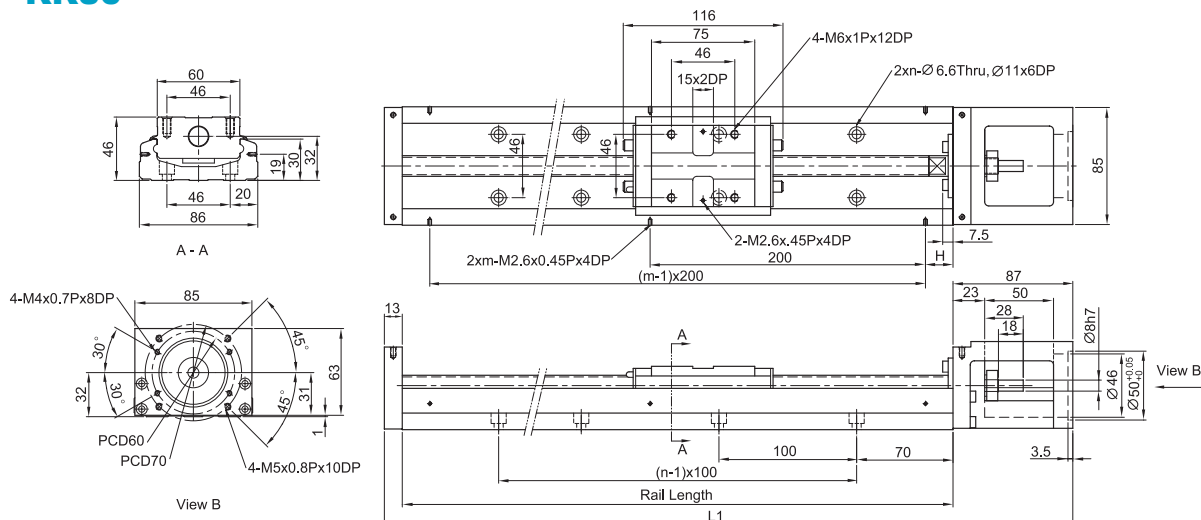

Rail Length (mm)	Total Length L1 (mm)	Maximum Stroke (mm)		G (mm)	n	m	Mass (kg)	
		A1 Block	A2 Block				A1 Block	A2 Block
340	440	210	100	70	3	2	5.7	6.5
440	540	310	200	20	4	3	6.9	7.7
540	640	410	300	70	5	3	8.0	8.8
640	740	510	400	20	6	4	9.2	10.0
740	840	610	500	70	7	4	10.4	11.2
940	1040	810	700	70	9	5	11.6	12.4

KK100

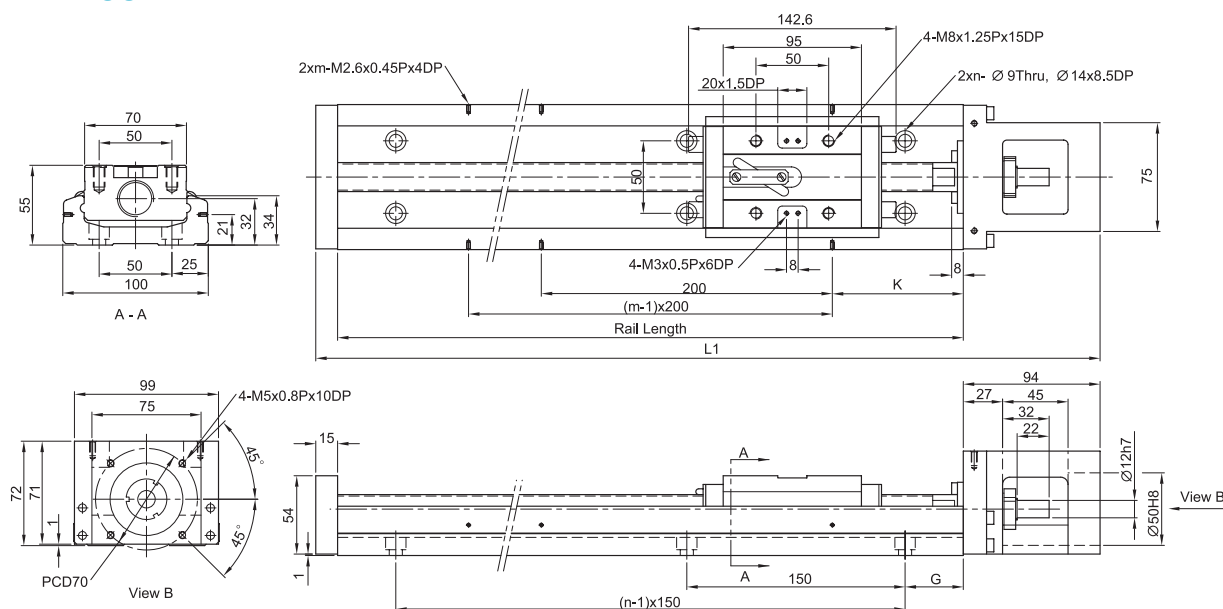

Rail Length (mm)	Total Length L1 (mm)	Maximum Stroke (mm)		G (mm)	K (mm)	n	m	Mass (kg)	
		A1 Block	A2 Block					A1 Block	A2 Block
980	1089	828	700	40	90	7	5	18.6	20.3
1080	1189	928	800	15	40	8	6	20.3	22.0
1180	1289	1028	900	65	90	8	6	22.0	23.7
1280	1389	1128	1000	40	40	9	7	23.6	25.3
1380	1489	1228	1100	15	90	10	7	25.3	27.0

10-2 With Cover

KK40

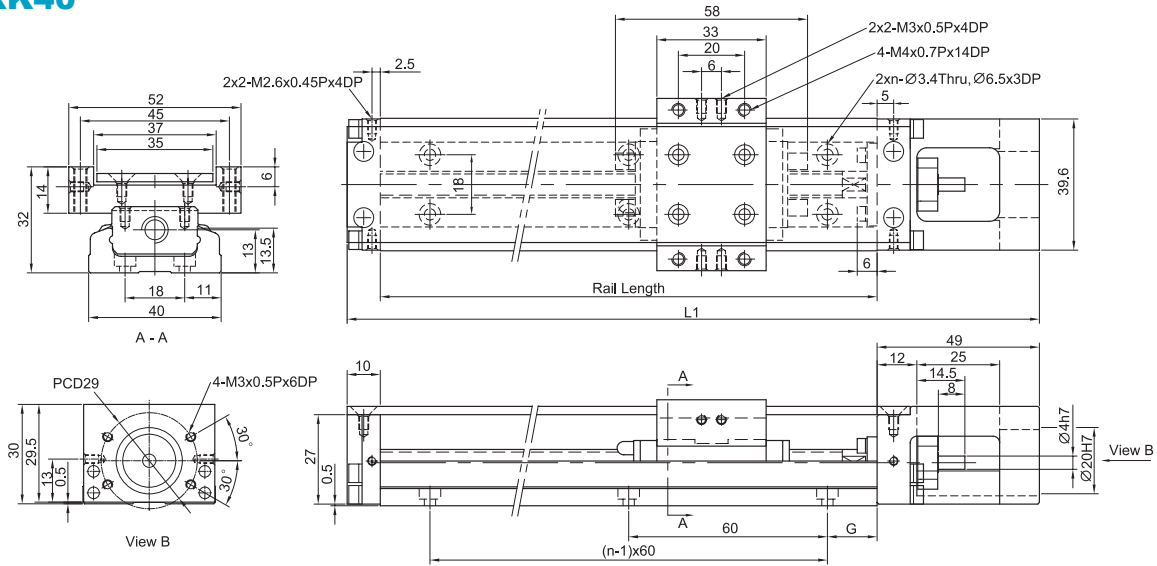

Rail Length (mm)	Total Length L1 (mm)	Maximum Stroke (mm)		G (mm)	n (mm)	Mass (kg)	
		A1 Block	A2 Block			A1 Block	A2 Block
100	159	36	-	20	2	0.55	-
150	209	86	34	15	3	0.68	0.76
200	259	136	84	40	3	0.82	0.89

KK50

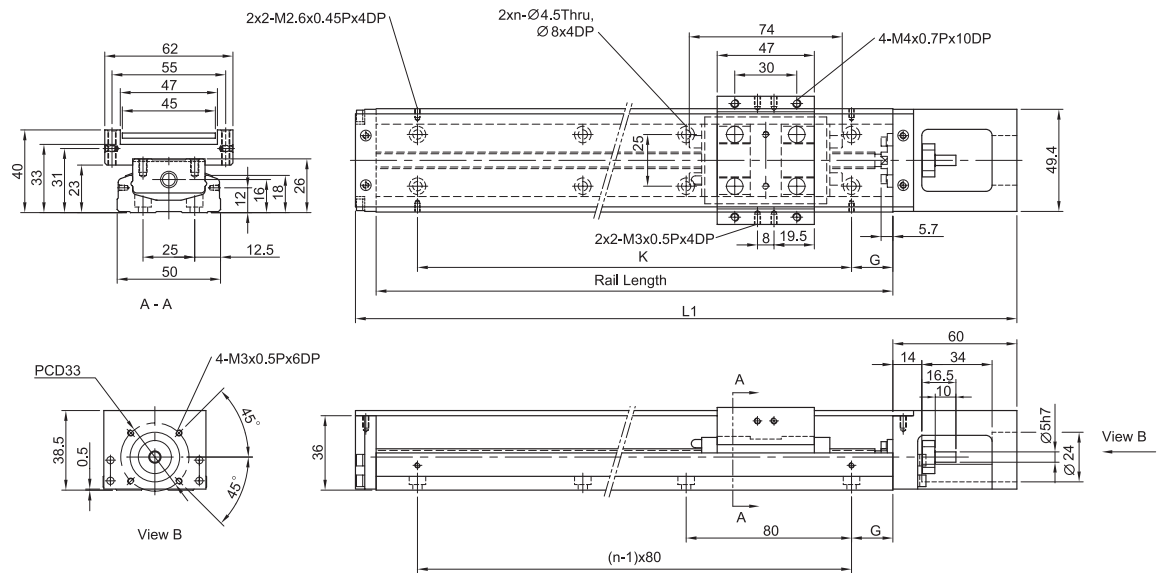

Rail Length (mm)	Total Length L1 (mm)	Maximum Stroke (mm)		G (mm)	m (mm)	n	Mass (kg)	
		A1 Block	A2 Block				A1 Block	A2 Block
150	220	70	-	35	80	2	1.1	-
200	270	120	55	20	160	3	1.3	1.5
250	320	170	105	45	160	3	1.6	1.8
300	370	220	155	30	240	4	1.8	2.0

KK60

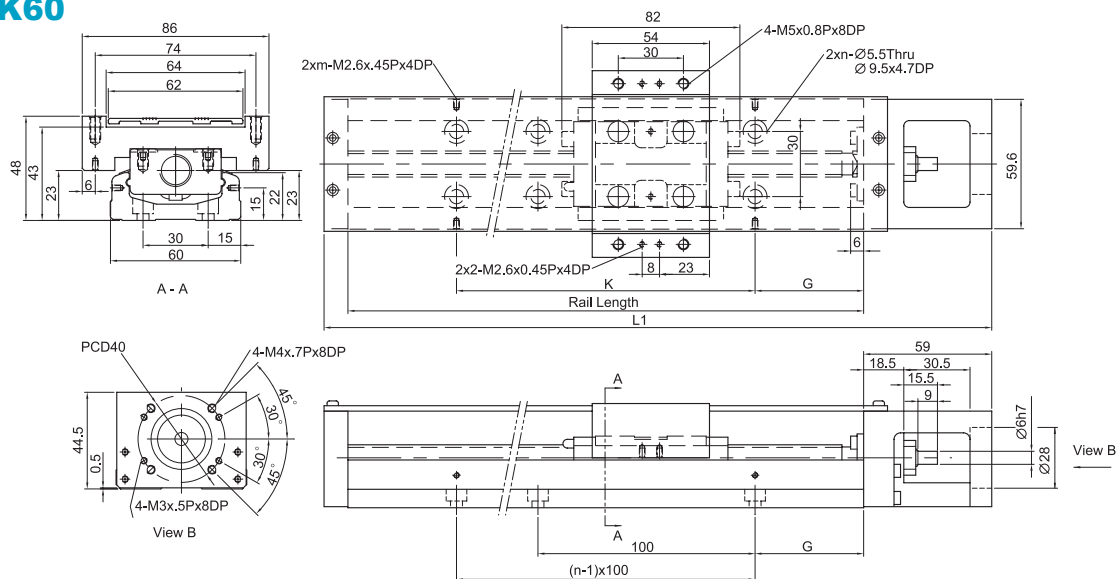

Rail Length (mm)	Total Length L1 (mm)	Maximun Stroke (mm)		G (mm)	K (mm)	n	m	Mass (kg)	
		A1 Block	A2 Block					A1 Block	A2 Block
150	220	60	-	25	100	2	2	1.7	-
200	270	110	-	50	100	2	2	2.1	-
300	370	210	135	50	200	3	2	2.7	3.0
400	470	310	235	50	100	4	4	3.3	3.6
500	570	410	335	50	200	5	3	3.9	4.2
600	670	510	435	50	100	6	6	4.6	5.0

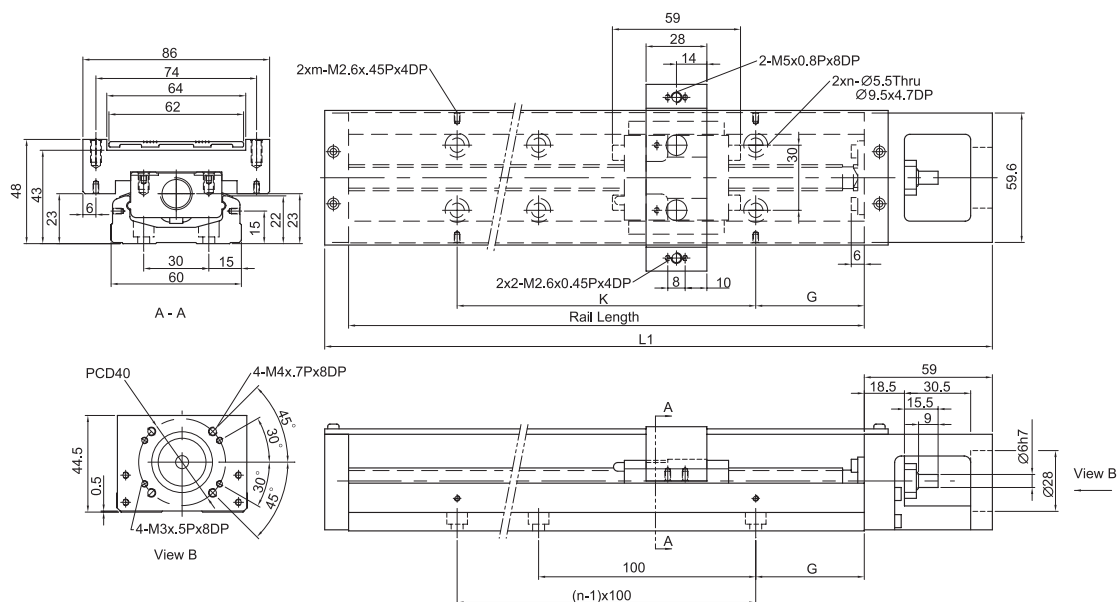

Rail Length (mm)	Total Length L1 (mm)	Maximun Stroke (mm)		G (mm)	K (mm)	n	m	Mass (kg)	
		S1 Block	S2 Block					S1 Block	S2 Block
150	220	85	34	25	100	2	2	1.6	1.8
200	270	135	184	50	100	2	2	1.9	2.1
300	370	235	184	50	200	3	2	2.5	2.7
400	470	335	284	50	100	4	4	3.1	3.3
500	570	435	384	50	200	5	3	3.7	3.9
600	670	535	484	50	100	6	6	4.4	4.6

KK86

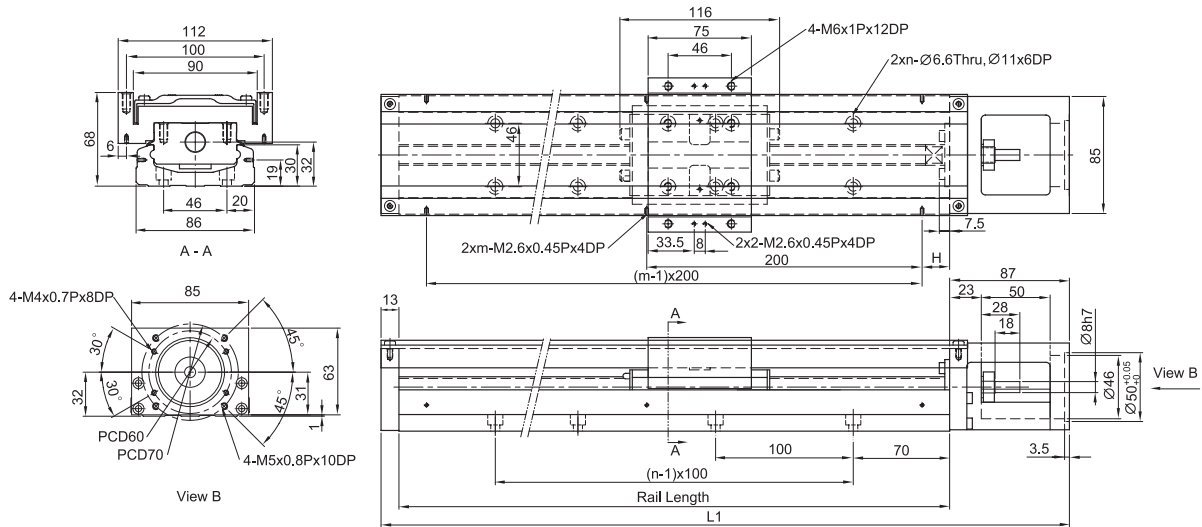

Rail Length (mm)	Total Length L1 (mm)	Maximum Stroke (mm)		G (mm)	n	m	Mass (kg)	
		A1 Block	A2 Block				A1 Block	A2 Block
340	440	210	100	70	3	2	6.5	7.3
440	540	310	200	20	4	3	7.8	8.6
540	640	410	300	70	5	3	9.0	9.8
640	740	510	400	20	6	4	10.3	11.3
740	840	610	500	70	7	4	11.6	12.4
940	1040	810	700	70	9	5	13.0	13.8

KK100

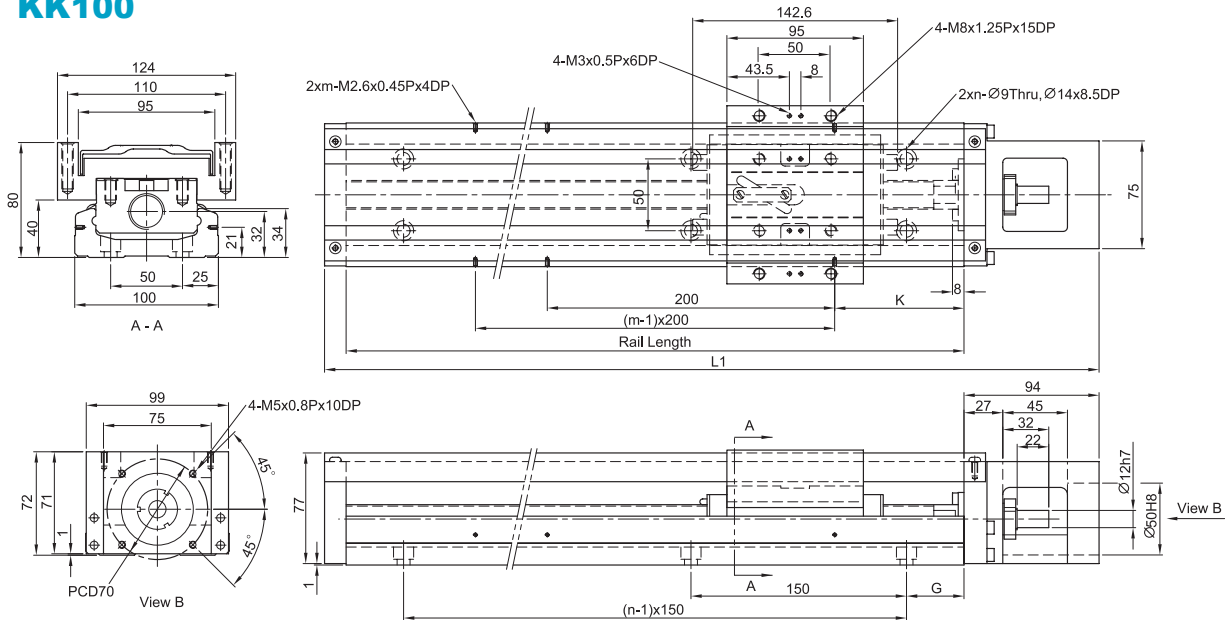

Rail Length (mm)	Total Length L1 (mm)	Maximum Stroke (mm)		G (mm)	K (mm)	n	m	Mass (kg)	
		A1 Block	A2 Block					A1 Block	A2 Block
980	1089	828	700	40	90	7	5	20.4	22.1
1080	1189	928	800	15	40	8	6	22.2	23.9
1180	1289	1028	900	65	90	8	6	24.0	25.7
1280	1389	1128	1000	40	40	9	7	25.7	27.4
1380	1489	1228	1100	15	90	10	7	27.5	29.2