

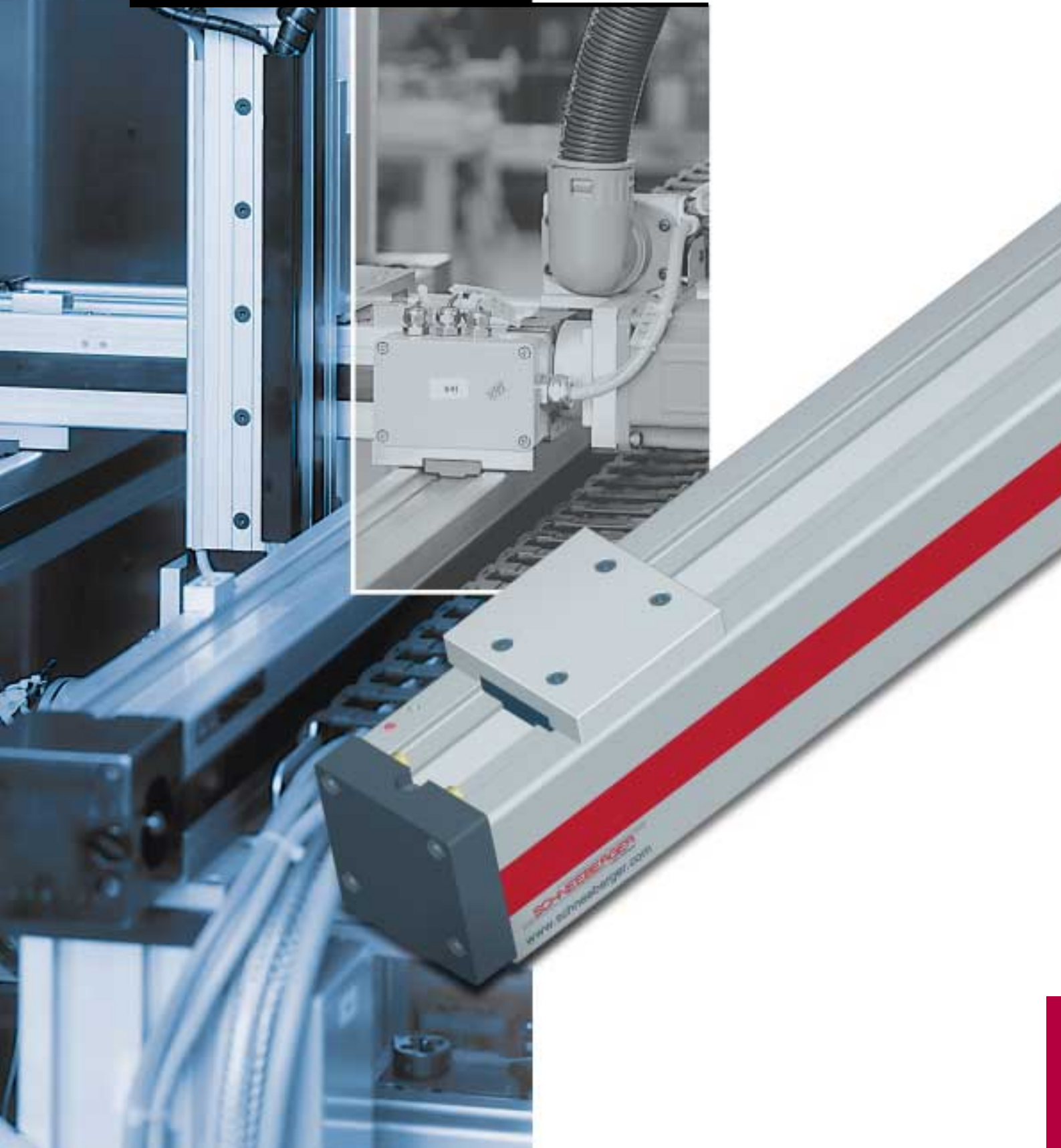


SCHNEEBERGER
LINEAR TECHNOLOGY

automation

AUTOMATION

Linear- and Rotary Modules



SCHNEEBERGER
www.schneberger.com

Table of Contents

1 Product Overview	• 4
1.1 Selection of the Linear Modules	• 8
1.2 Selection of the Rotary Modules	• 9
2 Applications	• 10
3 Technical Data	
3.1 Technical Data Linear Modules ALM	• 11
3.1.1 Deflection and Torsion	• 11
3.1.2 Verification of the Service Lifetime	• 11
3.1.3 Lubrication	• 11
3.1.4 Permissible Operating Temperatures	• 11
3.2 Technical Data Linear Modules ALS	• 12
3.2.1 Deflection and Torsion	• 12
3.2.2 Verification of the Service Lifetime	• 12
3.2.3 Lubrication	• 12
3.2.4 Permissible Operating Temperatures	• 12
3.3 Technical Data Rotary Modules ARS	• 13
3.3.1 Load Bearing Capacity	• 13
3.3.2 Installation Position and Ventilation	• 13
3.3.3 Lubrication	• 13
3.3.4 Permissible Operating Temperatures	• 13
4 Linear Modules ALM	
4.1 Product Characteristics ALM 70	• 14
4.1.1 Dimension Table Type ALM 70-O without Drive	• 16
4.1.2 Dimension Table Type ALM 70-S with Spindle Drive	• 18
4.1.3 Dimension Table Type ALM 70-B with Belt Drive	• 20
4.2 Product Characteristics ALM 80	• 22
4.2.1 Dimension Table Type ALM 80-B with Belt Drive	• 24
4.3 Accessories	• 26
4.4 Ordering Information	• 31
5 Linear Modules ALS	
5.1 Product Characteristics ALS 140	• 34
5.1.1 Dimension Table Type ALS 140-O without Drive	• 36
5.1.2 Dimension Table Type ALS 140-S with Spindle Drive	• 38
5.1.3 Dimension Table Type ALS 140-B with Belt Drive	• 40
5.1.4 Dimension Table Type ALS 140-P with Pneumatic Drive	• 42
5.2 Accessories	• 44
5.3 Ordering Information	• 44
6 Rotary Modules ARS	
6.1 Product Characteristics ARS	• 46
6.2 Technical Data Type ARS-S	• 48
6.3 Technical Data Type ARS-H	• 49
6.4 Dimension Table Type ARS-S	• 50
6.5 Dimension Table Type ARS-H	• 52
6.6 Accessories	• 54
6.7 Ordering Information	• 55

- 7 Motors and Control Systems**
- 7.1 Motors • 56
- 7.2 Control Systems • 56

- 8 Axis Combinations**
- 8.1 General • 57
- 8.2 Installation Arrangements • 57

- 9 Questionnaire for your Application** • 61

- 10 Precautions**
- 10.1 General Safety Information. • 63
- 10.2 Remarks concerning Dangers/Hazards • 63

- 11 The SCHNEEBERGER-Group** • 64

1 Product Overview

2 Applications

3 Technical Data

4 Linear Modules ALM

5 Linear Modules ALS

6 Rotary Modules ARS

7 Motors and Control Systems

8 Axis Combinations

**9 Questionnaire for your
Application**

10 Precautions

11 The SCHNEEBERGER-Group

Linear module ALM

The compact linear module ALM is suitable for universal application as an individual axis or in combination in multi-axis systems. Special adapter plates also enable combination with other sizes and types.

Through the utilization of SCHNEEBERGER MONORAIL BM type profile rail guideways, an accurate guiding accuracy is assured even in the case of high tilting or tipping torques.

The utilization of ball screws or synchronous belts makes both accurate as well as rapid movement possible.

The rigid aluminum profile with recessed slots allows simple mounting of the module in any position by using sliding blocks.

A tape cover effectively protects against contamination from dirt and enables a long service life even under dirty conditions.

Filling the carriages with grease ensures use with minimum maintenance.

Figure 1:
Linear module ALM 70-O



Linear module ALS

The linear module ALS is a precise, ready to install module with high performance characteristics, especially stability, and exceptionally compact construction.

The fulfilment of these exceedingly important characteristics is assured by the rigid aluminum profile in conjunction with hardened steel shafts and precision linear bearings.

This linear module can be driven with a synchronous belt, ball screw or a pneumatic cylinder.

The ball screw drive with a low backlash nut makes high positioning accuracy and repeatability possible.

For extremely fast handling and positioning tasks, the synchronous belt or pneumatic drive is recommended.

The standard U-shaped sheet metal covering protects the built-in elements and enables full use of the maximum stroke compared to units with conventional bellows coverings.

Figure 2:
Linear module ALS 140-O



The prepared lubrication installations make cost-effective maintenance possible and also assure a long service lifetime.

Types and sizes

ALM 70-O without drive
ALM 70-S with ball screw drive
ALM 70-B with belt drive

ALM 80-B with belt drive

Accessories

- 2nd carriage (double carriage) DW
- Integrated reference and limit switches PNP
- Sliding blocks NS
- Adapter plates AP
- Stepping or servo motor, including coupling, housing and installation
- Control system and controller

Special versions

- Special strokes
- Lubrication connection
- Sealing air
- Reference and limit switches mounted externally
- Ball screw drive with side mounted motor
- Synchronous drive of two parallel modules
- 2 carriages working in opposite directions in case of ALM 70-B with belt drive

Types and sizes

ALS 140-O without drive
ALS 140-S with ball screw drive
ALS 140-B with belt drive
ALS 140-P with pneumatic cylinder

Accessories

- Double carriage and double table plate DW
- Enhanced load bearing capacity by means of special bushings H
- Inductive reference and limit switches PNP
- Stepping or servo motor, including coupling, housing and installation
- Control system and controller

Special versions

- Special strokes
- Limit stop damper in case of ALS-P
- Ball screw drive with side mounted motor
- Synchronous drive of two parallel modules

Rotary module ARS

As a complement to the linear modules, the rotary module ARS was developed. All rotating elements move inside an oil bath. The sealed housing allows any required vertical and horizontal installation positions. Through the utilization of the optimally dimensioned cross-roller bearings for the rotating table, these modules are able to support very high axial and radial loads. With single or double-bearing supports for the working gear shafts, rapid positioning as well as precise reversing operation is possible. The worm gear drive, through an eccentric cam, can be adjusted to have practically no play (backlash). The drive consists of a carefully selected, low-wear combination of materials. The amply dimensioned through bore is well suited for applications requiring a clearance passage and for handling wires or cables.

Figure 3:
Linear module ARS 100



Motors and control systems

As an option, all linear and rotary modules can be equipped with drive systems.

Available for selection are commercially available motors (2-, 3- or 5-phase stepping motors or DC/AC servomotors) and universal CNC- and SPS control systems.

Service

SCHNEEBERGER offers a complete handling of customer projects right from the beginning and up to and including the after-sales service.

Our sales engineers are able to help you with the selection of the suitable components. For your design, CAD drawing patterns are available in the Internet under www.schneeberger.com.

Quality

SCHNEEBERGER is a company certified in accordance with DIN EN ISO 9001. Therefore a consistent high quality of products supplied is assured.

Every linear and rotary module produced has its own identification number. With this, the traceability in case of servicing or maintenance is still assured even after many years of service.

Types and sizes

ARS 100-S
ARS 100-H
ARS 200-S
ARS 200-H
ARS 300-S
ARS 300-H

Accessories

- Inductive reference switch PNP
- Base plate for horizontal utilization BH
- Base plate for vertical utilization BV
- Table plates with or without T-slots
- Stepping or servomotor, including coupling, housing and installation
- Control system and controller

1.1 Selection of the Linear Modules

For the selection, the most unfavorable operating conditions should be taken into account. The following tables will assist you in making a preliminary selection. The loads and accelerations occurring must not exceed the load-bearing capacities of the linear modules. We will be happy to assist you in verifying your selection.

Maximum stroke (mm)					
810	1000	1500	2500	6740	12 000
ALM 70-S	ALM 140-P	ALS 140-S	ALM 70 ALM 70-B ALS 140-O ALS 140-B	ALM 80-B (one-part)	ALM 80-B (multi-part)

Absolute positioning accuracy (mm/m)			
± 0.3/0.3	± 0.15/0.3	± 0.1/0.3	± 0.05/0.3
ALM 80-B	ALM 70-B ALS 140-B ALS 140-S-K16×50*	ALS 140-S-K16×16*	ALM 70-S ALS 140-S-K12×5 ALS 140-S-K16×10

Maximum static central load (N)							
500	1000	1600	2000	3200	3600	4000	7200
ALM 70-1	ALM 70-2	ALM 80-1	ALS 140-1	ALM 80-2	ALS 140-1-H	ALS 140-2	ALS 140-2-H

Maximum axial load (N)		
400	500	1000
ALS 140	ALM 70	ALM 80

Maximum speed (m/s)						
0.2	0.3	0.5	1.0	1.5	2.0	3.5
ALS 140-S-K12×5	ALS 140-S-K16×10 ALM 70-S	ALS 140-S-K16×16*	ALS 140-B-16T5 ALS 140-S-K16×50*	ALS 140-B-25T5 ALM 70-B	ALS 140-B-25AT5	ALM 80-B

Maximum recommended load to be moved (N) in case of high dynamism					
50	100	200	300	400	800
ALM 70-B ALS 140-P	ALM 70-S ALS 140-B-16T5	ALS 140-B-25T5	ALS 140-B-25AT5	ALS 140-S	ALM 80-B

Feed per motor revolution without gearing (mm)						
5	10	16	50	60	105	192
ALS 140-S-K12×5	ALS 140-S-K16×10 ALM 70-S	ALS 140-S-K16×16*	ALS 140-S-K16×50* ALS 140-B-16T5 ALM 70-B	ALS 140-B-25T5	ALS 140-B-25AT5	ALM 80-B

* only available on special request

Support recommended as from (mm)	
500	1000
ALS 140 ALM 70	ALM 80

Installation position	
Horizontal	Vertical
Belt Ball screw Pneumatics	Belt with brake motor recommended Ball screw with brake motor recommended

1.2 Selection of the Rotary Modules

For the selection, the most unfavorable operating conditions should be taken into account. The following tables will assist you in making a preliminary selection. The loads must not exceed the load-bearing capacities of the rotary modules. We will be happy to assist you in verifying your selection.

Type	Bearing support of worm gear	Reversing operation possible	Maximum central load (N)	Maximum speed of rotation (°/s)	Positioning accuracy (°)	Dimensions W×H (mm)
ARS 100-S	Single	–	8 500	180	±0.05	149×79
ARS 200-S		–	13 500	180	±0.02	200×84
ARS 300-S		–	45 000	150	±0.015	299×125
ARS 100-H	Double	x	8 500	180	±0.05	160×93
ARS 200-H		x	14 000	180	±0.02	225×92
ARS 300-H		x	35 000	150	±0.015	331×126

All SCHNEEBERGER linear- and rotary modules combine the principal tasks of driving, transporting and positioning.

The modules are successfully utilized in all fields of industry for the automation of manufacturing sequences and for assembly and handling tasks.

Together with the matched accessories and the connection elements, a great many industrial handling and automation problems can be solved rapidly, efficiently and cost-effectively.

The SCHNEEBERGER linear modules have been especially designed for dynamic and robust requirements and therefore provide excellent results with a long service life. Furthermore, as a result of the components utilized inside and of the rigid self-supporting aluminum profile, high load-bearing capacities and rigidities are achieved.

The main application fields are handling and automation tasks for the

- Automobile industry
- Printing industry
- Glass processing machines
- Semiconductor technology
- Wood processing machines
- Food products
- Medical technology
- Sorting machines
- Injection molding machines
- Textile machines
- Packaging machines
- Machine tools



Automation and handling system in a machine tool

3.1 Technical Data Linear Modules ALM

3.1.1 Deflection and Torsion

In certain application cases, e.g. a gantry superstructure with a long self-supporting transverse axis, verification of the deflection, and of the torsion is necessary. These values have an influence on the movement and positioning accuracy and have an effect on the service lifetime of the guideway.

3.1.2 Verification of the Service Lifetime

As a rule, the service lifetime of a linear module ALM is determined by the linear bearing utilized (profile rail guideway with balls). Exceptions can be units with ball screw drives which are subject to very high axial forces, or applications where the linear guideway is only subjected to low loads.

The nominal calculated service lifetime L of a ball linear guideway is calculated using

$$L = (C/P)^3 \cdot 100 \text{ km}$$

C dynamic load value (N)
 P equivalent force (N)

The built-in high-performance profile rail guideways of the type SCHNEEBERGER MONORAIL BM have an equal load bearing capacity independent of the direction of the load. A reduction of the load value in case of, e. g., tensile loads, is not necessary.

3.1.3 Lubrication

All ball bearings which support the ball screw, or the drive and reversing shafts of the belt drives are lifetime lubricated.

The ball screws and linear guideways are **grease lubricated** and therefore low-maintenance. The first grease fill ex factory as a rule is sufficient for a running distance of at least 1000 km.

It is recommended, that re-greasing occur at least every 3 months. In case of unfavorable conditions such as high loads, a hot climate, dirty ambient conditions and highly dynamic application cases, a more frequent re-greasing is necessary.

The recommendations listed above only serve as a guideline and they are not binding. An accurate determination of the re-greasing time intervals can only be carried out under actual operating conditions.

In case of servicing, the elements can be re-greased with **Klüber type Isoflex NBU 15** or an equivalent high-performance grease.

In case of the module ALM 70, the central lubrication connection has to be ordered as an option.

3.1.4 Permissible Operating Temperatures

Linear modules ALM can be utilized at operating temperatures from -10 °C up to $+70\text{ °C}$.

3.2 Technical Data Linear Modules ALS

3.2.1 Deflection and Torsion

In certain application cases, e. g. a gantry superstructure with a long self-supporting transverse axis, verification of the deflection, and of the torsion is necessary. These values have an influence on the movement and positioning accuracy and have an effect on the service lifetime of the guideway.

3.2.2 Verification of the Service Lifetime

As a rule, the service lifetime of a linear module ALS is determined by the linear bearing utilized (linear ball bearings). Exceptions can be units with ball screw drives, which are subject to very high axial forces or applications where the linear guideway is only subject to low loads.

The nominal calculated service lifetime L of a linear ball bearing in a simplified manner is calculated from:

$$L = (C/P)^3 \cdot 100 \text{ km}$$

C dynamic load value (N)
 P equivalent force (N)

For the load value C , the respective load direction (tension, compression) has to be taken into account, since there are differing values for these.

3.2.3 Lubrication

General Information

All ball bearings which support the ballscrew, or the drive and reversing shafts of the belt drives are lifetime lubricated.

The ball screws and the linear guideways are **grease lubricated** and therefore low-maintenance. The first grease fill ex factory as a rule is sufficient for a running distance of at least 1000 km.

The required values for the re-lubrication quantities and the re-lubrication time intervals are dependent on the actual intervals operating conditions and can vary significantly (refer to lubrication time intervals).

In the case of servicing, the elements can be re-lubricated with **Klüber type Isoflex NBU 15** or a high-performance grease through the grease nipples situated on the lateral bracket.

In the case of the single carriage, two grease nipples (on the front and back side) have to be greased. They may also be located on the same side. In the case of double carriages, all four grease nipples have to be greased separately.

Lubrication Intervals

It is recommended to re-grease at least once a month.

In the case of unfavorable conditions, such as high loads, a hot climate, dirty ambient conditions (e. g., grinding dust, emulsions, etc.) and highly dynamic cases of application, a weekly re-greasing is necessary.

A generally applicable rule is: It is better to grease a little than not at all!

The recommendations listed above only serve as a guideline and they are not binding. An accurate determination of the re-greasing time intervals can only be carried out under actual operating conditions.

3.2.4 Permissible Operating Temperatures

Linear modules ALS can be used at operating temperatures between -10 °C and $+70\text{ °C}$.

3.3 Technical Data Rotary Modules ARS

3.3.1 Load Bearing Capacity

For verification as to which product is most suitable for the application, a mathematically calculated consideration of the application is absolutely indispensable. This is carried out by SCHNEEBERGER.

In case the rotary modules ARS-S (with single support bearing for worm gear shaft) are used in a reversing operation, inaccuracies may occur because the permissible torques for clockwise- / counter-clockwise operation are different. For this reason, the double bearing supported worm gear shafts (type ARS-H) are recommended for reversing operation.

3.3.2 Installation Position and Ventilation

During transportation and storage, all ventilation bores are tightly closed with stop plugs. The one on top has to be replaced by the venting plug supplied as part of the standard scope of supply.

In the case of a position of the motor vertically upwards, an additional lubrication bore for the upper worm gear is absolutely necessary. When placing an order, this installation position has to be specified.

3.3.3 Lubrication

The high-performance lubricating oil factory-filled in the rotary modules has to be replaced no later than 5 years after delivery from the SCHNEEBERGER factory. In the case of highly dynamic application cases or dirty ambient conditions, an earlier servicing is recommended.

3.3.4 Permissible Operating Temperatures

Rotary modules ARS can be utilized at operating temperatures between -5°C and $+80^{\circ}\text{C}$.

4.1 Product Characteristics ALM 70

The compact linear module ALM70 is suitable for universal application as an individual axis or in combination with multi-axis systems. Special adapter plates also make possible the combination with other sizes and types.

By using SCHNEEBERGER profile rail guideways type MONORAIL BM 15, a high guiding accuracy is also assured in the case of high tilting torques.

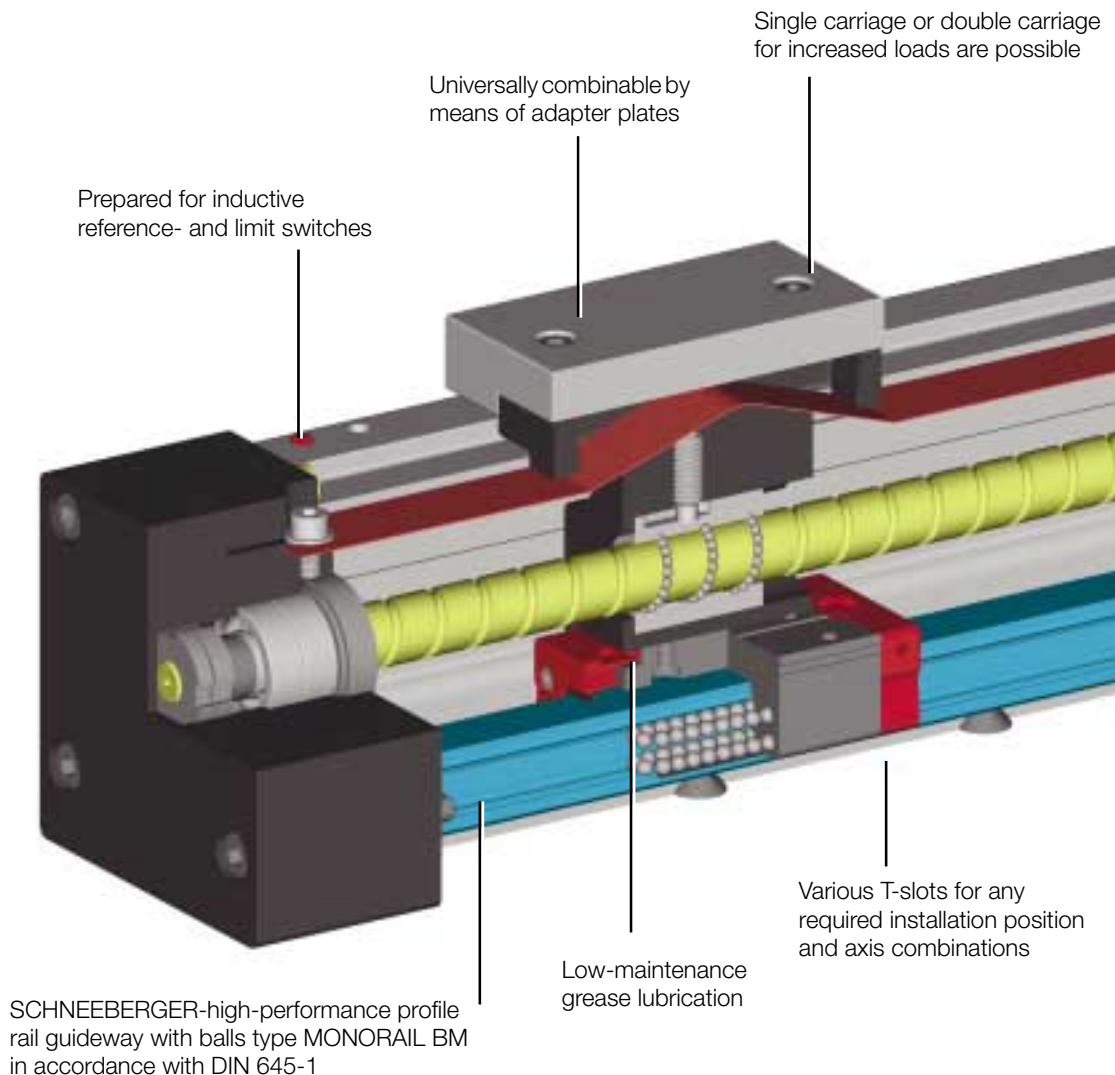
The rigid aluminum profile with recessed grooves enables a simple fixing of the module in any position by means of sliding blocks.

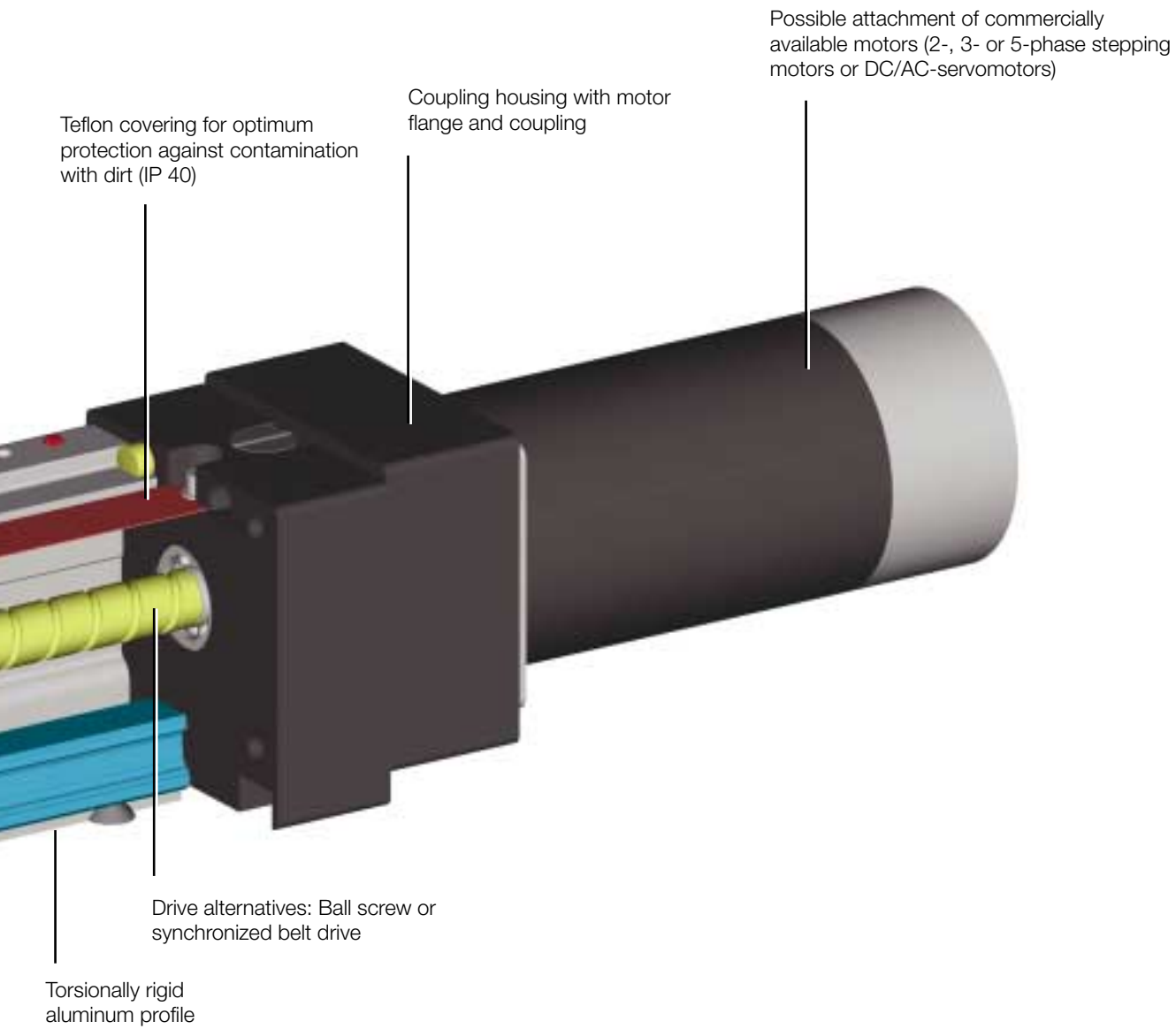
The use of ball screw drives or synchronous belts enables both precise as well as rapid movement tasks.

The linear module corresponds to the protection class IP 40. The standard Teflon covering supplied effectively protects against contamination with dirt and therefore enables a long service lifetime even under dirty ambient conditions.

For a low-maintenance operation, the profile rail guideway is factory equipped with grease lubrication. In case of highly dynamic applications, a re-greasing connection for the guideway is available as an option. The basic element is supplied as a standard version with the table plate type AP-70-01-TH. Basic and adapter plates as well as other accessories, such as sliding blocks, limit and reference switches, motors and control systems have to be ordered separately.

Figure 1:
Sectional view
Linear module ALM 70-S

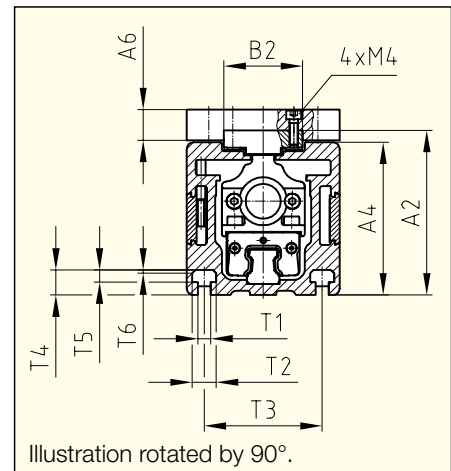




4.1.1 Dimension Table
Type ALM 70-O without Drive

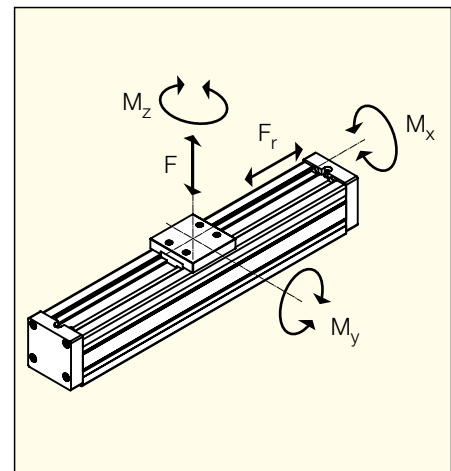


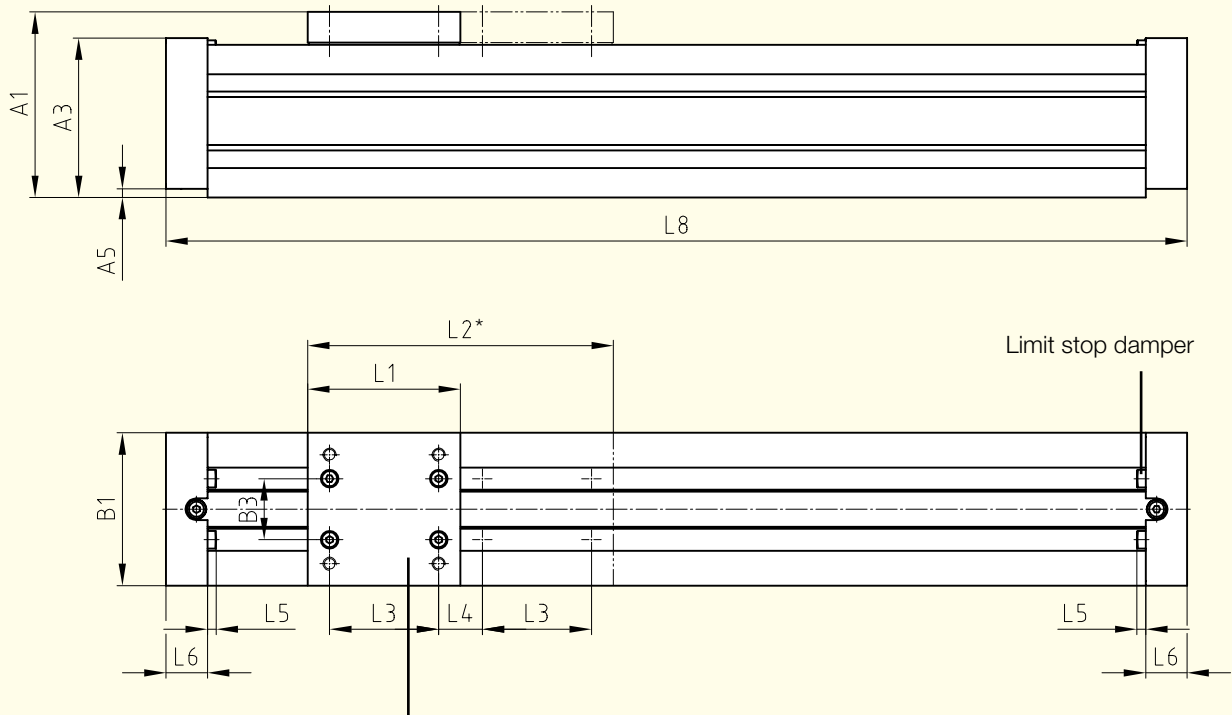
Figure 2: Linear module ALM 70-O-1



Technical Data

		ALM 70-O	
		Single carriage	Double carriage
Maximum admissible central force F	(N)	500	1 000
Dyn. Load bearing value C of the linear guideway	(N)	9 000	18 000
Admissible bending moment in case of full support	M_x (Nm)	20	40
	M_y (Nm)	30	120
	M_z (Nm)	20	68
Break-away force F_r (with 1 carriage)	(N)	6	6
Profile support recommended as from	(mm)	500	500
Maximum stroke	(mm)	2 510	2 440
Installation position		any	any
Maximum travelling speed v_{max}	(m/s)	5	5





Standard table plate AP-70-01-TH:
Bore pattern, also for double table plate AP-70-04-TH,
refer to chapter 4.3 Accessories

* optionally: Double carriage

Standard stroke (mm)	Single carriage	110	160	210	260	310	410	510	610	810	1010	1210	1410
	Double carriage	40	90	140	190	240	340	440	540	740	940	1140	1340
Overall length	L8 (mm)	252	302	352	402	452	552	652	752	962	1152	1352	1552
Weight without table plate (kg)	Single carriage	2.3	2.6	2.9	3.2	3.5	4.1	4.7	5.3	6.5	7.7	8.9	10.1
	Double carriage	2.8	3.1	3.4	3.7	4.0	4.6	5.2	5.8	7.0	8.2	9.4	10.6

Special- and intermediate strokes available on request!

A1	A2	A3	A4	A5	A6	L1	L2	L3	L4	L5	L6
85	75.5	73	70	4	14	70	140	50	20	4	19

B1	B2	B3	T1	T2	T3	T4	T5	T6
70	36	28	6	11	54	11.5	5.5	1.5×45°

All dimensions in mm. Subject to dimensional- and design modifications!

**4.1.2 Dimension Table
Type ALM 70-S with
Spindle Drive**

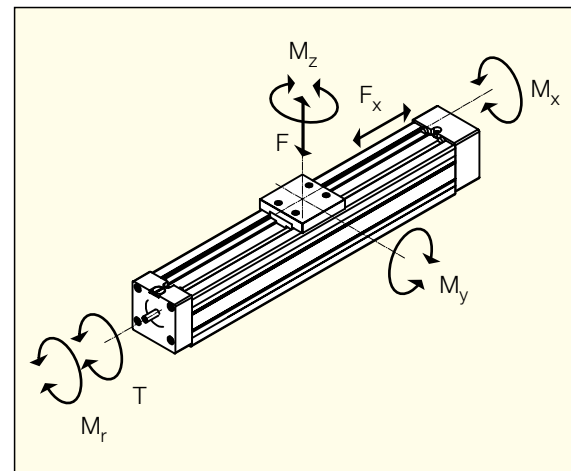
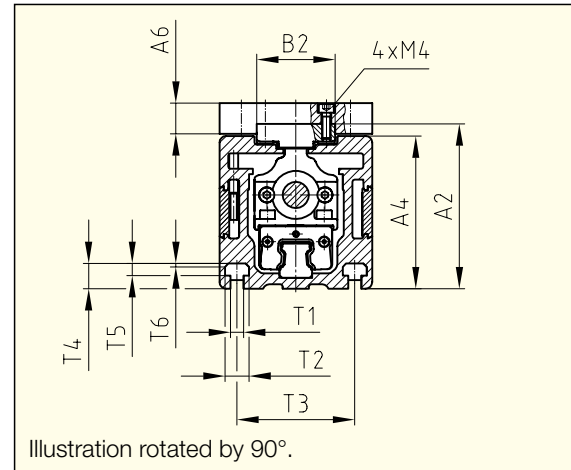
Figure 3: Linear module ALM 70-S-1-M

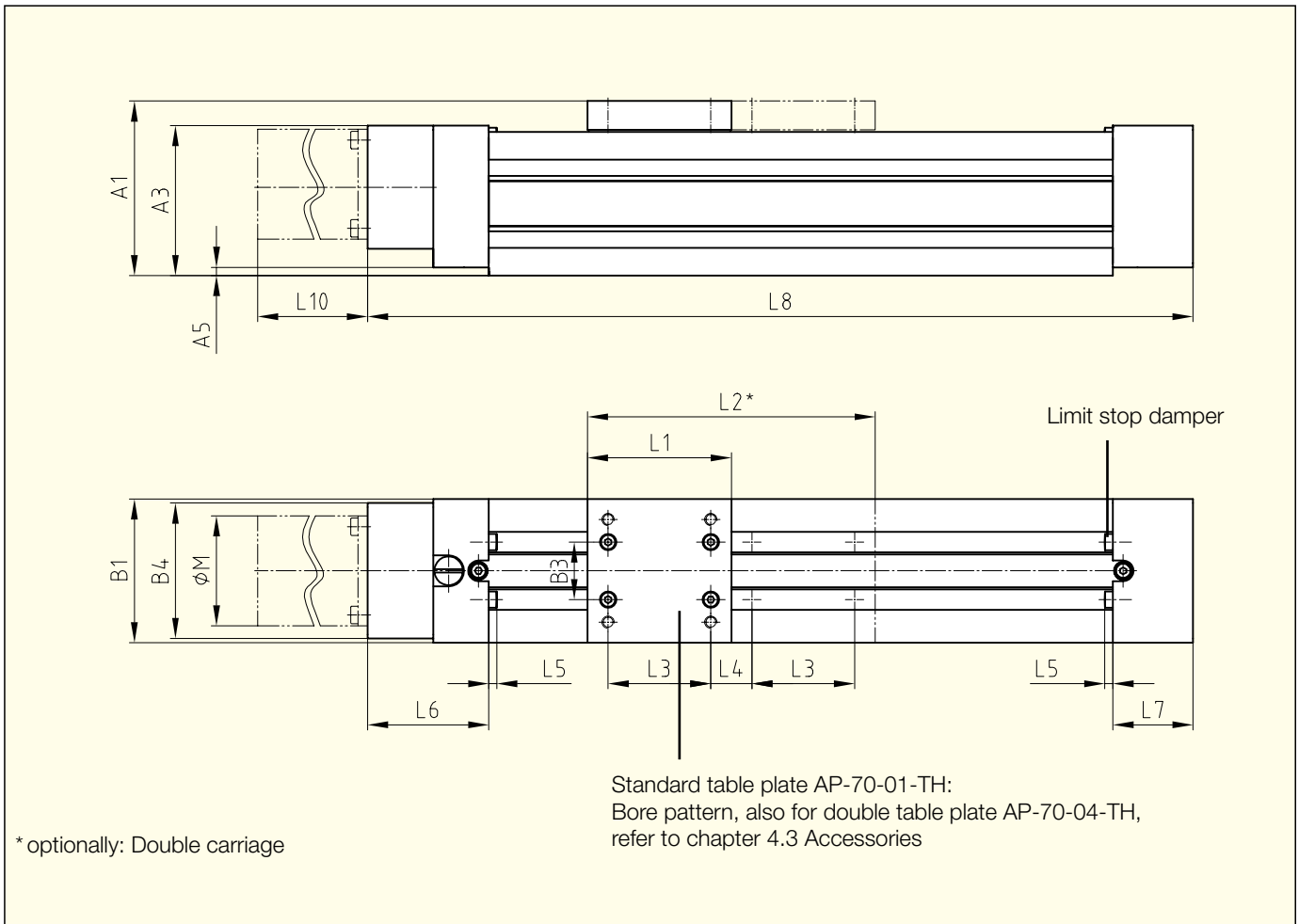


Technical Data

		ALM 70-S	
		Single carriage	Double carriage
Maximum permissible central force F	(N)	500	1 000
Dyn. Load bearing value C of the linear guideway	(N)	9 000	18 000
Permissible bending moment with full support	M_x	(Nm) 20	40
	M_y	(Nm) 30	120
	M_z	(Nm) 20	68
Max. permissible axial force F_x of the spindle	(N)	500	500
Max. recommended load to be moved at the highest dynamism	(N)	50	50
Static friction moment M_f (with 1 carriage)	(Ncm)	3	3
Profile support recommended as from	(mm)	500	500
Maximum stroke	(mm)	810	740
Installation position		any	any
Positioning accuracy*	(mm/m)	$\pm 0.05/0.3$	$\pm 0.05/0.3$
Repeatability*	(mm)	ca. ± 0.02	ca. ± 0.02
Lead error of the ball screw K12x10: G50 (IT7)	(mm/mm)	0.05/300	0.05/300
Feed per motor revolution without gearing	(mm)	10	10
Maximum travelling speed v_{max}	(m/s)	0.3	0.3
Maximum motor shaft diameter	(mm)	14	14
Maximum drive torque T	(Nm)	4	4

* Dependent on the type of motor





Standard stroke (mm)	Single carriage	110	160	210	260	310	410	510	610	810
	Double carriage	40	90	140	190	240	340	440	540	740
Overall length	L8 (mm)	312	362	412	462	512	612	712	812	1012
Weight without table plate and motor (kg)	Single carriage	3.0	3.3	3.6	3.9	4.3	4.9	5.5	6.2	7.5
	Double carriage	3.5	3.8	4.1	4.4	4.8	5.4	6.0	6.7	8.0

Special- and intermediate strokes available on request!

A1	A2	A3	A4	A5	A6	L1	L2	L3	L4	L5	L6	L7	L10
85	75.5	73	70	4	14	70	140	50	20	4	59	39	*

∅M	B1	B2	B3	B4	T1	T2	T3	T4	T5	T6
*	70	36	28	66	6	11	54	11.5	5.5	1.5×45°

* Dependent on the type of motor
All dimensions in mm. Subject to dimensional- and design modifications!

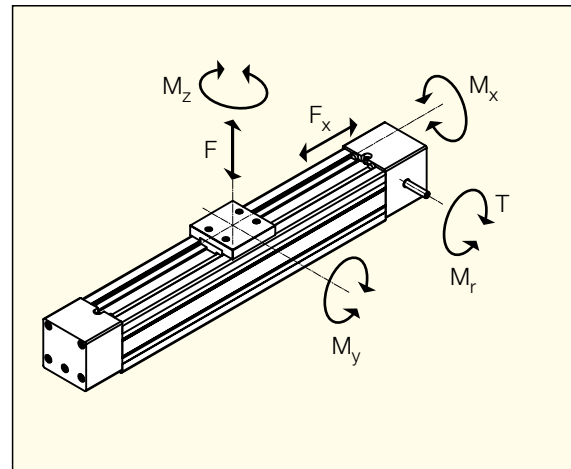
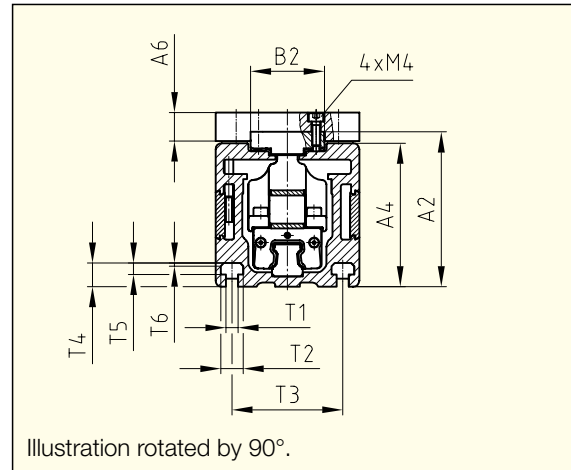
**4.1.3 Dimension Table Type
ALM 70-B with Belt Drive**



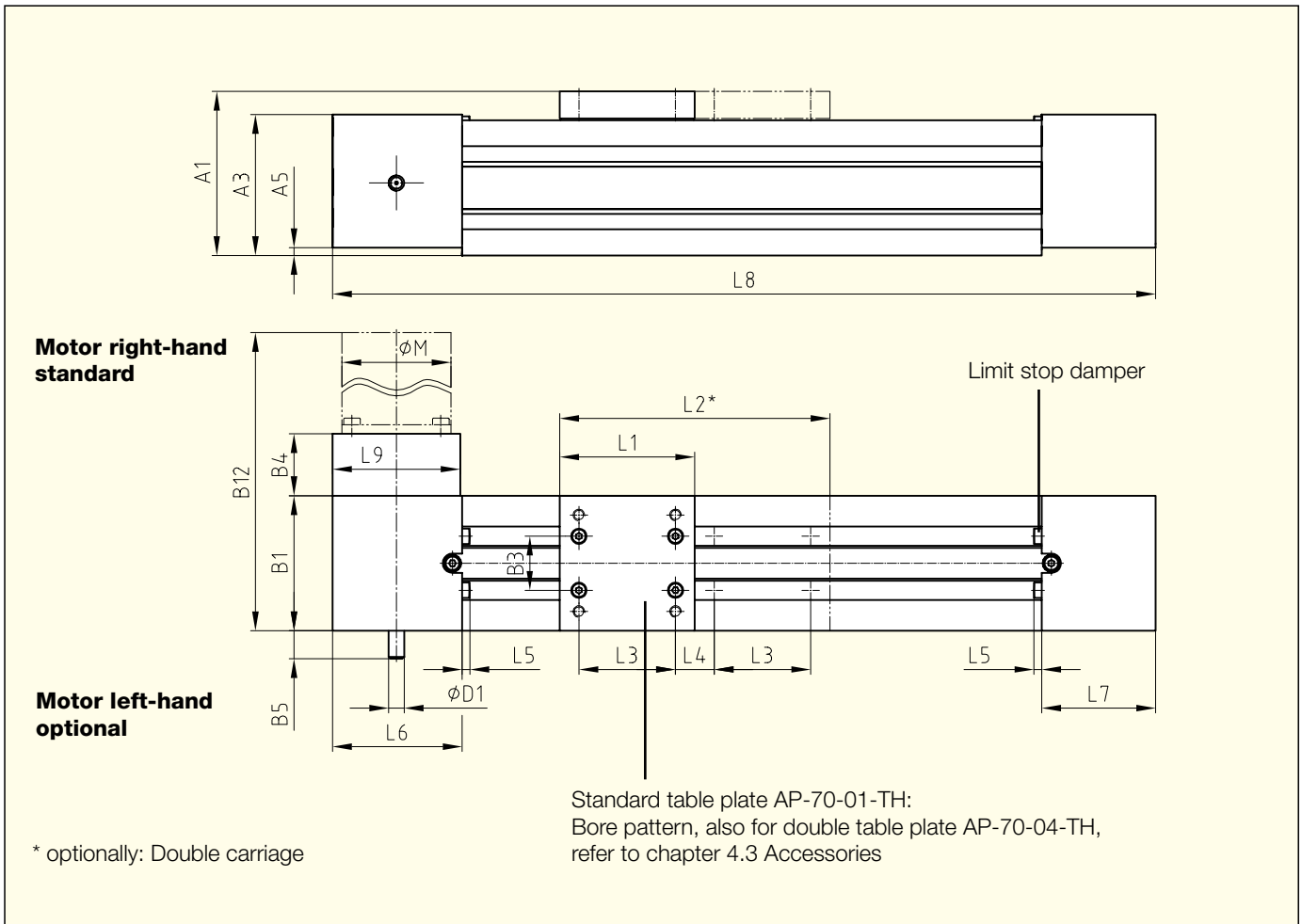
Figure 4: Linear module ALM 70-B-1-M-R

Technical Data

		ALM 70-B	
		Single carriage	Double carriage
Maximum permissible central force F	(N)	500	1 000
Dyn. Load bearing value C of the linear guideway	(N)	9 000	18 000
Permissible bending moment with full support	M_x	(Nm) 20	40
	M_y	(Nm) 30	120
	M_z	(Nm) 20	68
Max. permissible tensile force F_x of the belt	(N)	500	500
Max. recommended load to be moved at high dynamism	(N)	50	50
Static friction moment M_r (with 1 carriage)	(Ncm)	6.6	6.6
Profile support recommended as from	(mm)	500	500
Maximum stroke	(mm)	2 510	2 440
Installation position		any	any
Positioning accuracy*	(mm/m)	$\pm 0.15/0.3$	$\pm 0.15/0.3$
Repeatability*	(mm)	ca. ± 0.03	ca. ± 0.03
Feed per motor revolution without gearing	(mm)	50	50
Maximum travelling speed v_{max}	(m/s)	1.5	1.5
Maximum motor shaft diameter	(mm)	14	14
Maximum drive torque T	(Nm)	3	3



* Dependent on the type of motor



Standard stroke (mm)	Single carriage	110	160	210	260	310	410	510	610	810	1010	1210	1410
	Double carriage	40	90	140	190	240	340	440	540	740	940	1140	1340
Overall length	L8 (mm)	340	390	440	490	540	640	740	840	1040	1240	1440	1640
Weight without table plate and motor (kg)	Single carriage	3.5	3.8	4.1	4.4	4.7	5.3	5.9	6.5	7.7	8.9	10.2	11.4
	Double carriage	4.0	4.3	4.6	4.9	5.2	5.8	6.4	7.0	8.2	9.4	10.7	11.9

Special- and intermediate strokes available on request!

A1	A2	A3	A4	A5	A6	L1	L2	L3	L4	L5	L6	L7	L9
85	75.5	73	70	4	14	70	140	50	20	4	67	59	66

ØM	B1	B2	B3	B4	B5	B12	D1	T1	T2	T3	T4	T5	T6
*	70	36	28	32	15	*	8 h 7	6	11	54	11.5	5.5	1.5×45°

* Dependent on the type of motor
All dimensions in mm. Subject to dimensional- and design modifications!

4.2 Product Characteristics ALM 80

The high-performance module for universal utilization.

The optimized, torsionally rigid aluminum profile makes space- and cost-saving individual axes possible even in the case of high tilting torques. The built-in SCHNEEBERGER profile rail guideways type MONORAIL BM 20 ensure a high guiding accuracy.

Special adapter plates also permit the combination with other sizes and types.

The belt drive enables highly dynamic travelling tasks with a maximum speed of $v_{max} = 3.5 \text{ m/s}$!

The highly rigid aluminum profile with recessed slots makes possible a simple fixing of the module by means of sliding blocks in any position.

The internal space is protected against contamination with dirt by the belt. Thus even under dusty operating conditions, a long service lifetime is achieved.

For a low-maintenance operation, the profile rail guideway is factory equipped with

grease lubrication. Re-greasing takes place through the central grease nipple.

The basic element is supplied as standard version with table plate. Base and adapter plates as well as other accessories, such as sliding blocks, limit and reference switches, motors and control systems have to be ordered separately.

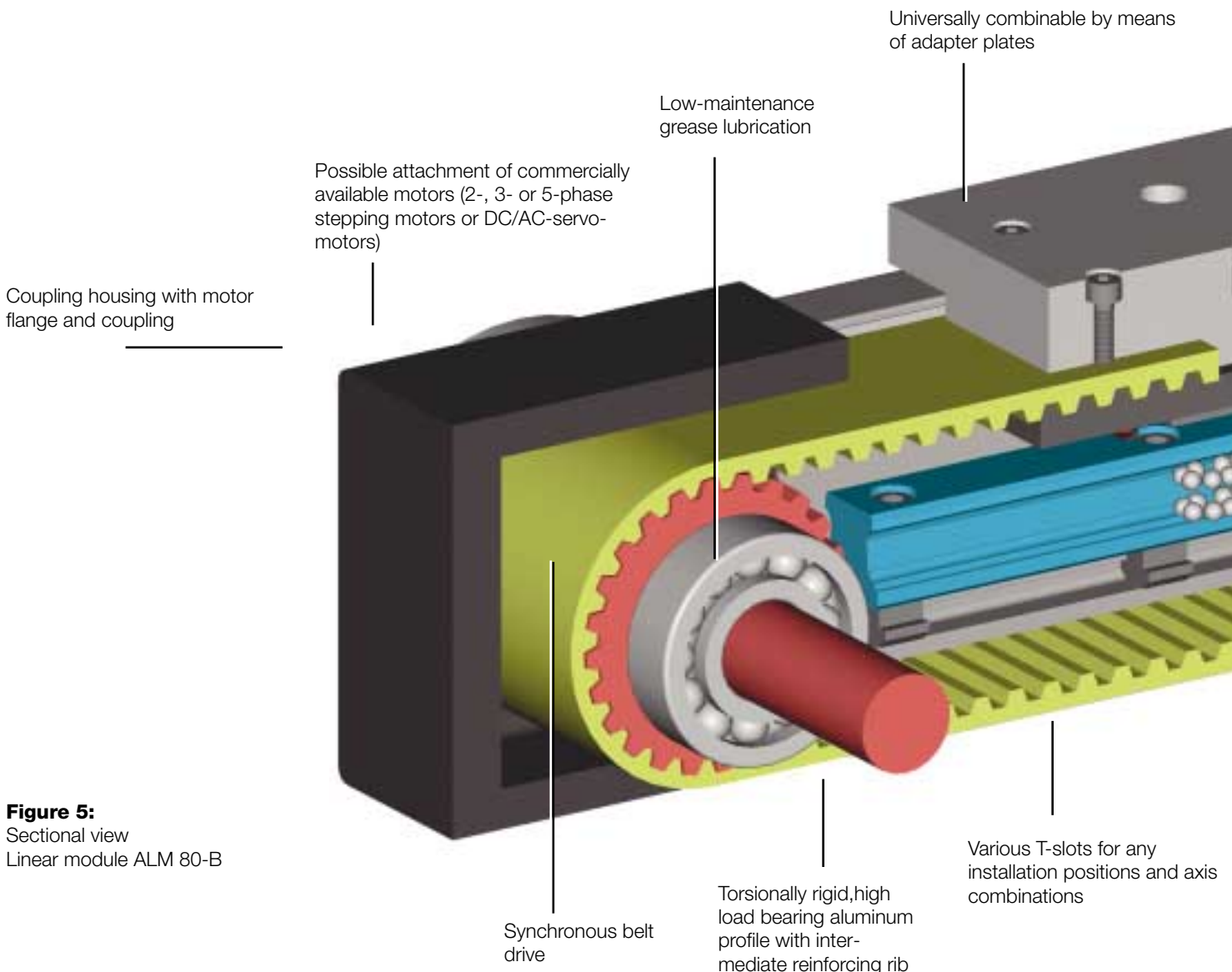
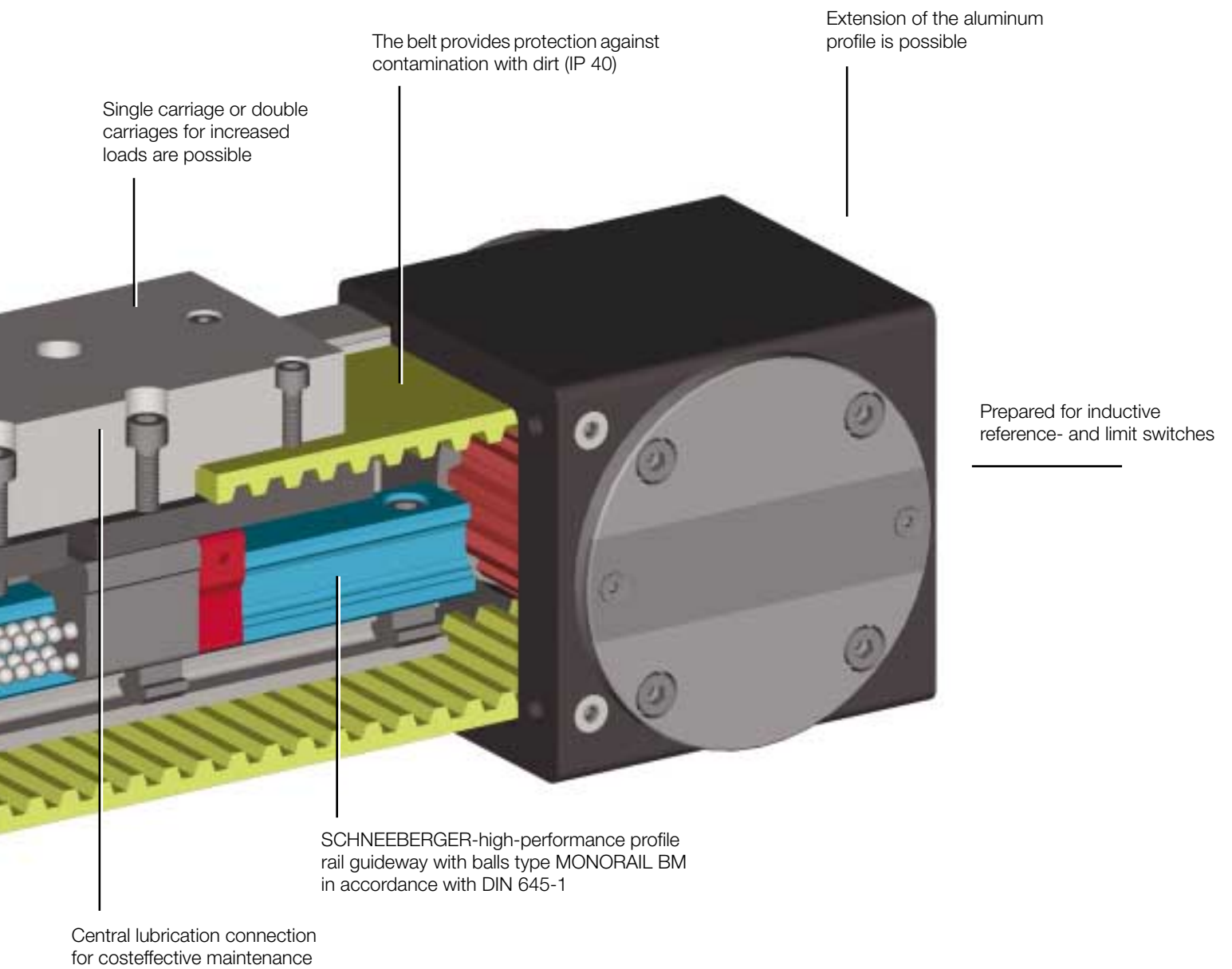
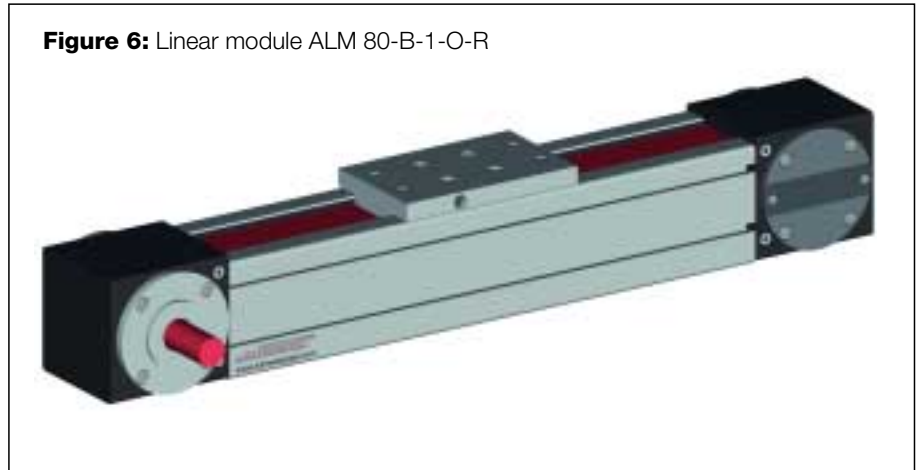


Figure 5:
Sectional view
Linear module ALM 80-B



**4.2.1 Dimension Table
Type ALM 80-B with
Belt Drive**

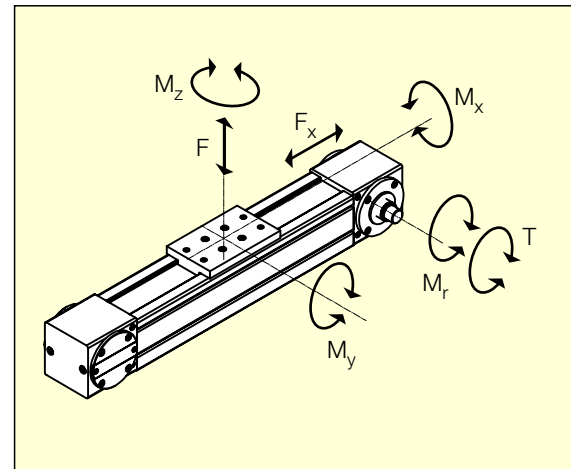
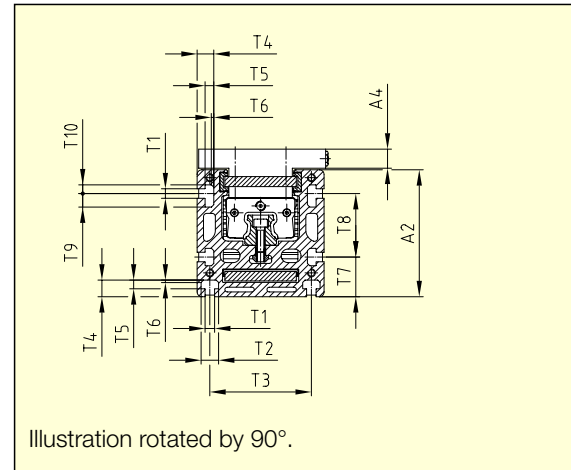
Figure 6: Linear module ALM 80-B-1-O-R



Technical Data

		ALM 80-B	
		Single carriage	Double carriage
Maximum permissible central force F	(N)	1600	3200
Dyn. load bearing value C of the linear guideway	(N)	14400	28800
Permissible bending moment with full support	M_x (Nm)	72	144
	M_y (Nm)	42	210
	M_z (Nm)	36	144
Max. permissible tensile force F_x of the belt	(N)	1300	1300
Max. recommended load to be moved with high dynamism	(N)	800	800
Static friction moment M_f (with 1 carriage)	(Ncm)	80	80
Profile support recommended as from	(mm)	1000	1000
Max. stroke	One-part (mm)	6740	6652
	Multi-part (mm)	12000	11912
Installation position		any	any
Positioning accuracy*	(mm/m)	$\pm 0.3/0.3$	$\pm 0.3/0.3$
Repeatability*	(mm)	$\pm 0.05/1000$	$\pm 0.05/1000$
Feed per motor revolution without gearing	(mm)	192	192
Maximum travelling speed v_{max}	with load 30 kg (m/s)	3.5	3.5
	with load 80 kg (m/s)	1.5	1.5
Maximum diameter of drive shaft	(mm)	20	20
Maximum drive torque T	(Nm)	75	75

* Dependent on the type of motor



4.3 Accessories – to be ordered separately

2nd carriage (double carriage) DW

For achieving a much higher torque, load bearing capacity and for doubling the load bearing capacity, a second carriage can be added.

ALM 70:

- As standard version, the table plate AP-70-04-TH is mounted. Bore pattern, see page 28, figure 12.
- The available stroke is reduced by 70 mm.

ALM 80:

- The carriage is elongated correspondingly. Bore pattern refer to chapter 4.2.1
- The available stroke is reduced by 88 mm.

Adapter plate AP

For the universal fixing of the modules, various adapter plates are available. The scope of supply also includes corresponding screws, resp., sliding blocks. Illustrations, see page 28, figures 7ff.

Reference and limit switch PNP

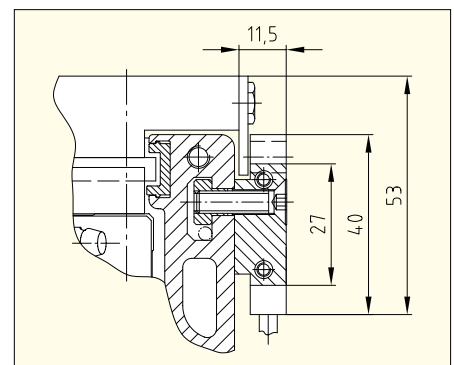
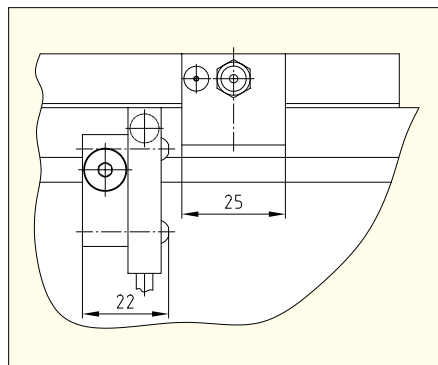
The inductive switches are available both as PNP normally closed and PNP normally open versions (10 ... 30 V). The free cable length is approx. 2m.

ALM 70:

- Integrated into the module
- Two positions selectable per side

ALM 80:

- Affixed to the outside; put into action by lever mounted on the carriage
- Adjustable in the fixing slot of the aluminum profile



Lubrication connection SS

Only available as an option for ALM 70; Standard for ALM 80

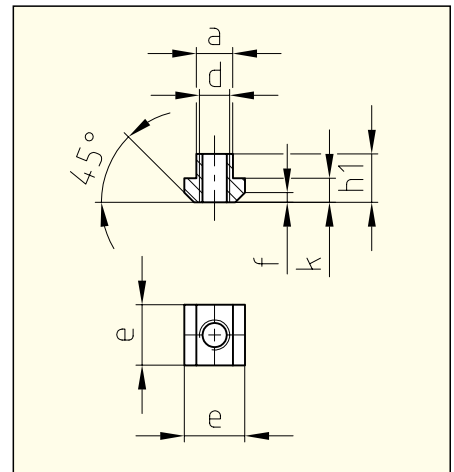
Connection of 2 linear modules each AV

SCHNEEBERGER takes over the installation and alignment of 2 connected linear modules; corresponding adapter plates have to be ordered separately.

Sliding block NS

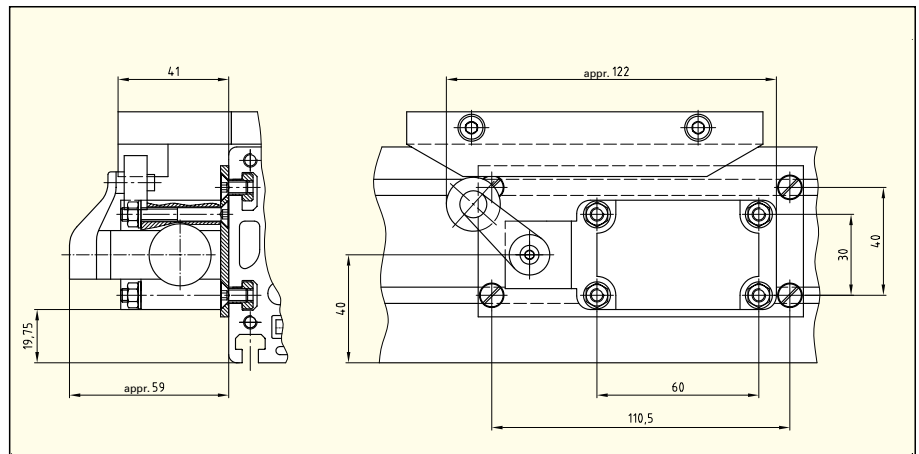
The sliding blocks correspond to DIN 508 M5x6 and are corrosion-resistant.

a	d	e	f	h1	k
6	M5	10	1.6	8	4



Limit switch special mounting outside LS

On request, special limit switches can be attached to the outside of the aluminum profile.
ALM 70: Inductive switch
ALM 80: Mechanical switch



Fixed stop per side ML

In order to avoid damage following collisions, e. g. within a portal superstructure, mechanical limit stops made of aluminum are available.

Coupling CP

Corresponding to the selected motor, a suitable coupling has to be chosen.

Motor flange MF

The motor flange serves to adapt the motor to the coupling housing.

Motor mounting in case of ball screw drive on the right-hand side MS

By means of the parallel attachment of the motor in case of the ALM 70 with ball screw drive, a reduction of the installation space can be achieved. On request!

Centre drive (in case of ball screw drive) MD

On request!

Universal jointed shaft (in case of belt drive) CW

On request!

Adapter plates for ALM 70

Further bores, e.g., for the adaptation of other components, can easily be made in the material by the customer himself.

Figure 7: Adapter plate AP-70-01

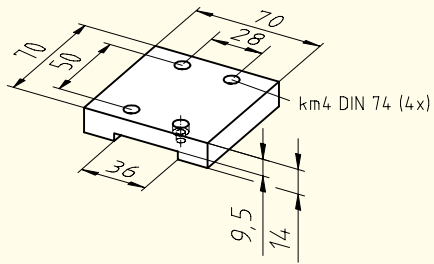


Figure 8: Adapter plate AP-70-01-TH

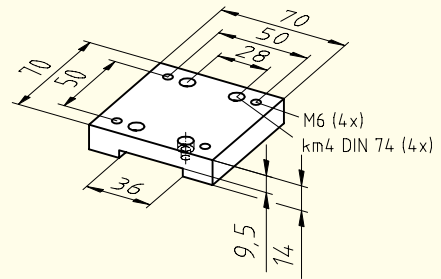


Figure 9: Adapter plate AP-70-02

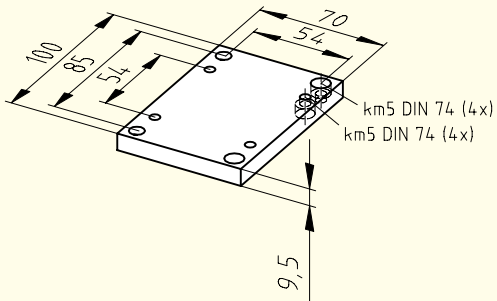


Figure 10: Adapter plate AP-70-03

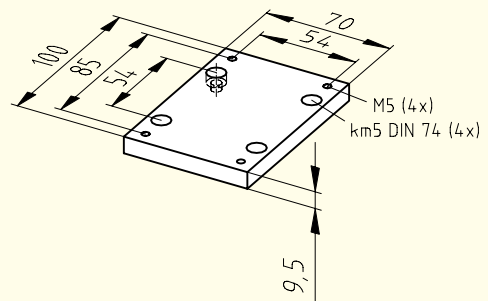


Figure 11: Adapter plate AP-70-04

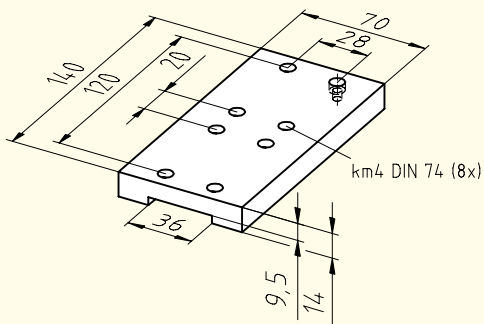


Figure 12: Adapter plate AP-70-04-TH

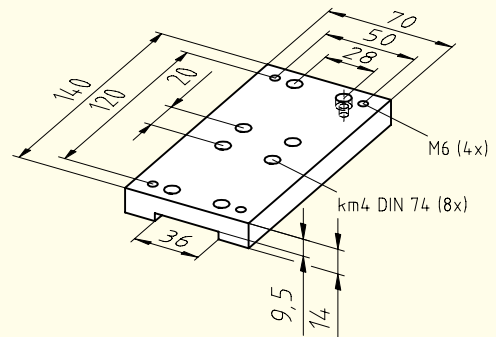


Figure 13: Adapter plate AP-70-05

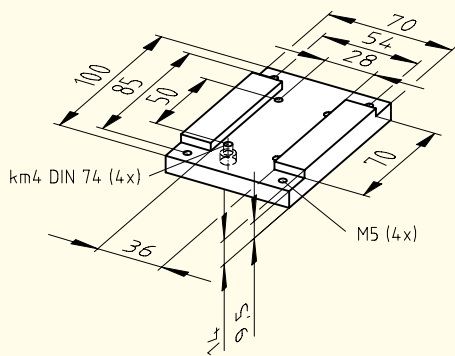


Figure 14: Adapter plate AP-70-06

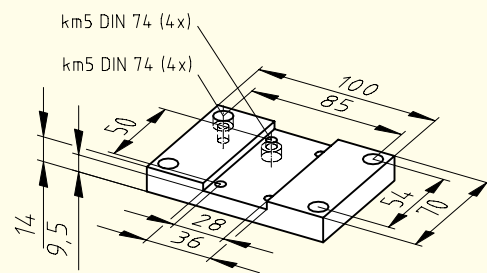


Figure 15: Adapter plate AP-70-07

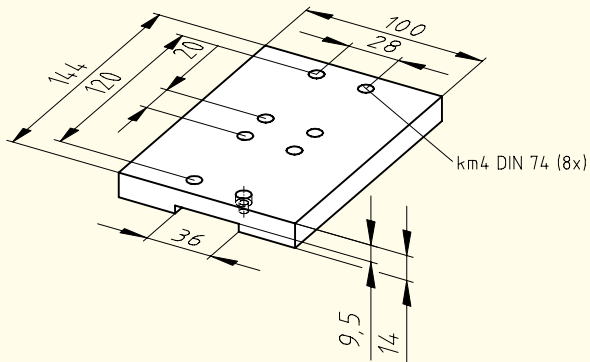


Figure 16: Adapter plate AP-70-08

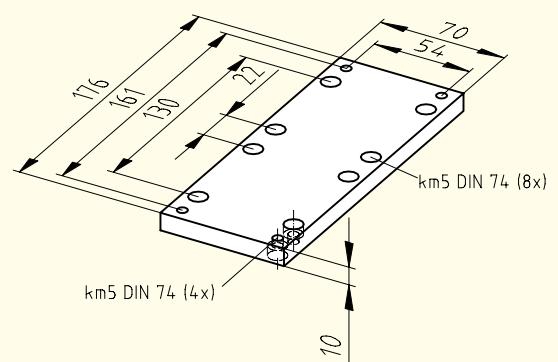


Figure 17: Adapter plate AP-70-09

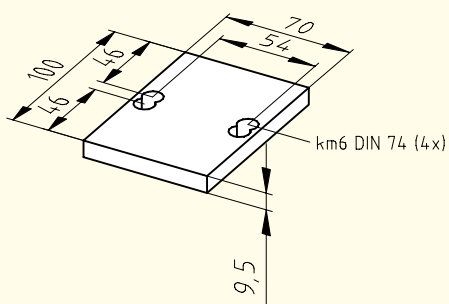


Figure 18: Adapter plate AP-70-10

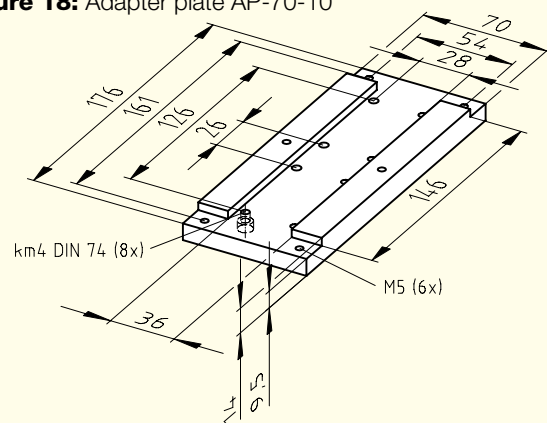


Figure 19: Adapter plate AP-70-11

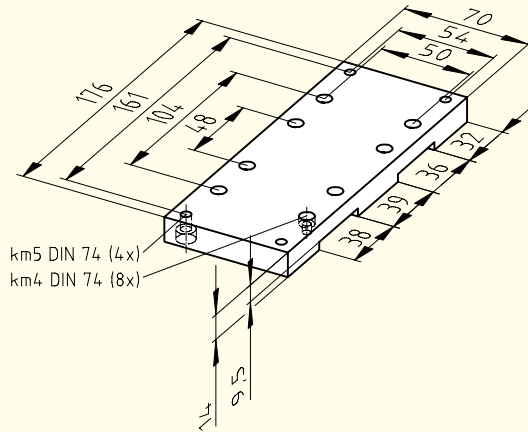


Figure 20: Adapter plate AP-70-12

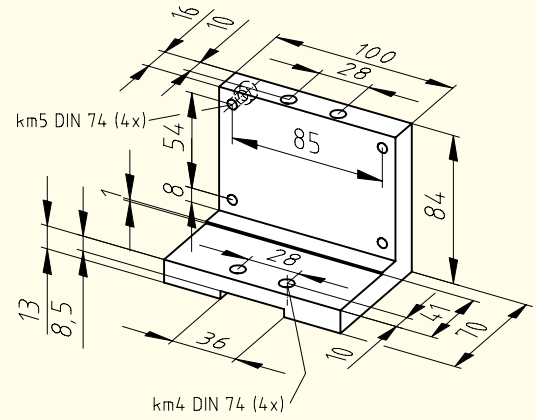


Figure 21:
Adapter plate AP-70-13

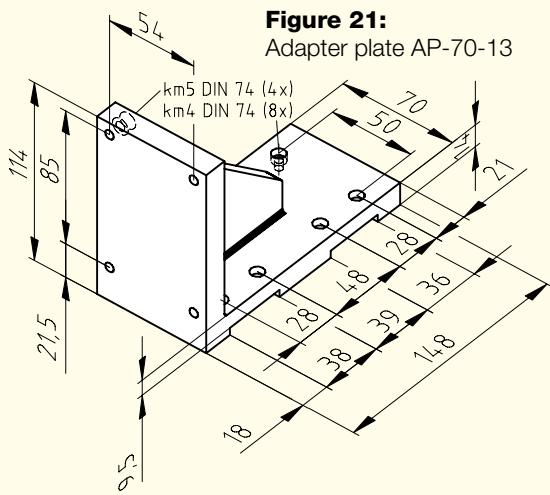
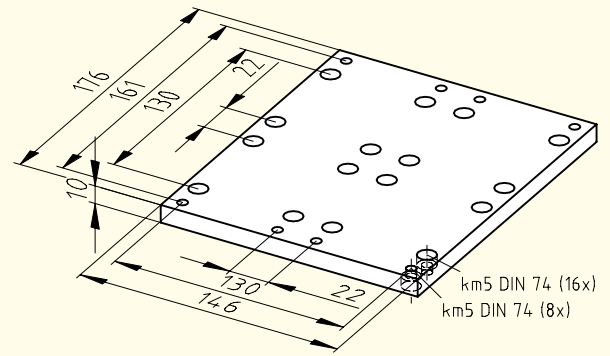


Figure 22: Adapter plate AP-70-14



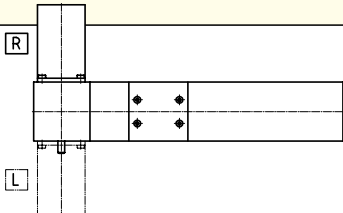
Adapter plates for ALM 80

Additional adapter plates will be designed specially according to the application.

4.4 Ordering Information

Linear module ALM

		—	ALM	70	-0740	-S	-2	-O	-R
Quantity									
Type	ALM								
Size	70, 80								
Stroke in mm									
Type of drive	O Without drive (only 70) S Ball screw drive (only 70) B Belt drive								
Number of carriages	1 Single carriage 2 Double carriages								
Motor	O Without motor or -adapter M With motor adapter or motor mounting (to be specified separately)								
Motor position (only in case of belt drive)	R Motor/drive right-hand (standard) L Motor/drive left-hand								



Accessories linear module ALM – to be ordered separately

2nd carriage (double carriage)

		—	DW	-70
Quantity				
Designation	DW			
Size	70, 80			

Adapter plate for ALM 70

		—	AP	-70	-01
Quantity					
Designation	AP				
Size	70				
Type	01, 01-TH*, 02, 03, 04, 04-TH, 05, 06, 07, 08, 09, 10, 11, 12, 13, 14				

* Mounted as standard version; other versions have to be ordered separately

Reference- / limit switch

		—	PNP	-O	-70
Quantity					
Designation	PNP				
Type	O Normally closed S Normally open				
Size	70, 80				

Sliding block

		—	NS	-M5
Quantity				
Designation	NS			
Type	M5 Standard version for both types			

Lubrication connection (only ALM 70)

		—	SS	-70
Quantity				
Designation	SS			
Size	70			

Connection of 2 linear modules each*

		—	AV	-70
Quantity				
Designation	AV			
Size	70, 80			

* Installation including the alignment of 2 linear modules, adapter plates are not part of the scope of supply

Limit switch special mounting outside

		—	LS	-E	-80
Quantity					
Designation	LS				
Type	E				
Size	70, 80				

Fixed stop per side

		—	ML	-70
Quantity				
Designation	ML			
Size	70, 80			

Coupling

			—	CP	-70	-S
Quantity						
Designation	CP					
Size	70, 80					
Type	S	Special version (the motor has to be specified)				

Motor flange

			—	MF	-70	-S
Quantity						
Designation	MF					
Size	70, 80					
Version	S	Special version (the motor has to be specified)				

Motor mounting in case of ball screw drive on the right-hand side (only ALM 70)

			—	MS	-70	
Quantity						
Designation	MS					
Size	70					

Center drive in case of ball screw drive* (only ALM 70)

			—	MD	-70	-500
Quantity						
Designation	MD					
Size	70					
Center distance of the axes in mm						

* without coupling, flange and installation

Universally jointed shaft in case of belt drive

			—	CW	-70	-500	-S
Quantity							
Designation	CW						
Size	70, 80						
Centre distance of the axes in mm							
Version	S	Single					
	D	Double (split and supported shaft; motor is located between the shafts)					

5.1 Product Characteristics ALS 140

The linear module ALS 140 is a precise, ready to install module with high performance characteristics with respect to the stability and to the exceptionally compact construction.

The fulfilment of these exceedingly important characteristics is assured by the rigid aluminum profile in conjunction with hardened steel shafts and precision linear ball bearings.

This linear module can be driven with a synchronous belt, ball screw or a pneumatic cylinder.

The ball screw drive with a low backlash nut makes high positioning accuracy and repeatability possible.

For extremely fast handling and positioning tasks, the synchronous belt or pneumatic drive is recommended.

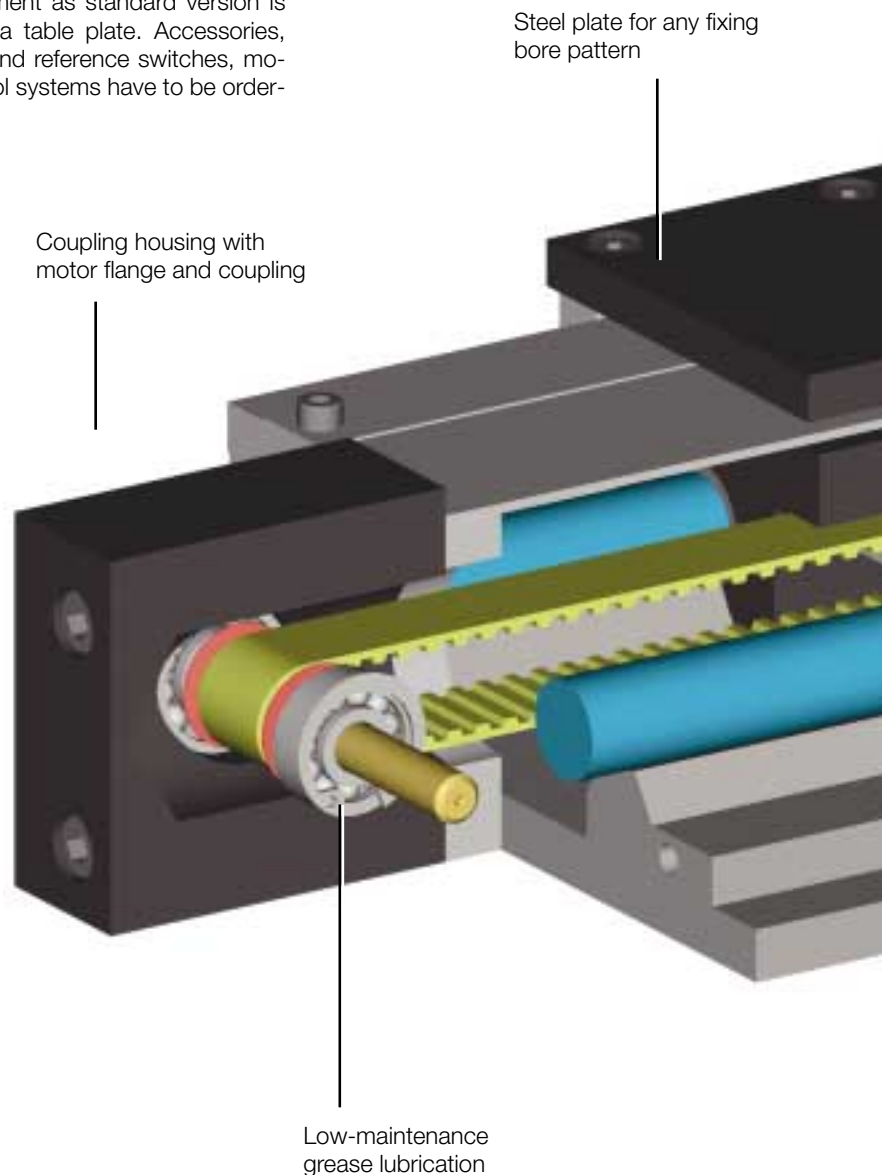
The standard U-shaped sheet metal covering protects the built-in elements and enables full use of the maximum stroke compared to units with conventional bellows coverings.

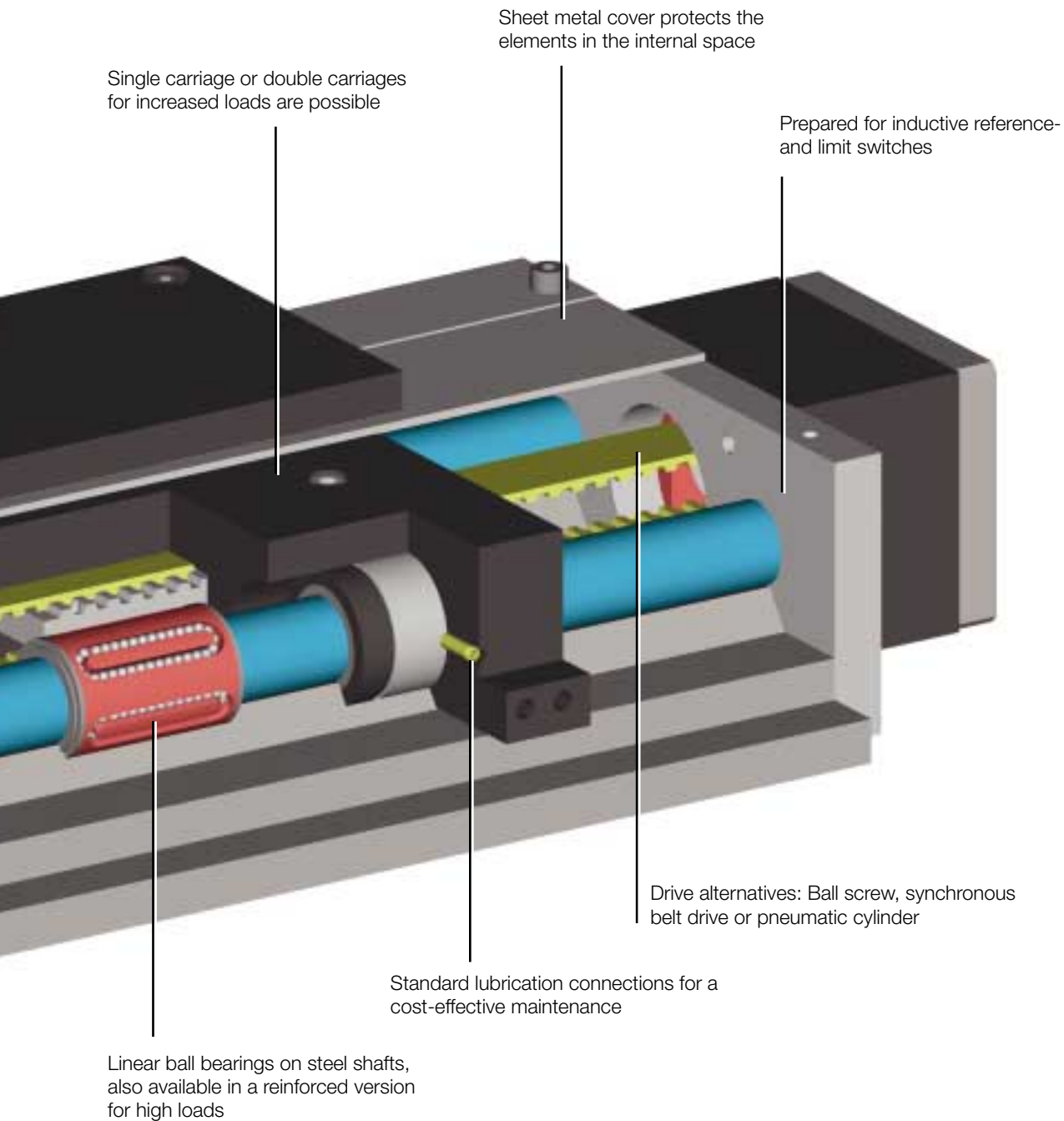
The prepared lubrication equipment makes cost-effective maintenance possible and also assures a long service lifetime.

The basic element as standard version is supplied with a table plate. Accessories, such as limit and reference switches, motors and control systems have to be ordered separately.

Figure 1:
Sectional view
Linear module ALS 140-B

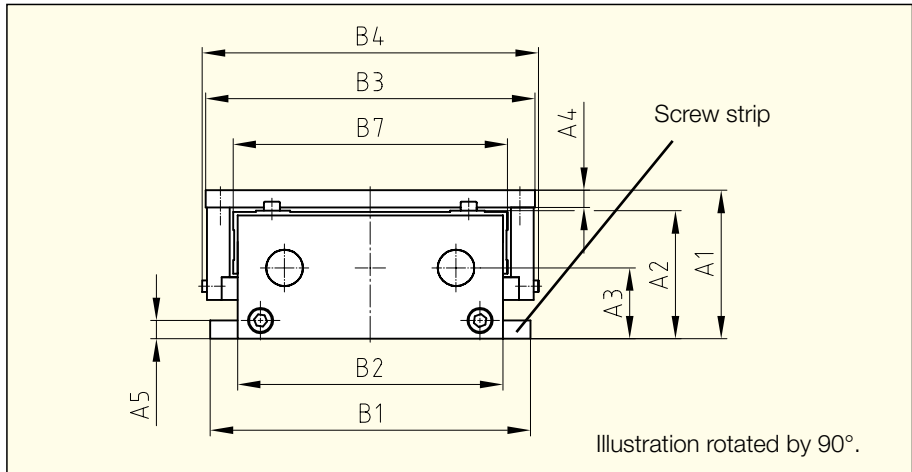
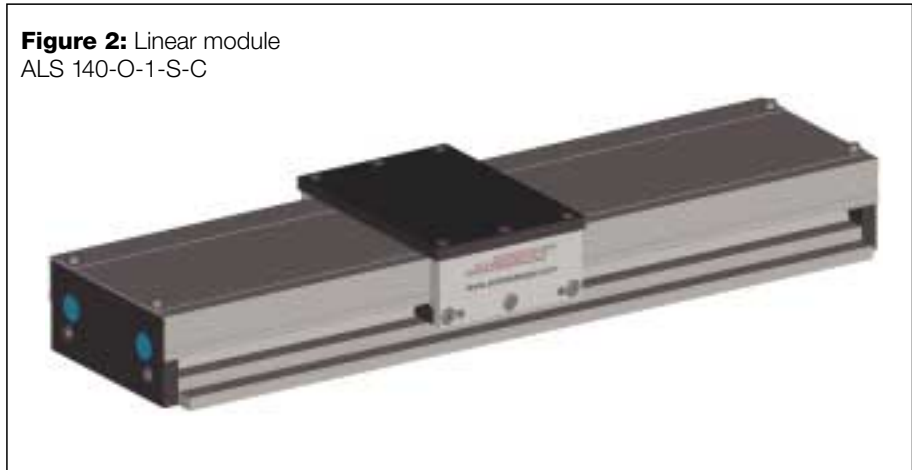
Possible attachment of commercially available motors (2-, 3-, or 5-phase stepping motors or DC/AC-servomotors)





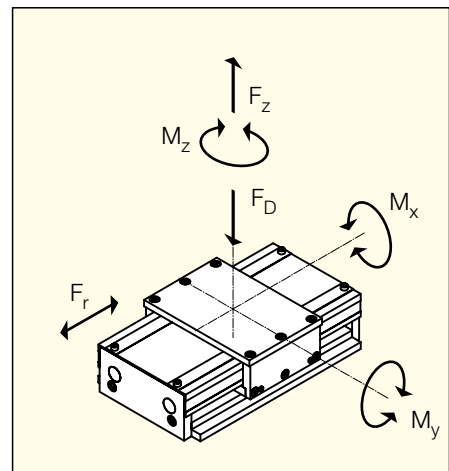
5.1.1 Dimension Table
Type ALS 140-O without Drive

Figure 2: Linear module
 ALS 140-O-1-S-C



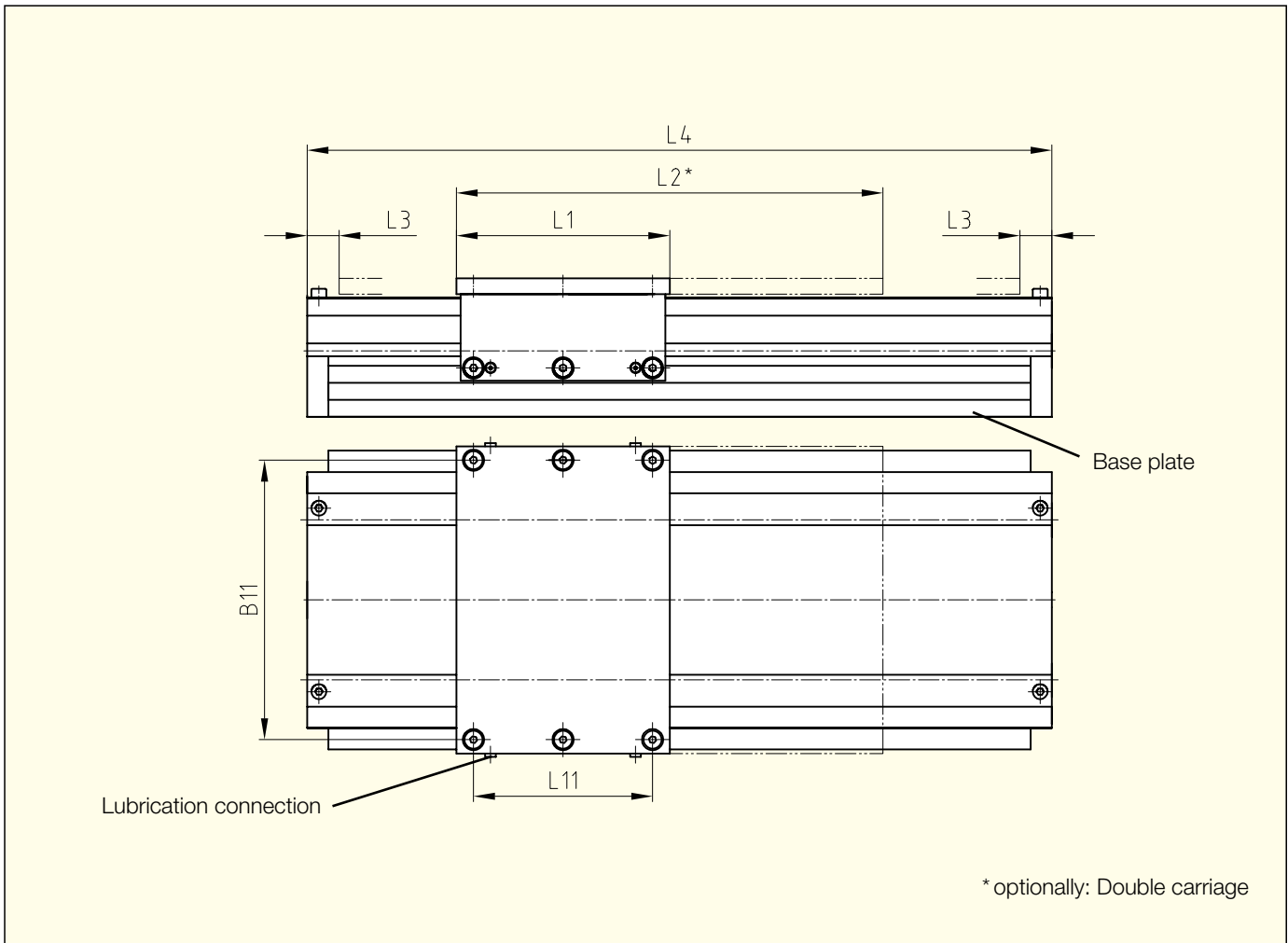
Technical data

		ALS 140-O	ALS 140-O-H
Max. permissible centr. compressive force F_b per carr. (N)		2000	4000
Max. permissible centr. tensile force F_z per carr. (N)		1300	2800
Dynamic load-bearing value C of the linear guideway* per carriage (N)		4200	8800
Permissible bending moment in case of full support		Single carr.**	Single carr.**
	M_x (Nm)	47	94
	M_y (Nm)	40	80
	M_z (Nm)	40	80
Break-away force F_r (with 1 carriage) (N)		15	15
Profile support recommended as from (mm)		500	500
Maximum stroke** (mm)		2500	2500
Installation position		any	any
Maximum travelling speed v_{max} (m/s)		5	3



* In the direction of the principal load

** Values for double carriage are dependent on the carriage spacing



Standard stroke (mm)	Single carriage	100	150	200	250	300	400	500	600	800	1000
	Double carriage	–	50	100	150	200	300	400	500	700	900
Overall length	L4 (mm)	239	289	339	389	439	539	639	739	939	1139
Weight without table plate and motor (kg)	Single carriage	4.6	5.0	5.4	5.9	6.4	7.4	8.3	9.3	11.2	13.1

Special - and intermediate strokes available on request!

A1	A2	A3	A4	A5	B1	B2	B3	B4	B7	B11	L1	L2	L3	L11
65	56	31	7.5	8	140	116	144	147	120	131	100	200	15	84

All dimensions in mm. Subject to dimensional - and design modifications!

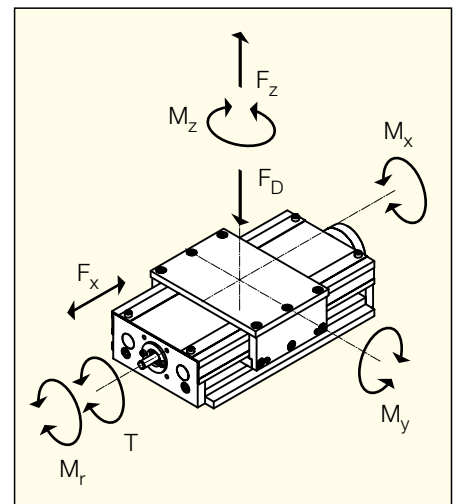
**5.1.2 Dimension Table
Type ALS 140-S
with Spindle Drive**

Figure 3: Linear module
ALS 140-S-1-S-C-K12×5-M



Technical Data

		ALS 140-S	ALS 140-S-H
Max. perm. centr. compressive force F_D per carr. (N)		2000	4000
Max. perm. centr. tensile force F_z per carr. (N)		1300	2800
Dynamic load bearing value C of the linear guideway* per carriage (N)		4200	8800
Permissible bending moment with full support		Single carr.**	Single carr.**
	M_x (Nm)	47	94
	M_y (Nm)	40	80
	M_z (Nm)	40	80
Max. perm. axial force F_x of the spindle*** (N)		400	400
Maximum recommended load to be moved in case of great dynamism (N)		400	400
Static friction moment M_r (with 1 carriage) (Ncm)		2	2
Profile support recommended as from (mm)		500	500
Maximum stroke** (mm)		1500	1500
Installation position		any	any



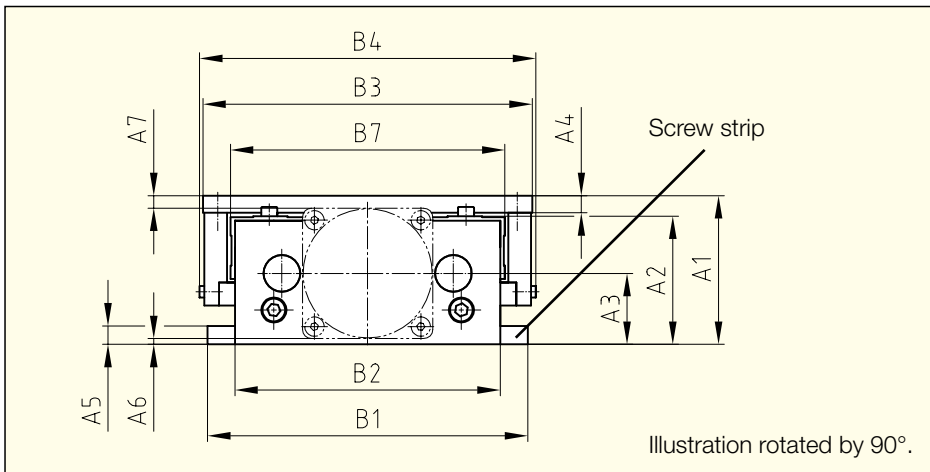
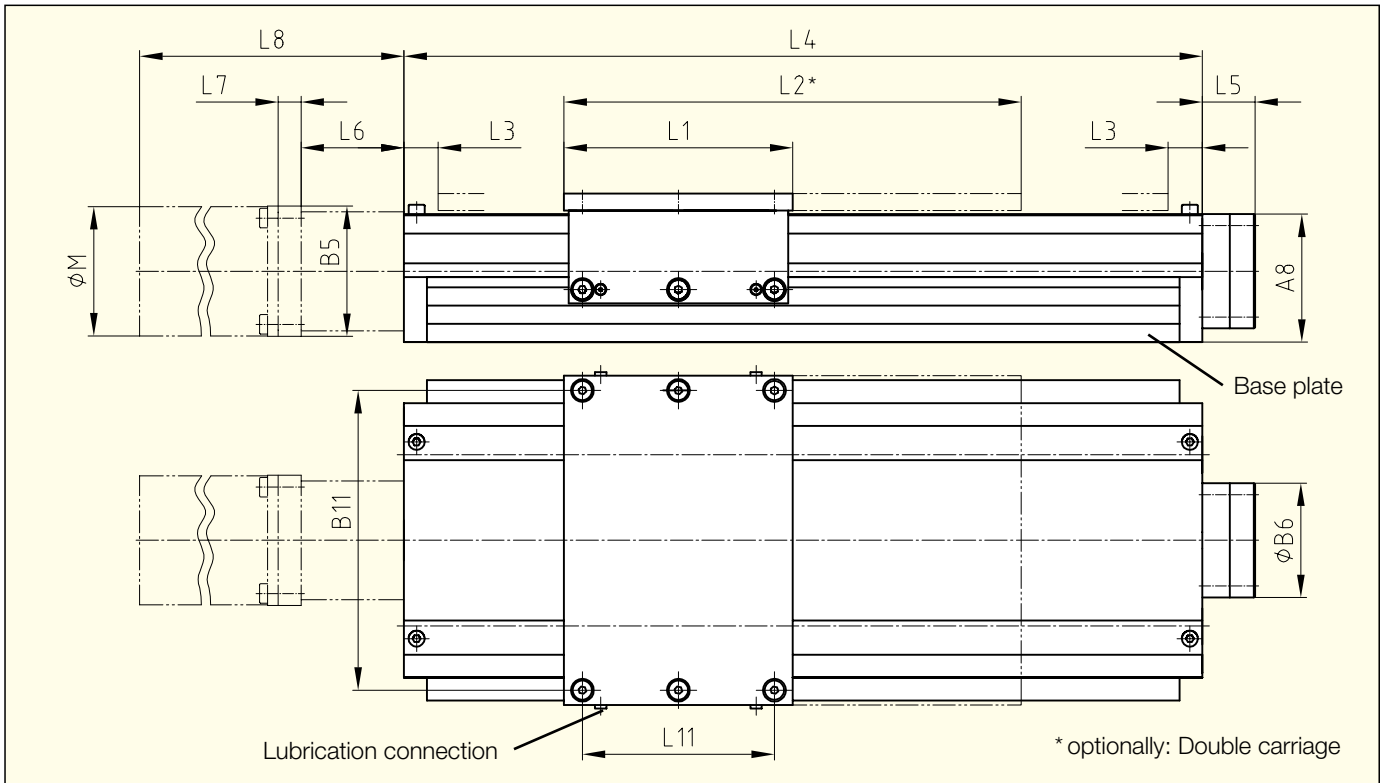
Ball screw type		K12×5	K16×10	K16×16	K16×50
Positioning accuracy**** (mm/m)		±0.05/0.3	±0.05/0.3	±0.1/0.3	±0.15/0.3
Repeatability**** (mm)		Approx. ±0.02	Approx. ±0.02	Approx. ±0.02	Approx. ±0.02
Lead error of the ballscrew: G50 (IT7) (mm/mm)		0.05/300	0.05/300	0.05/300	0.05/300
Feed per motor revolution without gearing (mm)		5	10	16	50
Max. travelling speed v_{max} (m/s)		0.2	0.3	0.5	1.0
Max. motor shaft diameter (mm)		14	14	14	14
Max. drive torque T (Nm)		4	4	4	4

* In the direction of the principal load

** Values for double carriages are dependent on the carriage spacing

*** In case of standard bearing support

**** Dependent on the type of motor and spindle



Standard stroke (mm)	Single carriage	100	150	200	250	300	400	500	600	800	1000	1200
	Double carriages	-	50	100	150	200	300	400	500	700	900	1100
Overall length	L4 (mm)	239	289	339	389	439	539	639	739	939	1139	1339
Weight without table plate and motor (kg)	Single carriage	5.3	5.8	6.2	6.8	7.3	8.5	9.5	10.6	12.7	14.9	17.0

Special- and intermediate strokes available on request!

A1	A2	A3	A4	A5	A6	A7	A8	B1	B2	B3	B4	B5	B6
65	56	31	7.5	8	*	5.5	56	140	116	144	147	*	50

B7	B11	L1	L2	L3	L5	L6	L7	L8	L11	ØM
120	131	100	200	15	23	*	*	*	84	*

* Dependent on the type of motor
All dimensions in mm. Subject to dimensional- and design modifications!

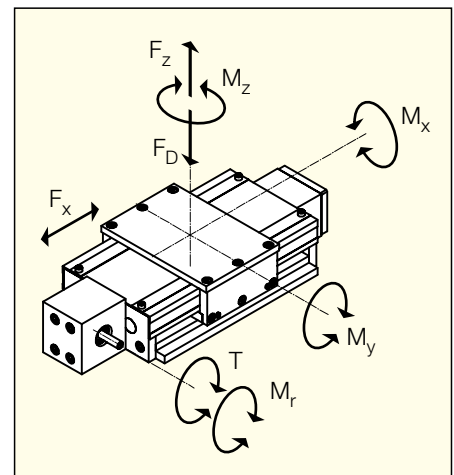
**5.1.3 Dimension Table
Type ALS 140-B
with Belt Drive**

Figure 4: Linear module
ALS 140-B-1-S-C-16T5-M-R



Technical Data

		ALS 140-B	ALS 140-B-H
Max. perm. central compressive force F_D per carr.	(N)	2000	4000
Max. perm. central tensile force F_z per carr.	(N)	1300	2800
Dynamic load bearing value C of the linear guideway* per carriage	(N)	4200	8800
Permissible bending moment with full support		Single carr.**	Single carr.**
M_x	(Nm)	47	94
M_y	(Nm)	40	80
M_z	(Nm)	40	80
Static friction moment M_f (with 1 carriage)	(Ncm)	15	15
Profile support recommended as from	(mm)	500	500
Maximum stroke**	(mm)	2500	2500
Installation position		any	any

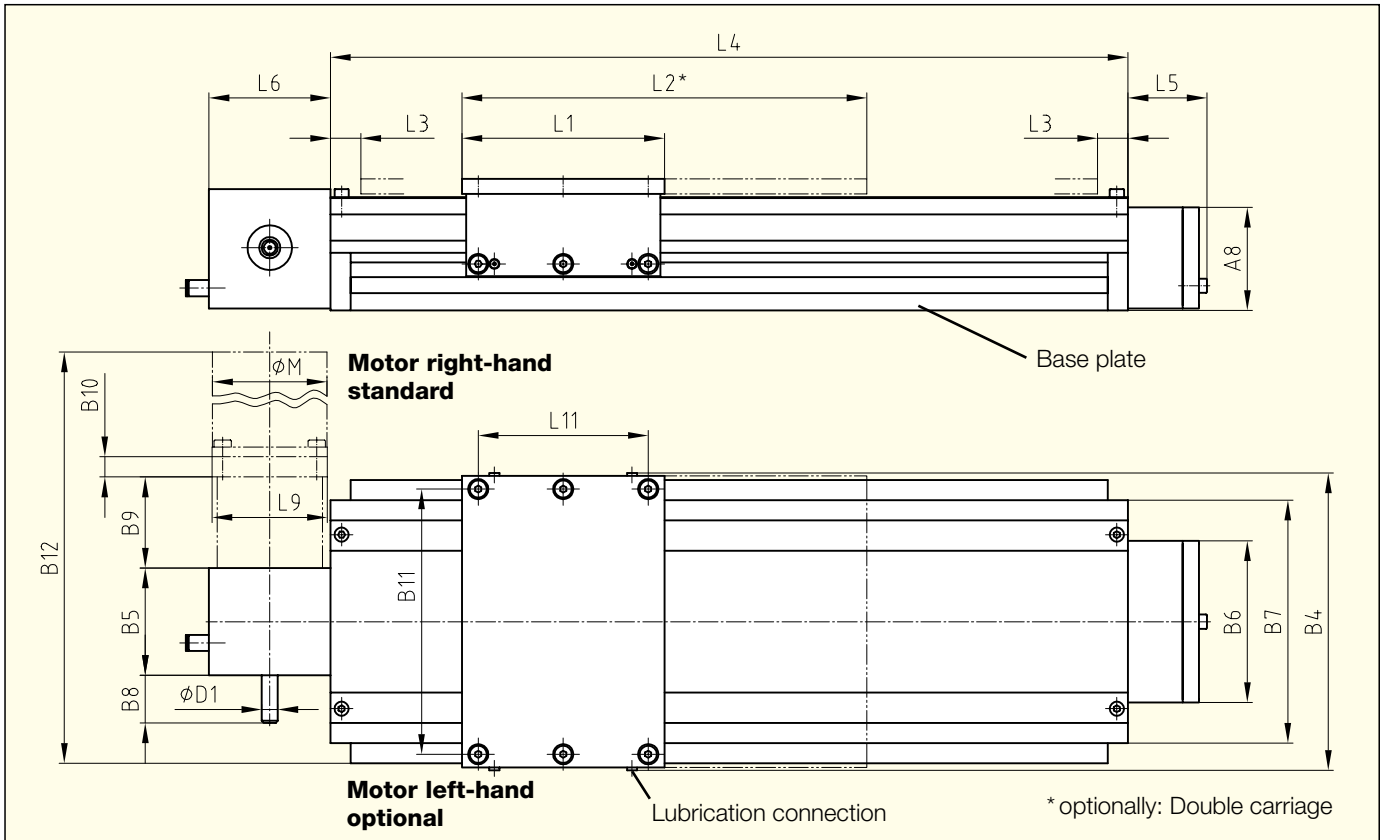


Type of Belt		16T5	25T5	25AT5
Max. perm. tensile force F_x of the belt	(N)	400	600	1200
Max. recommended load to be moved in case of great dynamism	(N)	100	200	300
Positioning accuracy***	(mm/m)	$\pm 0.15/0.3$	$\pm 0.15/0.3$	$\pm 0.15/0.3$
Repeatability***	(mm)	ca. ± 0.03	ca. ± 0.03	ca. ± 0.03
Feed per motor revolution without gearing	(mm)	50	60	105
Max. travelling speed v_{max}	(m/s)	1.0	1.5	2.0
Max. motor shaft diameter	(mm)	14	14	14
Max. drive torque T	(Nm)	2.5	4	8

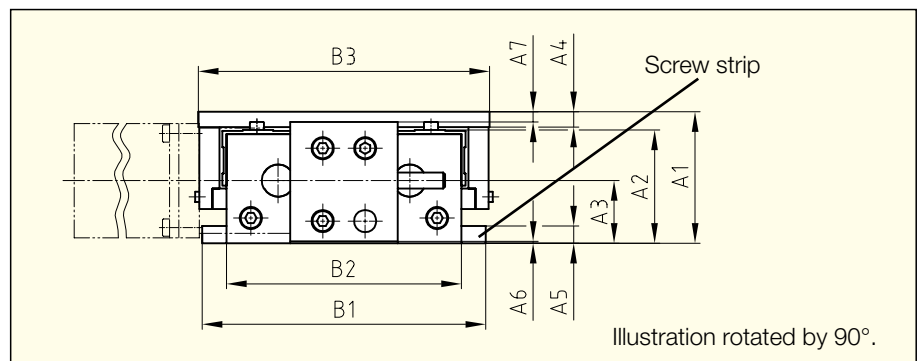
* In the direction of the principal load

** Values for double carriage are dependent on the carriage spacing

*** Dependent on the type of motor and belt



Type of belt	A6	A7	D1	B5	B8	L6
16T5	1	6	8	53	24	60
25T5	1	4	8	66	23	60
25AT5	0	7	10	68	28	74



Standard stroke (mm)	Single carriage	300	400	500	600	800	1000	1200	1500
	Double carriages	200	300	400	500	700	900	1100	1400
Overall length	L4 (mm)	439	539	639	739	939	1139	1339	1639
Weight without table plate and motor (kg)	Single carriage	6.7	7.5	8.3	9.1	10.8	12.5	14.2	16.8

Special - and intermediate strokes available on request!

A1	A2	A3	A4	A5	A8	B1	B2	B3	B4	B6	B7	B9	B10
65	56	31	7.5	8	51	140	116	144	147	80	120	*	*

B11	B12	L1	L2	L3	L5	L9	L11	ØM
131	*	100	200	15	39	*	84	*

* Dependent on the type of motor
All dimensions in mm. Subject to dimensional- and design modifications!

**5.1.4 Dimension Table
Type ALS 140-P with
Pneumatic Drive**

Figure 5: Linear module ALS 140-P-1-S-C

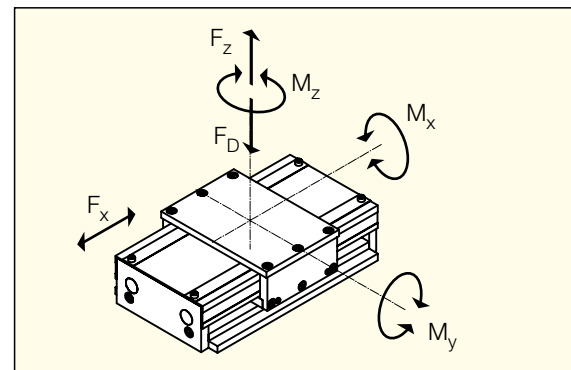
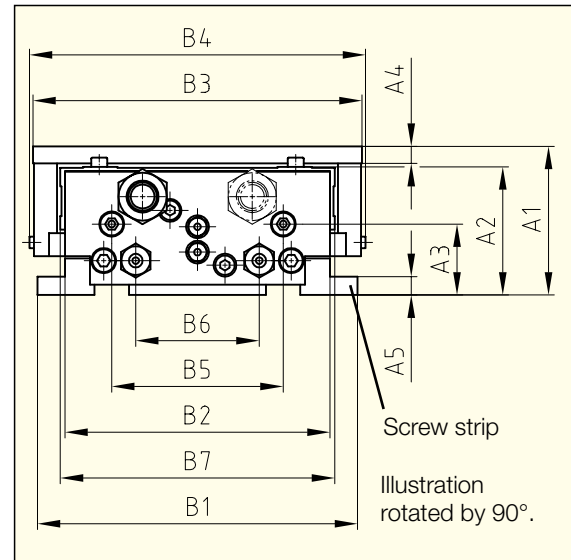


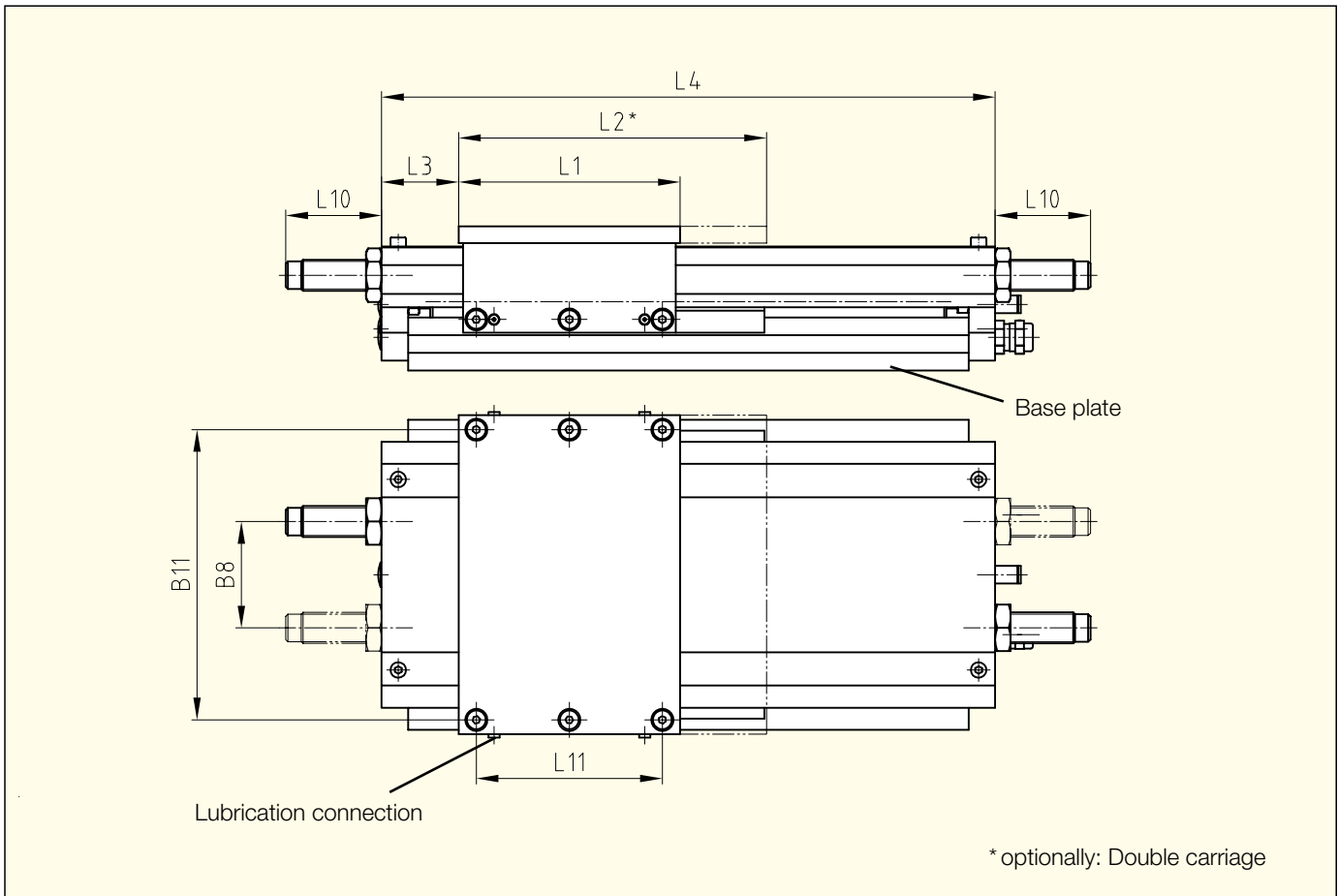
Technical Data

		ALS 140-P	ALS 140-P-H
Max. perm. central compressive force F_D per carr.		(N) 2000	4000
Max. perm. central tensile force F_z per carr.		(N) 1300	2800
Dynamic load bearing value C of the linear guideway* per carriage		(N) 4200	8800
Permissible bending moment with full support		Single carr.**	Single carr.**
M_x	(Nm)	47	94
M_y	(Nm)	40	80
M_z	(Nm)	40	80
Useful force F_x of the cylinder 6bar		(N) 150	150
Break-away force	Single carriage	(hPa (bar)) 1300 (1.3)	1300 (1.3)
	Double carriage	(hPa (bar)) 1500 (1.5)	1500 (1.5)
Maximum recommended load to be moved in case of great dynamism		(N) 50	50
Profile support recommended as from		(mm) 500	500
Maximum stroke**	Single Carriage	(mm) 1000	1000
	Double Carriage	(mm) 900	900
Installation position		any	any
Positioning accuracy		To stop	To stop
Adjustment of the limit position		up to 50 mm	up to 50 mm

* In direction of the principal load

** Values for double carriages are dependent on the carriage spacing





Standard stroke (mm)	Single carriage	100	150	200	250	300	400	500	600	800	1000
	Double carriage	-	50	100	150	200	300	400	500	700	900
Overall length	L4 (mm)	230	280	330	380	430	530	630	730	930	1130
Weight without table plate and motor (kg)	Single carriage	5.4	5.9	6.4	6.9	7.4	8.4	9.4	10.4	12.4	14.4
	Double carriage	-	6.8	7.3	7.8	8.3	9.3	10.3	11.3	13.3	15.3

Special - and intermediate strokes available on request!

A1	A2	A3	A4	A5	B1	B2	B3	B4	B5	B6	B7	B8	B11
65	56	31	7.5	8	140	116	144	147	75	80	120	48	131

L1	L2	L3	L10	L11
100	200	15	43	84

All dimensions in mm. Subject to dimensional- and design modifications!

5.2 Accessories – to be ordered separately

2nd carriage (double carriage) DW

To achieve significantly higher torque load-bearing capacity and the doubling of the load bearing capacity, a second carriage can be utilized. A correspondingly lengthened table plate is part of the scope of supply.
The available stroke is reduced by 100mm.

Reference-/limit switch PNP

The inductive switches are available both as normally closed PNP and normally open PNP (10 ... 30V). The free cable length is approx. 2m.

Side covering SC

In case of rotated by 90° or 180° around the longitudinal axis installation (base plate on top), dirt may possibly penetrate inside through the gap. Depending on the amount of contamination, this side covering has to be foreseen.

Coupling CP

Corresponding to the selected motor, a suitable coupling has to be chosen.

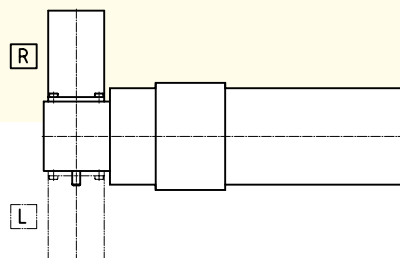
Motor flange MF

The motor flange serves to adapt the motor to the coupling housing.

5.3 Ordering Information

Linear module ALS

	—	ALS	140	-0500	-B	-1	-S	-C	-16T5	-O	-R
Quantity											
Type	ALS										
Size	140										
Stroke in mm											
Type of drive	O	Without drive									
	S	Ball screw drive									
	B	Belt drive									
	P	Pneumatic cylinder									
Number of carriages	1	Single carriage									
	2	Double carriages									
Bushing version	S	Standard									
	H	Increased load-bearing capacity									
Covering	C	Cover plate (standard)									
Type of drive (only in case of ball screw- or belt drive)	K12×5, K16×10, K16×16*, K16×50* in case of drive type S 16T5, 25T5, 25AT5 in case of drive type B										
Motor (only in case of ball screw- or belt drive)	O	Without motor or -adapter									
	M	With motor adapter or motor mounting (to be specified separately)									
Motor position (only in case of belt drive)	R	Motor/drive right-hand (standard)									
	L	Motor/drive left-hand									



* Only available on request

Accessories linear module 140 – to be ordered separately

Reference-/limit switch

		—	PNP	-O	-140
Quantity					
Designation	PNP				
Type	O Normally closed S Normally open				
Size	140				

2nd (double carriage)

		—	DW	-140
Quantity				
Designation	DW			
Size	140			

Side covering

		—	SC	-140	-639
Quantity					
Designation	SC				
Size	140				
Length L4 in mm					

Coupling

		—	CP	-140	-S
Quantity					
Designation	CP				
Size	140				
Type	S Special version (the motor has to be specified)				

Motor flange

		—	MF	-140	-S
Quantity					
Designation	MF				
Size	140				
Version	S Special version (the motor has to be specified)				

Damper-kit (additional)

		—	DP	-140	-P
Quantity					
Designation	DP				
Size	140				
Type	P				

6.1 Product Characteristics ARS

As a complement to the linear modules, the rotary module ARS was developed.

All rotating elements move within an oil bath. The sealed housing allows any required vertical and horizontal installation positions.

By using optimally dimensioned cross-roller bearings for the rotating table, these modules can accept very high axial and radial forces.

With single or double bearing supports for the worm gear shafts, rapid positioning as well as precise reversing operation is possible.

The worm drive, through an eccentric cam, can be adjusted to have practically no play (backlash). The drive consists of a carefully selected combination of materials with low wear.

The large dimensioned through bore is particularly suitable for pass-through applications and for the passing through of lines or cables.

The numerous accessories, such as base plates and table plates, reference switches, motors and control systems have to be ordered separately.

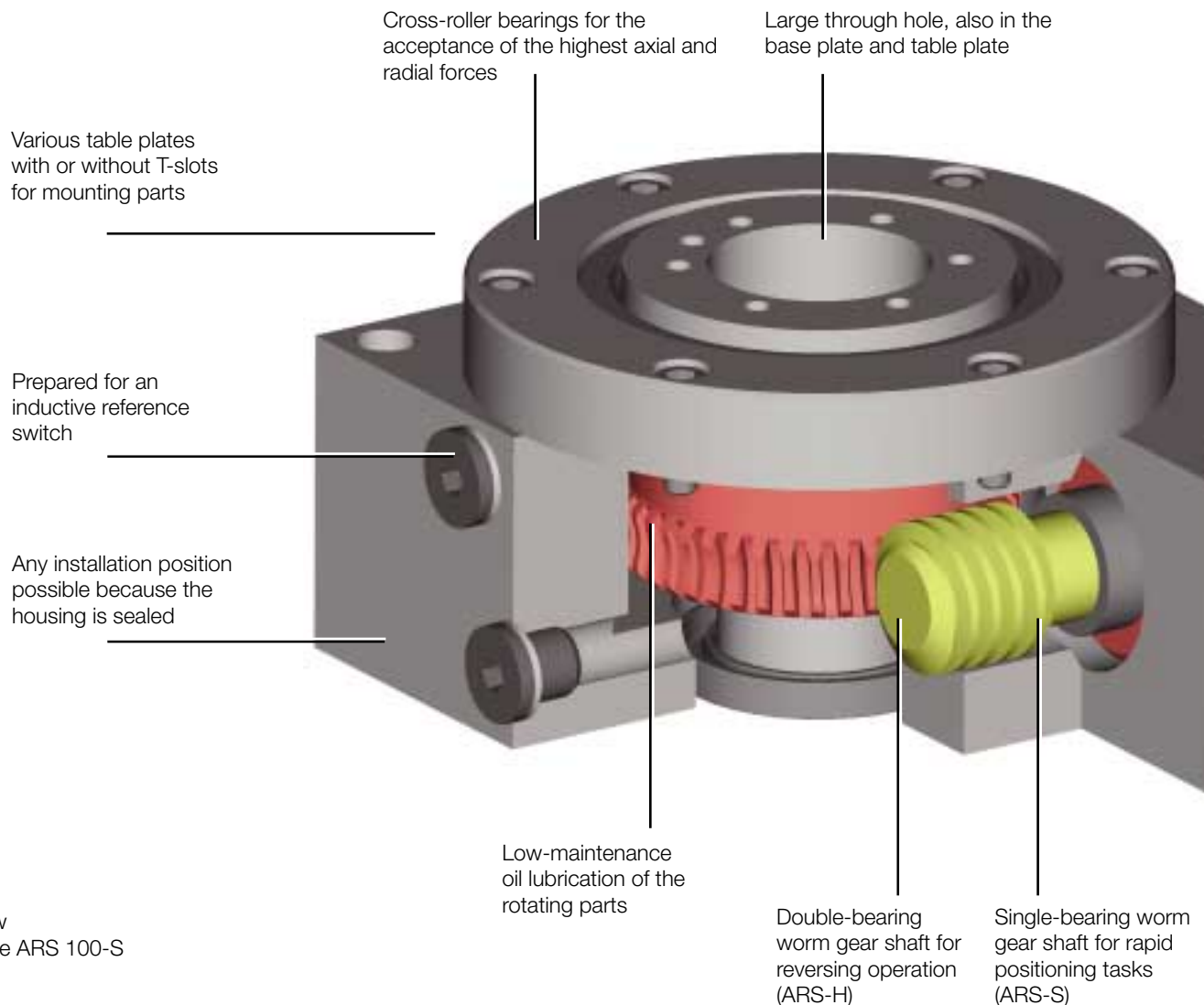
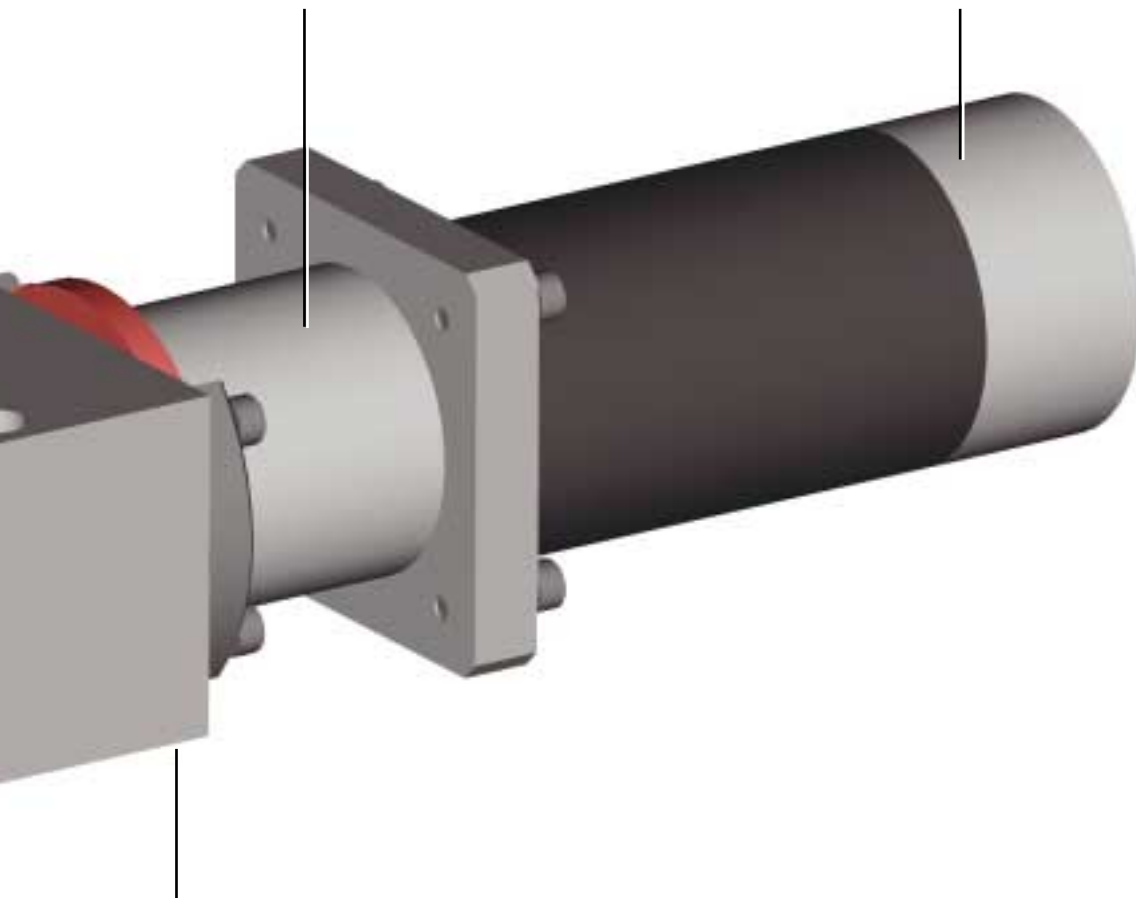


Figure 1:
Selection view
Rotary module ARS 100-S

Coupling housing with motor
flange and coupling

Possible attachment of commercially available motors
(2-, 3- or 5-phase stepping motors or DC/AC-servomotors)



Adaptation of the base plate is possible

6.2 Technical Data Type ARS-S

Figure 2: Rotary module ARS 100-S-O-O-M-R



		ARS 100-S	ARS 200-S	ARS 300-S
Transmission ratio worm gear i		45:1	72:1	90:1
Perm. static central load bearing cap. (N)		8500	13500	45000
Perm. static tilting (tipping) moment (Nm)		200	400	1500
Permissible static torque (Nm)		150	500	800
Positioning accuracy* (°)		±0.05	±0.020	±0.015
Repeatability* (°)		±0.010	±0.010	±0.010
Concentricity-axial run-out (wobble) (mm)		<0.01	<0.01	<0.01
Maximum positioning speed* (°/s)		180	180	150
Maximum drive torque** (Nm)		2	3.5	5
Weight*** (kg)		5.8	11	31.8
Weight of base plate BV (kg)		1.4	3.8	9.5
Weight of base plate BH (kg)		1	2	5.2

* Dependent on the selected motor (without load)

** Counter-clockwise; in clockwise direction, the values have to be reduced by 50%

*** Without motor and base plate

6.3 Technical Data Type ARS-H

Figure 3: Rotary module ARS 100-H-O-O-M-R

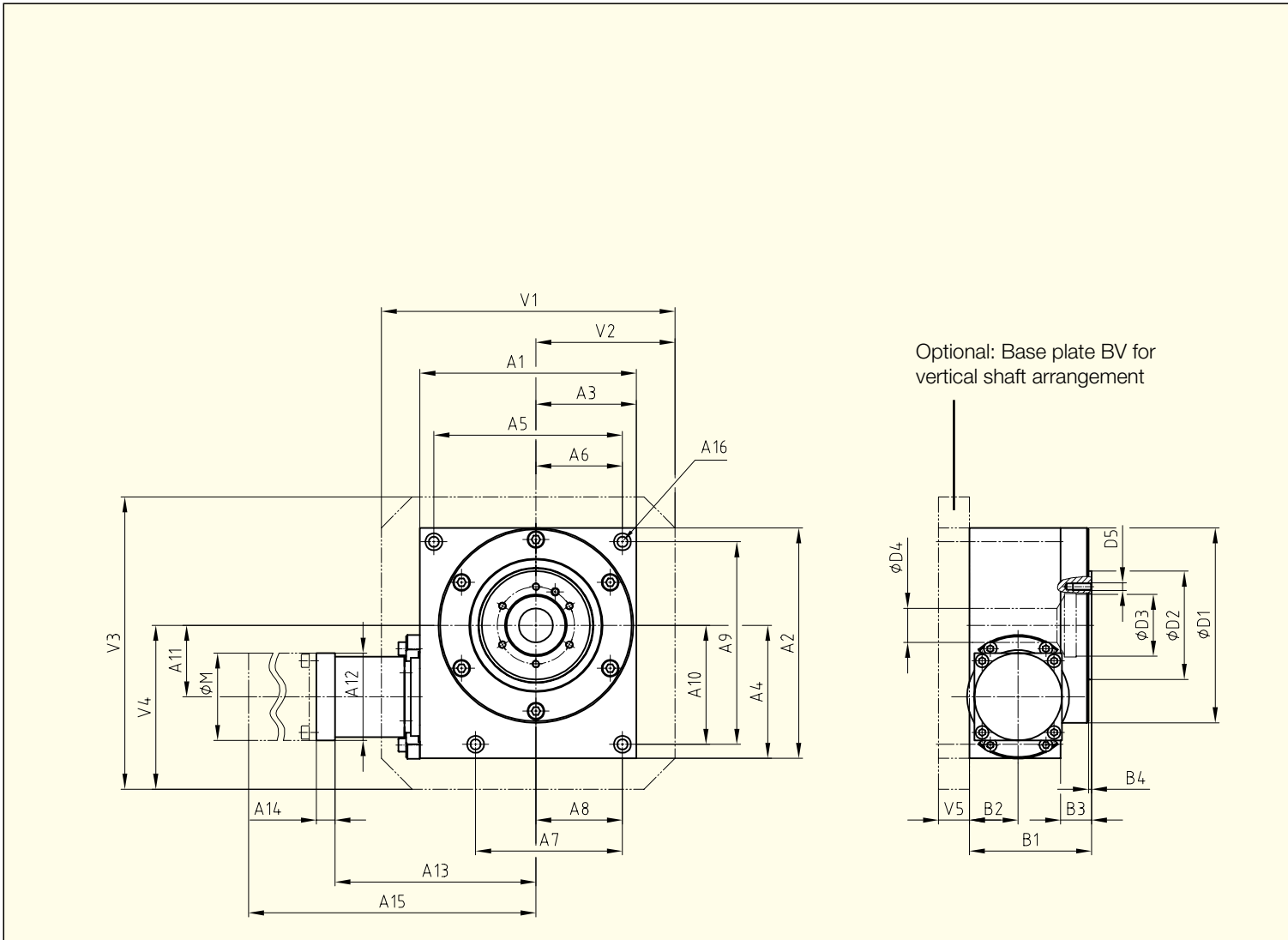


		ARS 100-H	ARS 200-H	ARS 300-H
Transmission ratio worm gear i		45:1	72:1	90:1
Perm. static centr. load bearing cap.	(N)	8500	14000	35000
Perm. static tilting (tipping) moment	(Nm)	200	450	1500
Permissible static torque	(Nm)	250	600	1000
Positioning accuracy*	(°)	±0.05	±0.020	±0.015
Repeatability*	(°)	±0.010	±0.010	±0.010
Concentricity-axial run-out (wobble)	(mm)	<0.01	<0.01	<0.01
Maximum positioning speed*	(°/s)	180	180	150
Maximum drive torque	(Nm)	2	3.5	5
Weight**	(kg)	8	14.3	38.4
Weight of base plate BV	(kg)	1.9	3.9	9.7
Weight of base plate BH	(kg)	1.1	2.4	5.7

* Dependent on the selected motor (without load)

** Without motor and base plate

6.4 Dimension Table Type ARS-S

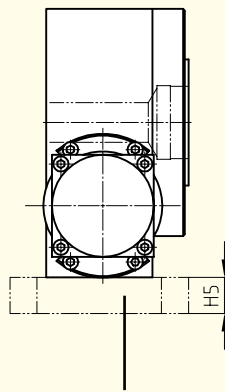
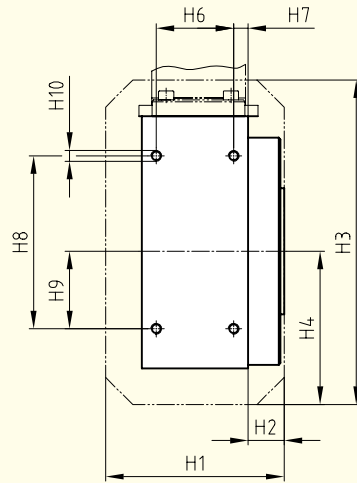


Details of reference switching point and motor connection dimensions on request!

	A1	A2	A3	A4	A5	A6	A7	A8	A9	A 10
ARS 100-S	140	149	65	86	122	56	95	56	131	77
ARS 200-S	200	200	100	112	120	60	120	60	180	102
ARS 300-S	260	299	130	169	220	110	160	80	259	149

	D1	D2	D3	D4	D5	H1	H2	H3	H4	H5
ARS 100-S	125	70	40H7	22	TK= 50, 6×M5-12 deep	99	20	180	85	20
ARS 200-S	170	100	60H7	50	TK= 78, 4×M8-10 deep	114	27.5	255	127.5	25
ARS 300-S	255	165	120H7	95	TK= 145, 6×M6-12 deep	176	35	330	165	30

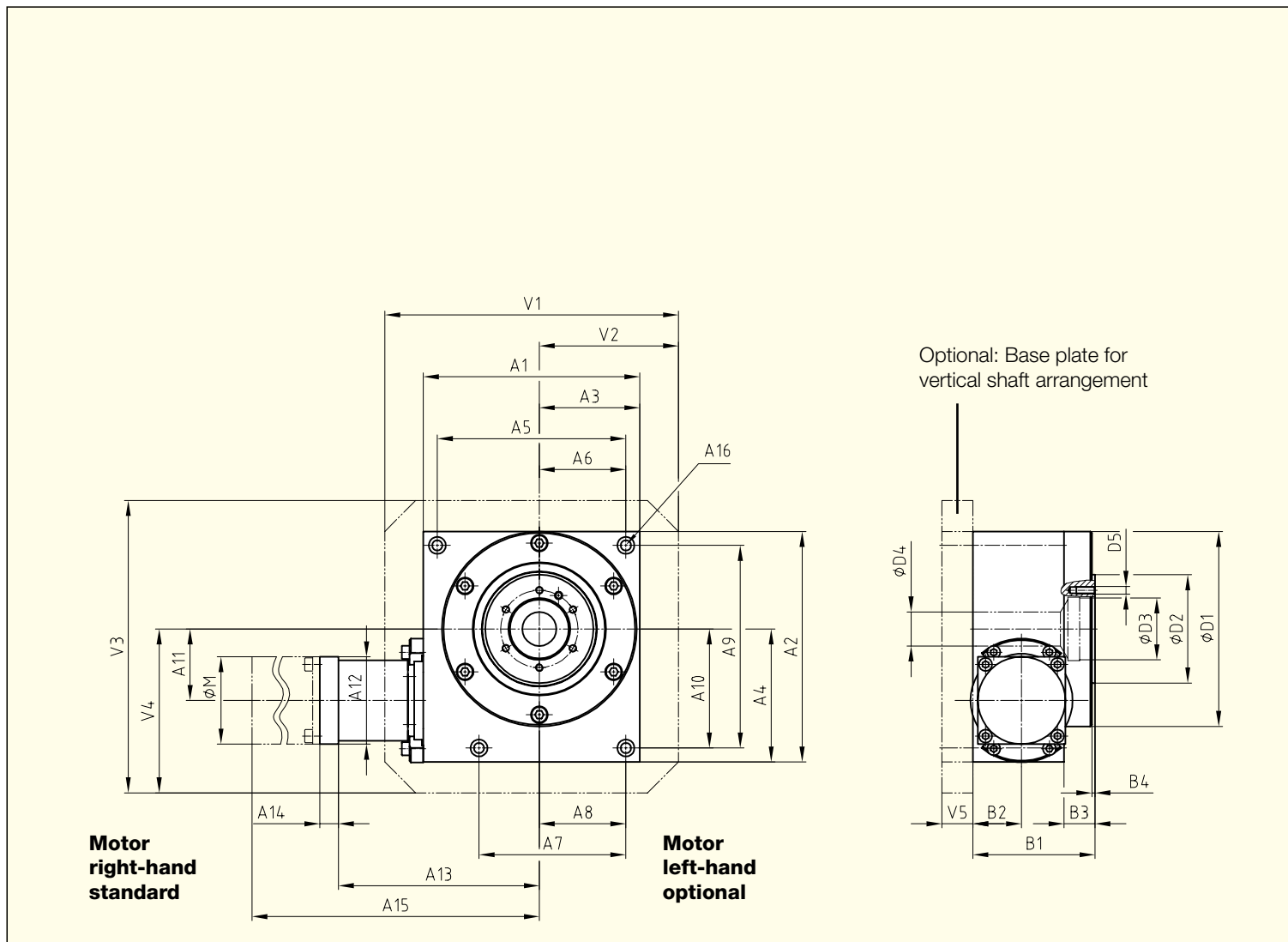
* Dependent on the type of motor
All dimensions in mm. Subject to dimensional and design modifications!



Optional: Base plate BH
for horizontal shaft arrangement

A11	A12	A13	A14	A15	A16	ØM	B1	B2	B3	B4
46.3	*	*	*	*	Km6 DIN 74, M8-16 deep	*	79	33	20	2
66.5	*	*	*	*	Km8 DIN 74, M10-20 deep	*	84	31.5	25	2
104	*	*	*	*	Km12 DIN 74, M16-32 deep	*	125	56.4	19.4	5.4
H6	H7	H8	H9	H10	V1	V2	V3	V4	V5	
43	8	96	43	M6-10 deep	180	85	189	106	20	
44	7.5	150	75	M8-16 deep	255	127.5	255	139.5	25	
66	19.6	210	105	M8-18 deep	330	165	369	204	30	

6.5 Dimension Table Type ARS-H



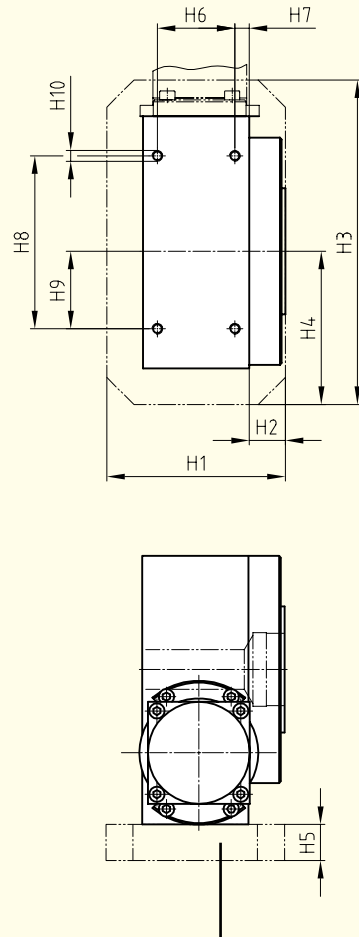
Details of reference switching point and motor connection dimensions available on request!

	A1	A2	A3	A4	A5	A6	A7	A8	A9	A 10
ARS 100-H	150	160	75	90	80	40	80	40	140	80
ARS 200-H	186	225	93	132	120	60	120	60	205	122
ARS 300-H	290	331	145	186	240	120	110	55	270	170

	D1	D2	D3	D4	D5	H1	H2	H3	H4	H5
ARS 100-H	120	70f7	50H7	25.3+0.2	TK= 60, 6×M6-10 deep	100	13	200	75	19
ARS 200-H	160	100f7	60H7	50.4+0.2	TK= 78, 4×M8-12 deep	150	36	250	125	25
ARS 300-H	236	130g6	85H7	85H7	TK= 110, 6×M6-12 deep 6×M8-12 deep	220	52	350	145	30

* Dependent on the type of motor

All dimensions in mm. Subject to dimensional and design modifications!



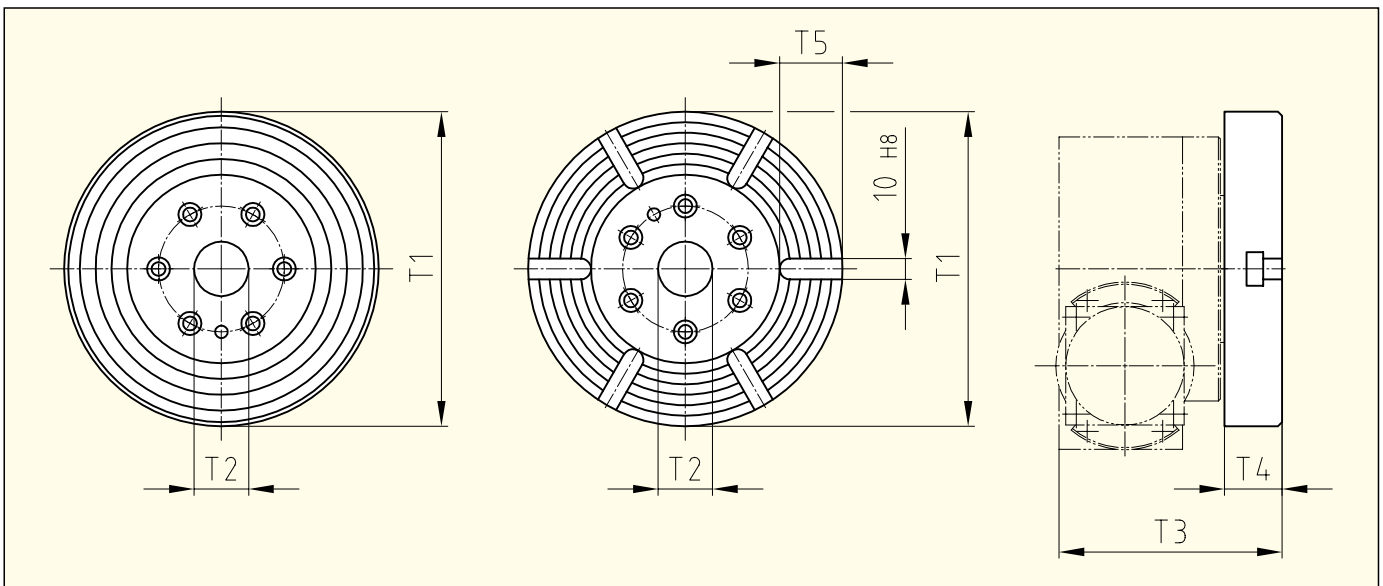
Optional: Base plate BH
for horizontal shaft arrangement

A11	A12	A13	A14	A15	A16	ØM	B1	B2	B3	B4
51.5	*	*	*	*	Km8 DIN 74, M10-20 deep	*	93	36	18	3
86	*	*	*	*	Km8 DIN 74, M10-20 deep	*	92	37.5	15	5
128	*	*	*	*	Km12 DIN 74, M16-32 deep	*	126	54	10	5

H6	H7	H8	H9	H10	V1	V2	V3	V4	V5
59	8	50	25	M8-16 deep	200	100	200	110	19
44	17	150	75	M8-15 deep	240	120	280	160	25
52	31	190	95	M14-32 deep	350	175	390	215	30

6.6 Accessories – to be ordered separately

- Reference switch PNP
The inductive switches are available both as PNP normally closed as well as PNP normally open (10...30V). The free cable length is approx. 2m.
- Base plate BV/BH
For the adaptation on the surroundings, base plate type BV (vertical shaft arrangement), or type BH (horizontal module axis) is available.
- Table plate T
For receiving, e. g. work-pieces, instruments and other parts, table plates in various sizes and with or without T-slots are available.



Size	Type	T1	T2	T3	T4	T-slot DIN 650 number	T5	T6	Utilization with horizontal module axis	Weight (kg)	
										without slot	with slot
100	TK	150	26	115.5	27.5	4	30	8H7	x	3.2	3.0
	TG	200	26	115.5	27.5	4	55	8H7	-*	5.9	5.5
200	TK	200	26	113	27.5	4	40	8H7	x	5.9	5.5
	TG	300	26	123	37.5	6	90	8H7	-*	17.1	16.5
300	TK	300	26	155	37.5	6	80	12H7	x	17.1	16.5
	TG	400	26	155	37.5	6	130	12H7	-*	24.3	23.5

* The table plate protrudes over the external contour of the rotary module! On request, a special base plate is available.
All dimensions in mm. Subject to dimensional and design modifications!

- Coupling CP
Corresponding to the selected motor, a coupling suitable for it has to be selected.
- Motor flange MF
The motor flange serves to adapt the motor to the coupling housing.

6.7 Ordering Information

Rotary module ARS

		—	ARS	100	-H	-TKO	-BV	-M	-R
Quantity									
Type	ARS								
Size	100, 200, 300								
Worm gear shaft bearing	S Single H Double								
Table plate	O Without table plate TKO Table plate small without slots TKM Table plate small with slots TGO Table plate large without slots TGM Table plate large with slots								
Base plate	O Without base plate BH Base plate for horizontal application BV Base plate for vertical application								
Motor	O Without motor or -adapter M With motor adapter or motor mounting (to be specified separately)								
Motor position*	R Motor/drive right-hand (standard) L Motor/drive left-hand (only in case of version -H)								

* In case of the orientation of the motor vertically upwards, this indispensable has to be indicated in the order!

Accessories rotary module ARS – to be ordered separately

Reference switch

		—	PNP	-O	-ARS
Quantity					
Designation	PNP				
Type	O Normally closed S Normally open				
Version	ARS Applicable for all types of module				

Coupling

		—	CP	-100	-S
Quantity					
Designation	CP				
Size	100, 200, 300				
Type	S Special version (the motor has to be specified)				

Motor flange

		—	MF	-100	-S
Quantity					
Designation	MF				
Size	100, 200, 300				
Version	S Special version (the motor has to be specified)				

7.1 Motors

All SCHNEEBERGER linear modules are designed and built to be driven by a great variety of 2-, 3-, or 5-phase stepping motors or DC/AC-servomotors. The motors can be adapted to the motor flanges foreseen for this purpose without any problems. All motors are of course compatible with the control and amplification units supplied by SCHNEEBERGER on request.

For simple positioning tasks without any path monitoring, the cost-effective stepping motors are best utilized. In applications that require high accuracy, speed of revolution, or dynamism, AC-servomotors are preferred.

7.2 Control Systems

For all types of motors, we are in a position to offer our customers single and multi-axis control systems. The control systems are also available in compact units with integrated amplifiers, ready to be plugged in for 230 Volt operation. (110V power supply deliverable on request.)

All control systems have an easy to operate menu system (on the integrated display or by means of a PC tie-in). In this case, the CNC-operation can be parameterized as required for stepping- or for servomotors.

Through the integrated SPS-control system, the user is in a position to not only implement multi-axis positioning processes, but also monitor cyclical periphery operations and logical connections. This provides the ideal prerequisite for the automation of a complete installation, in combination with the correct linear module configuration.

The following functions can be implemented with a single unit:

- Multi-axis positioning processes (linear-, circular-, helix interpolation)
- Cyclical peripherals driving/ -monitoring
- Operator guidance on the LCD display or directly through the PC
- Operator input on the LCD display/PC (such as, e.g., work-piece numbers, number of pieces, etc.)
- Language change of the menu user guidance (German, English, French, Dutch)

8.1 General

The linear modules can be combined into the most diverse handling systems. For more details please refer to chapter 8.2.

The installation of the respective axes in the case of many combinations is effected by the direct screw-connection of the individual axes. In these cases, the overall height corresponds to the sum of the height of the individual axes. For certain axis arrangements, intermediate adapter plates are necessary, which increases the overall height.

The **arrangement of the axes**, i.e. the position of the base plate (underneath or on top) is freely selectable.

In case of a utilization of the linear module ALS 140 in a position rotated by 90° or 180° around the longitudinal axis (base plate on top), it is possible that dirt can penetrate into the interior space through the lateral gap. Depending on the degree of contamination with dirt, a side covering of the type SC-140 has to be provided by the user. In preference, the linear module ALS 140 should be used in the normal axis arrangement (base plate underneath), because in this installation position an adequate protection against contamination with dirt is assured.

The **installation arrangement** is defined in such a manner, that the x-axis is always underneath and the y-axis correspondingly always on top.

The respective Installation- and axis arrangement has to be indicated in a drawing together with the order, refer to chapter 9. The position of the motors has to be indicated in accordance with the direction of rotation.

Handling systems are assembled and adjusted in the factory. Larger units are dismantled again for transportation.

8.2 Installation Arrangements

Figure 1: Combination

X-axis: ALM 70-B-2-M-R, supporting axis ALM 70-O-1-O

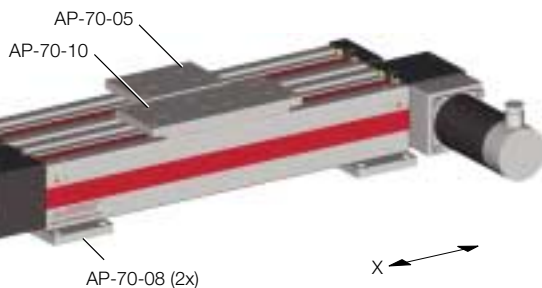


Figure 2: Cross arrangement

X-axis: ALS 140-S-1-S-C-K12×5-M

Y-axis: ALM 70-S-2-M

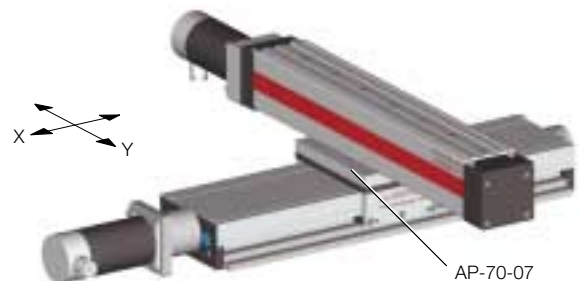


Figure 3: Cross arrangement

X-axis: ALM 70-B-1-M-R
Y-axis: ALM 70-B-1-M-R

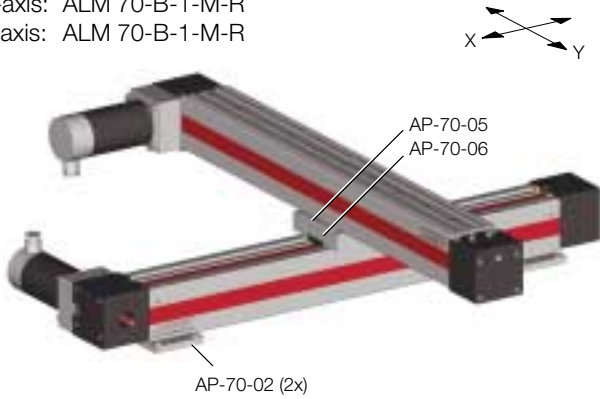


Figure 4: Cross arrangement

X-axis: ALM 70-B-1-M-R, supporting axis ALM 70-O-1-O
Y-axis: ALM 70-B-2-M-R

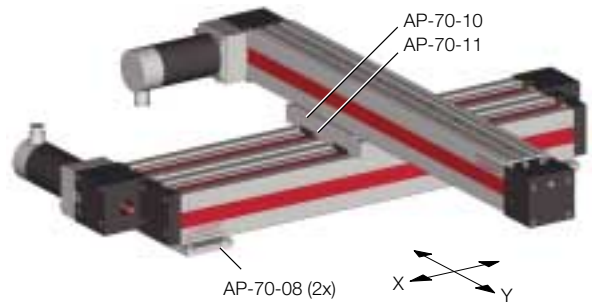


Figure 5: Boom system

X-axis: ALM 70-B-1-M-R
Y-axis: ALM 70-B-1-M-R

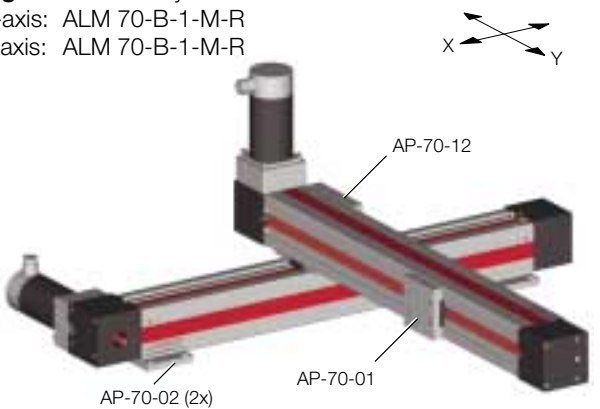


Figure 6: Boom system

X-axis: ALM 70-B-1-M-R
Y-axis: ALM 70-B-1-M-R
Z-axis: ALM 70-S-1-M

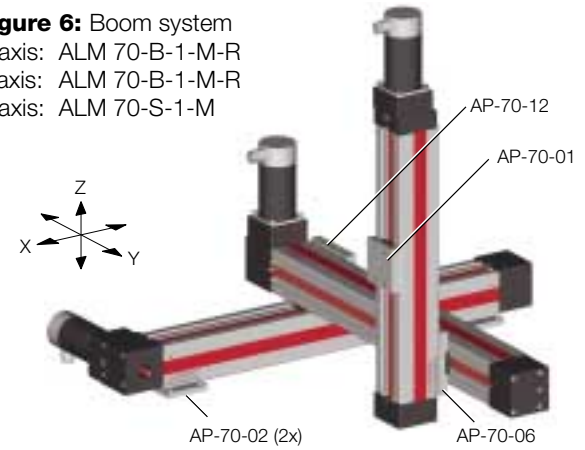


Figure 7: Boom system

X-axis: ALM 70-B-1-M-R,
supporting axis ALM 70-O-1-O
Y-axis: ALM 70-B-2-M-R
Z-axis: ALM 70-S-1-M

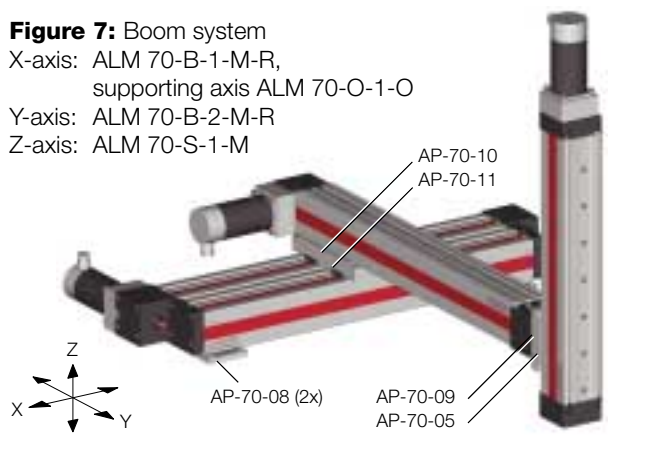


Figure 8: Boom system

X-axis: ALM 70-B-1-M-R
Y-axis: ALM 70-B-1-M-R
Z-axis: ALM 70-S-1-M

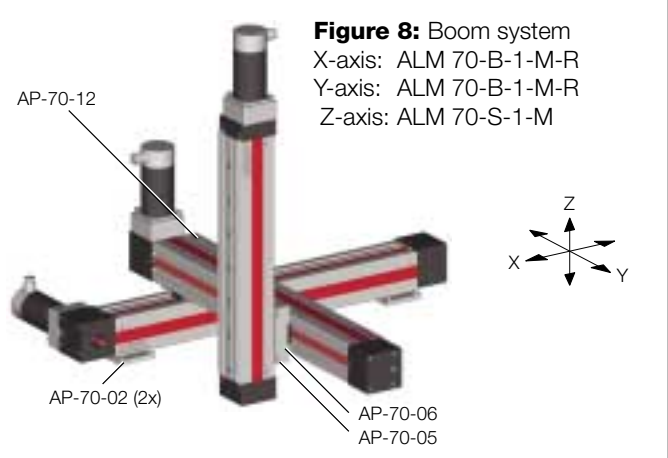


Figure 9: Frame coordinate table

X-axis: ALM 70-B-2-M-R, supporting axis ALM 70-O-2-O
Y-axis: ALM 70-B-2-M-R, supporting axis ALM 70-O-2-O

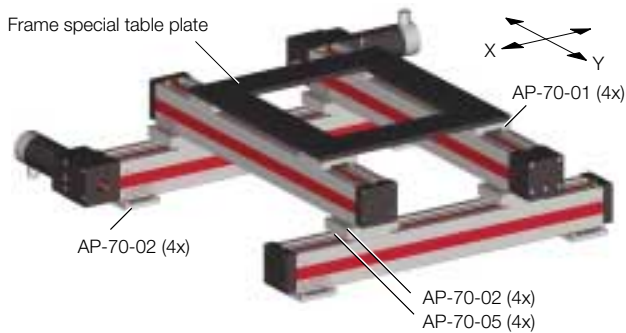


Figure 10: Portal

X-axis: ALM 70-B-2-M-R, supporting axis ALM 70-O-2-O
Y-axis: ALS 140-S-1-S-C-K12x5-M

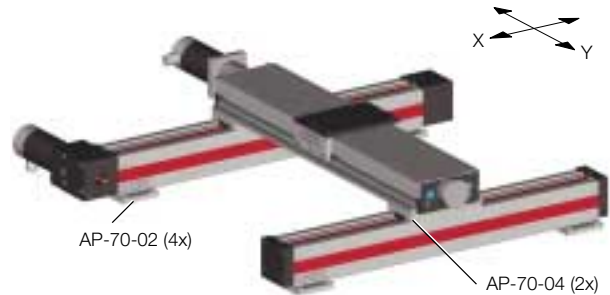


Figure 11: Portal

X-axis: ALM 70-B-1-M-R, supporting axis ALM 70-O-1-O
Y-axis: ALM 70-B-1-M-R

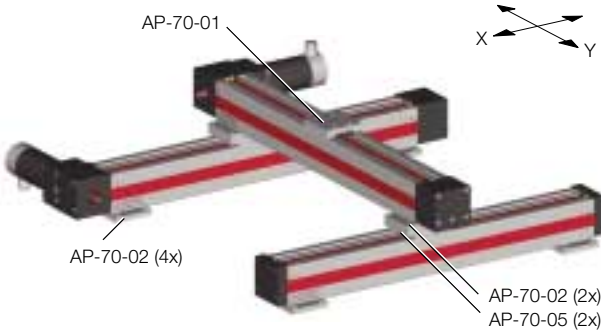


Figure 12: Portal

X-axis: ALM 70-B-2-M-R, supporting axis ALM 70-O-2-O
Y-axis: ALM 70-B-1-M-R, supporting axis ALM 70-O-1-O

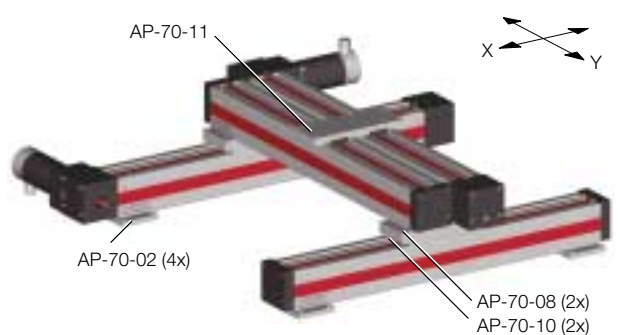


Figure 13: Center drive MD for portal

X-axis: ALM 70-S-1-O (2x)

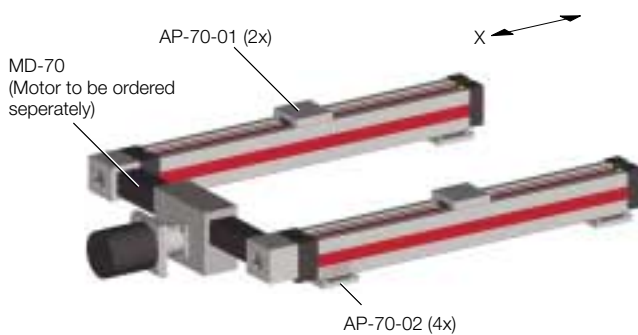


Figure 14: Universally jointed shaft CW for portal

X-axis: ALM 70-B-1-M-R, ALM 70-B-1-O-R
Y-axis: ALM 70-B-1-M-R

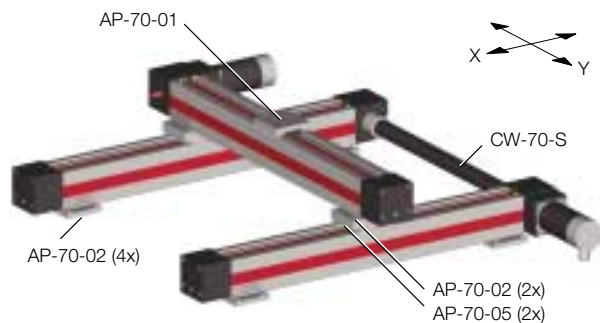


Figure 15: Universally jointed shaft CW for portal
 X-axis: ALM 70-B-2-M-R, ALM 70-B-2-O-R
 Y-axis: ALM 70-B-1-M-R, supporting axis ALM 70-O-1-O

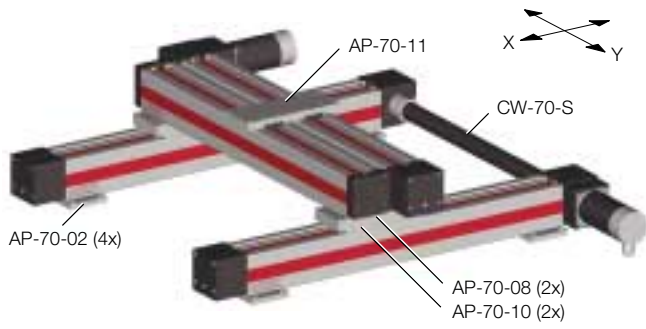
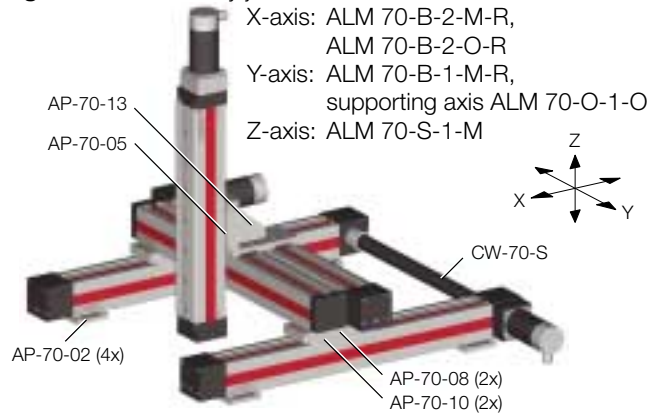


Figure 16: Universally jointed shaft CW for coordinate
 X-axis: ALM 70-B-2-M-R,
 ALM 70-B-2-O-R
 Y-axis: ALM 70-B-1-M-R,
 supporting axis ALM 70-O-1-O
 Z-axis: ALM 70-S-1-M



Date:	⇒ Fax
	⇒ E-mail

Customer

Company		Department	
Contact person		Telephone	
Street		Fax	
Zip code / City		E-mail	
Country		Homepage	

Description of the Application

Type of machine / application		Name of the machine	
-------------------------------	--	---------------------	--

Axis	Position	X		Y		Z	
		horizontal	vertical	horizontal	vertical	horizontal	vertical
Stroke	(mm)						
Load	(kg)						
Speed	(m / s)						
Acceleration	(m / s ²)						
Duration of cycle	(s)						
Stroke per cycle	(mm)						
Positioning accuracy	(mm)						
Reverse play (backlash)	(mm)						
Repeatability	(mm)						
Max. installed dimensions	(mm)						

 Remarks (or sketch):

Sales Information

Alternative for		Prototype in calendar week	
Annual sales potential (pieces)		Trial sample in calendar week	
Target price (Euro)		Start of the series deliveries in calendar week	
Remarks			

Drive

- Without drive
- With motor flange
- With coupling
- With servomotor (AC/DC)
- With stepping motor (2-, 3-, 5-phases)
- With shaft encoder
- With gearing $i = _ : _$

Control System

- SPS for _____ axes
- CNC for _____ axes
- Inductive switches
 - PNP-Normally closed
 - PNP-Normally open
- Mechanical limit switches
- Electric cubicle/terminal box
- 230V-power supply 110V-power supply

Sketch (particularly important: Indicate the position of the motors in the sense of rotation)

Lowest axis: X
Top axis: Y

10.1 General Safety Information

- Operating instructions are provided with every product. These operating instructions must be readily available to the operating and maintenance personnel.
- They contain safety regulations, installation and maintenance instructions and an assembly.
- The information in these operating instructions is only applicable for the product, the equipment number of which is listed on the title page of the operating instructions.
- After the operating instructions have been carefully studied by the operating and maintenance personnel, the product can be put into operation.

In case of improper use and unauthorized modification to functional components of the product, SCHNEEBERGER will not assume any liability!

- If malfunctions should occur, which cannot be remedied, SCHNEEBERGER will be happy to be of assistance. In doing so the **indication of the equipment number** is important!

10.2 Remarks concerning Dangers/Hazards



The products have been developed in accordance with the current state of the technology and they are operationally safe. Before they are put into operation, however, we would like to point out the following risks of personal injury:

- Depending on the installation position and the transporting weight (specific to the customer) of the linear modules, it is possible that, because the runner carriage is not self-locking, during its movement as a result of its own and transport weight a crushing of hands as a result of the impact of the runner carriage at both limit stops cannot be excluded.

! Remedy by means of the affixing of a protective device, e.g., a protection screen

- Depending on the installation position of the rotary modules, oil can leak out of the filling stoppers. For this reason attention must be taken, that the position of the filling stopper has been selected in such a manner, that any leaking of the oil is prevented. If this is technically not feasible, then special venting stoppers have to be used.
- The freely rotating shaft pin (foreseen for the attachment of brakes, universal joint shafts, etc.) on the drive side (bearing housing of the crown gear) of the driving crown gear can grab, wind-up or catch objects in its vicinity.

! Remedy by removing the freely rotating shaft pin (if it is not required), or by covering it with a protective hood

- When driving the unit with motors (option), independent of the installation position and of the transport weight, it is possible that as a result of the energy stored during the movement of the runner carriage a crushing of hands as a result of the impact of the runner carriage at both limit brackets cannot be excluded.

! Remedy by means of the affixing of a protective device, e.g., a protection screen

- When the unit is driven with motors (option), as a result of heat build-up of the motor, it is not possible to exclude that, when the motor is touched with bare hands, burns to the skin can occur.

! Remedy by affixing a protection device, e.g., a protection screen

- During all repair and maintenance work, the units have to be isolated from any electric voltages and have to be secured against being switched on again. If this is not carried out, unforeseeable damage to the equipment as well as physical injuries can result from electric shock and over-voltages.



SWITZERLAND

W. Schneeberger AG
CH-4914 Roggwil/BE
Phone 062 918 41 11
Fax 062 918 41 00

E-Mail:
info-ch@schneeberger.com
www.schneeberger.com

GERMANY

Schneeberger GmbH
75339 Höfen/Enz
Phone 07081 782-0
Fax 07081 782-124

E-Mail:
info-d@schneeberger.com

ITALY

Schneeberger S.p.A
21021 Angera VA
Phone 0331 93 20 10
Fax 0331 93 16 55

E-Mail:
info-i@schneeberger.com

FRANCE

Schneeberger
Technique Linéaire SARL
91222 Brétigny-sur-Orge
Phone 01 69 88 50 00
Fax 01 60 84 96 02

E-Mail:
info-f@schneeberger.com

USA

Schneeberger Inc.
Bedford, MA 01730
Phone +1 781-271-0140
+1 800-854-6333
Fax +1 781-275-4749

E-Mail:
info-usa@schneeberger.com

