

# Advantages of Caged Ball™ Technology

High speed performance  
Low noise design, Long service life,  
Long-term maintenance-free operation  
Reduction in rolling resistance variation

**SRS**



Revised basic dynamic load ratings

US, EPC,  
Patent Pending

**THK CO., LTD.**  
TOKYO, JAPAN

CATALOG No.249-5E

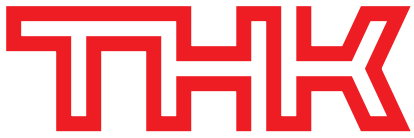

# LM Guide with Caged Ball™ Technology Compact series

# SRS

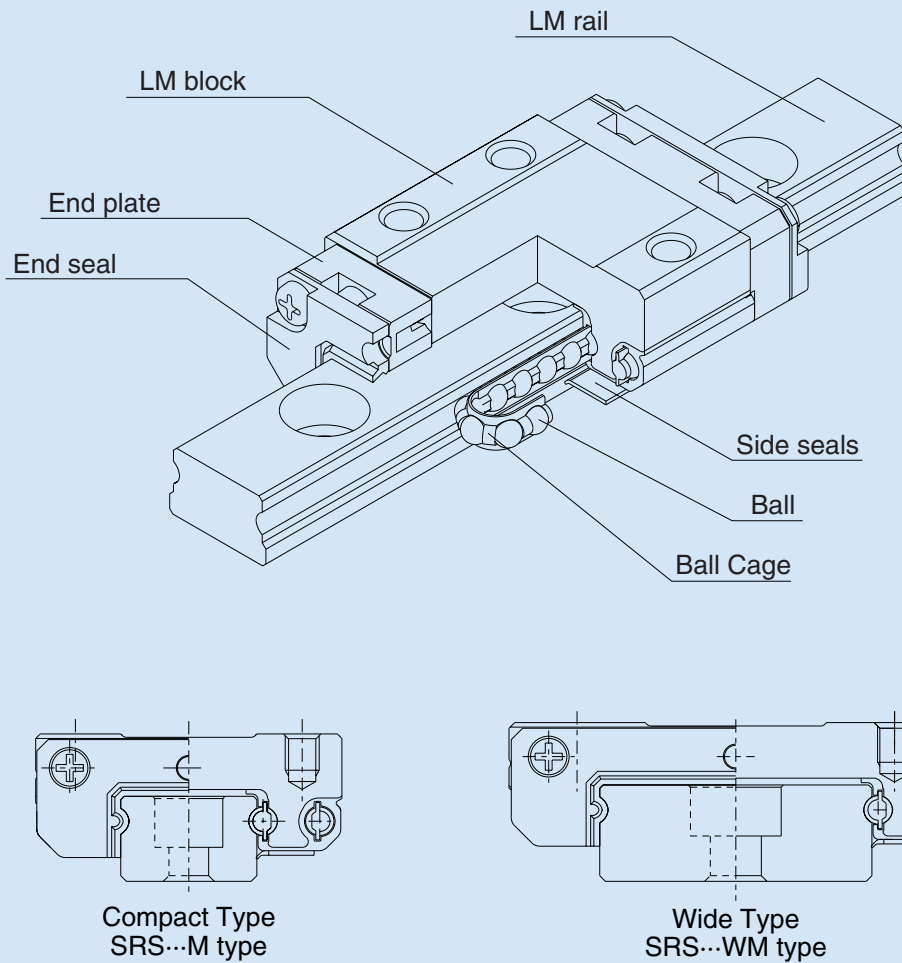
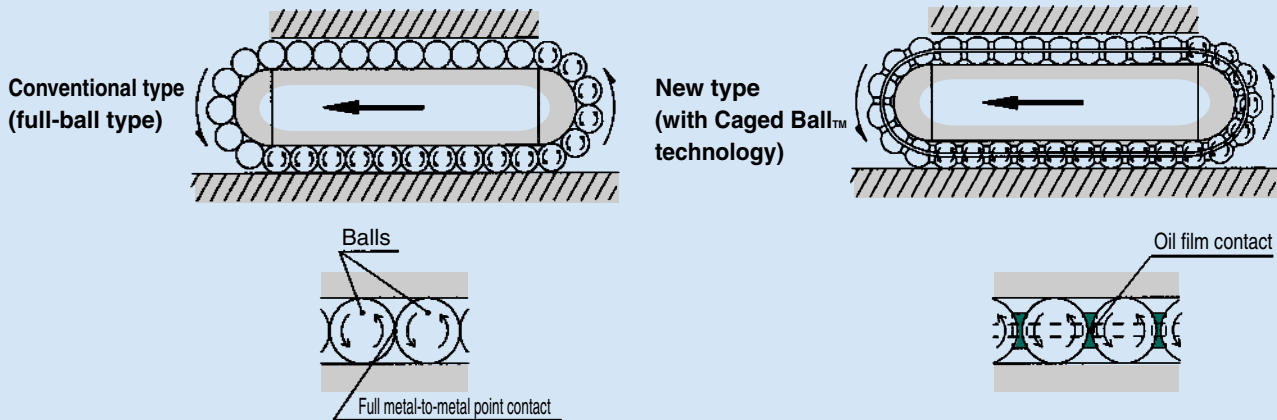

Figure 1 Expanded view of SRS Construction

**Caged Ball™ LM Guide Model SRS has a compact design that can accommodate two raceways, each of which bears loads in opposite directions. This design allows Caged Ball™ to be used on a single axis, in limited space, and in locations subject to moment load. Friction between balls is also reduced, resulting in quieter operation, long-term maintenance-free operation, low dust generation, and outstanding speed.**

## Friction Between Balls

### Linear motion (LM) guide



### Rotary ball bearing

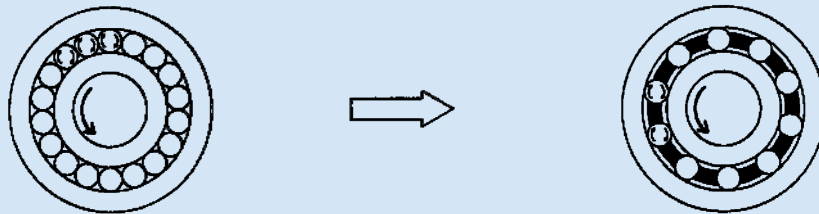

#### In the first stage of development (full-ball type)

- Because adjacent balls fully touch each other, contact stress is high and friction occurs due to breakdown of the oil film.
- The effective life of the bearing becomes shorter.

#### Present bearing (with Caged Ball™ technology)

- The absence of friction between adjacent balls extends the effective life of the bearing.
- Heat generation during high-speed rotation is limited due to the absence of friction between the balls.
- There is no noise of balls colliding since the balls do not touch each other.
- The balls move smoothly since they are spaced equally around the bearing.
- The lubricating oil is retained in the bearing, providing excellent lubrication and prolonging the life of the bearing.

The first rotary bearings developed did not have ball cages. They were noisy, could not operate at high speeds and had a short working life.

Twenty years later, rotary bearings with ball cages were developed, providing bearings that were quiet, could operate at high speeds and had a long service life despite the fact that they used fewer ball bearings. This constituted a major turning point in the development of rotary bearings.

The history of needle bearings also testifies to the huge improvement in bearing quality that resulted from the introduction of ball cages.

Where a ball cage is not used, there is direct metal-to-metal contact between the ball bearings. At this contact point, the surfaces are rotating in opposite directions, resulting in a contact speed that is twice the bearing rotation rate. This in turn results in high levels of friction and noise and a short operating life.

Normally, the oil film breaks down at a surface pressure of 3 kg/mm<sup>2</sup>. Where there is direct contact between the balls, the pressure between the ball surfaces is unlimited, causing the oil film to break down and resulting in metal-to-metal contact.

By contrast, balls in a retaining cage contact the cage over a large surface area. This prevents breakdown of the oil film and provides for quieter operation, higher rotation speeds and a longer operating life.

**At THK, we utilized our many years of experience along with innovative manufacturing techniques to develop the new Caged Ball™ Technology, and we have built this technology into the new generation of smooth-running LM guides. The main features of the new LM guides are as follows.**

### **Low noise**

Kept separate in the ball cage, the balls do not touch each other, so noise levels are low with none of the metallic clattering you hear from full-ball type bearings.

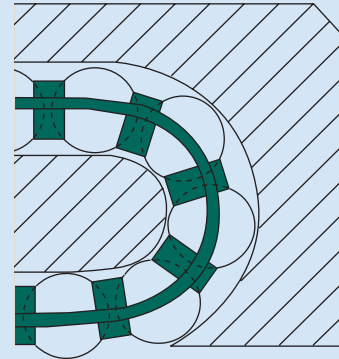

Figure 2

### **Long service life and long-term, maintenance-free operation**

Because the Caged Ball™ design practically eliminates resistance between balls, grease retention is increased. This eliminates most friction-related problems and provides maintenance-free service for many years to come.

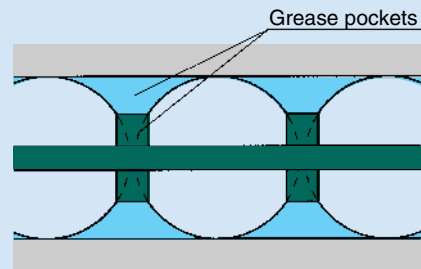

Figure 3

### **Excellent high-speed operation**

Because the Caged Ball™ design reduces ball-to-ball friction, surface pressure and heat generation are reduced by about half, thus increasing operating speed.

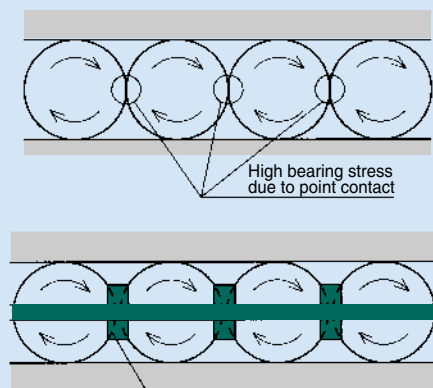

Figure 4

### **Super smooth movement**

The bearing moves smoothly with only minimal variation in resistance since the balls are spaced uniformly as the bearing moves around.

# **SRS Features**

## **Low dust generation**

The Caged Ball™ Technology used in SRS-type bearings eliminates friction between the balls and provides improved grease retention, minimizing dust generation. The use of stainless steel in the construction of the bearing also offers excellent rust prevention.

## **4-way equal load rating**

The SRS bearings can be used for different applications in any position because each row of balls is arranged at a 45° angle. Consequently, the same load rating is applied to the bearing in all four directions (radial, reverse radial and both lateral directions).

## **Compact**

The low cross-section height of the rail in SRS bearings and its compact design with a single row of balls allows them to be installed in very limited spaces.

## **Lightweight**

The SRS is a lightweight, low-inertia bearing made of resin formed using insertion molding in part of the LM block (eg. around the ball housing channel).

Since the effect of the ball cages eliminates friction between adjacent balls while also enhancing the retention of grease, the basic

Model no.	Basic dynamic load ratings C kN
SRS 9WM	3.29
SRS12WM	5.48
SRS15WM	9.12

Model no.	Basic dynamic load ratings C kN
RSR 9WV(M)	2.45
RSR12WV(M)	4.02
RSR15WV(M)	6.66

Comparison of Basic Dynamic Load Ratings between Caged Ball™ LM Guide Model SRS and Uncaged LM Guide Model RSR

## Rolling resistance data

Because SRS-type bearings use the Caged Ball™ technology, the balls are uniformly spaced along the ball cage and do not deviate from a straight path when they enter the block. This ensures that the balls move smoothly and stably regardless of the mounting position, thereby minimizing variations in rolling resistance.

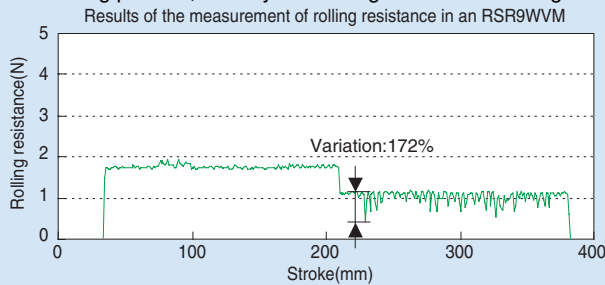

Figure 5 Results of the measurement of rolling resistance variation in an RSR9WVM (used upright) (feeding speed: 10 mm/sec)

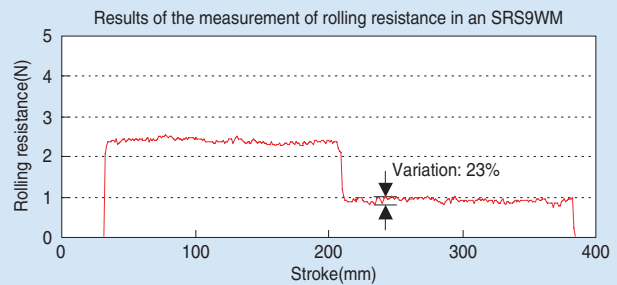

Figure 6 Results of the measurement of rolling resistance variation in an SRS9WM (used upright) (feeding speed: 10 mm/sec)

## Noise level data

The ball circulating components in SRS-type bearings are molded inside the block. This eliminates metallic noise caused by balls contacting the block. The use of Caged Ball™ technology also prevents contact between the balls themselves, allowing the bearing to operate quietly even at high speeds. This same technology also eliminates friction between the balls, reducing heat generation and providing superb performance in high-speed operation.

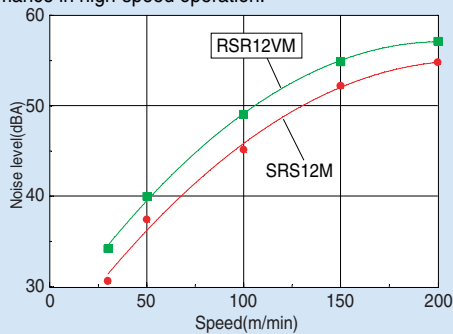

Figure 7 Comparison of noise levels in the SRS12M and RSR12VM

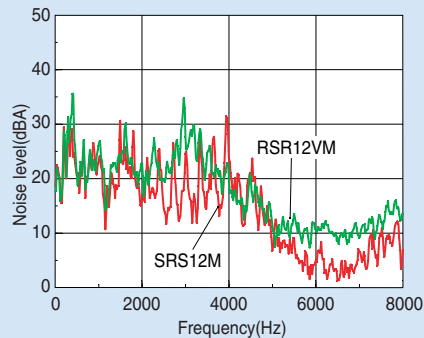

Figure 8 Comparison of noise levels in the SRS12M and RSR12VM (speed: 100 m/min)

## Dust generation data

Because SRS-type bearings use the Caged Ball™ technology, the lubricating oil is retained in the bearing and the construction generates only minimal dust dispersion, providing excellent low dust-generation properties.

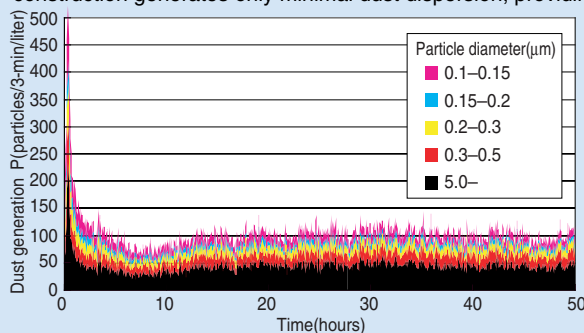

Figure 9 Results of RSR 15VM dust generation measurement (using AFF grease)

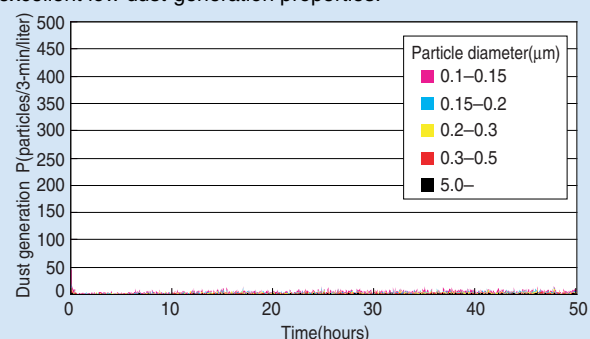
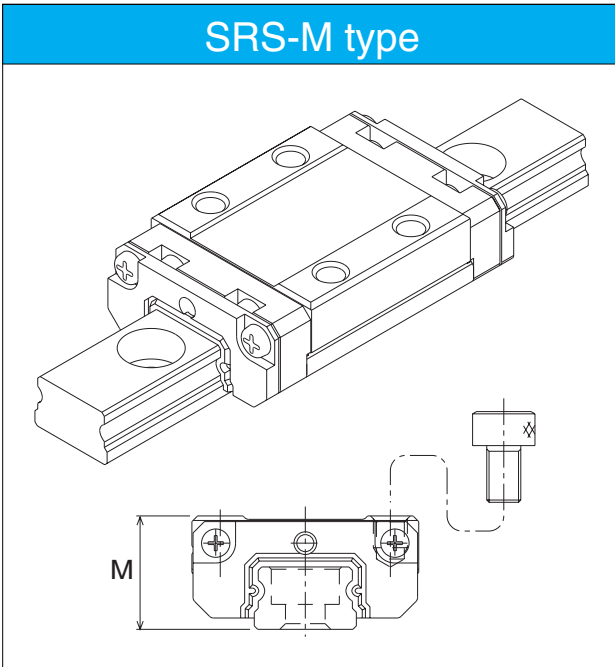

Figure 10 Results of SRS 15M dust generation measurement (using AFF grease)

## Types and features

### SRS-M type



Standard SRS type

### SRS-WM type

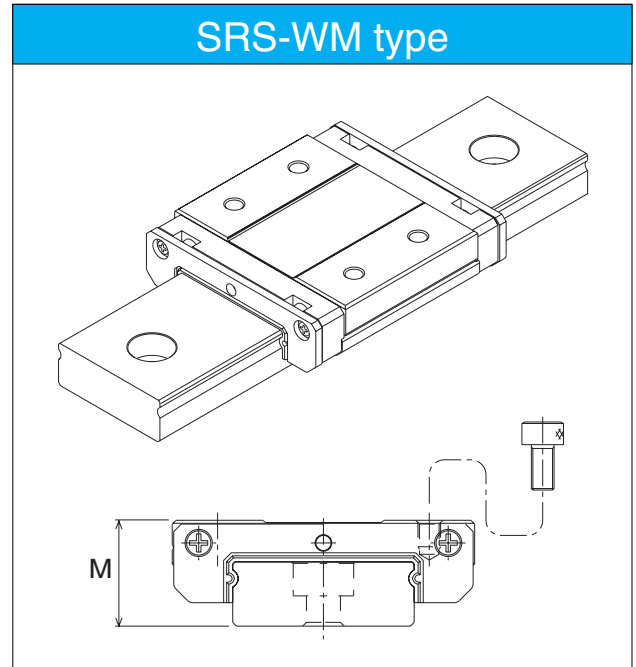

Overall LM block length of the standard type has been increased and the width has been reduced, thereby increasing rated load and permissible moment.

## Options

THK provides a wide range of options for SRS-type LM guides, as outlined below. Select the options best suited to your needs.

### Options

1. Seals
  - End seals
  - Side seals
2. Grease nipple (See P.8)
3. LM rail mounting hole caps (See P.8)
4. Lubricator QZ (only for SRS20 and 25)

## 1. Seals

### End seals

End seals are fitted to SRS-type LM guides as a standard feature.

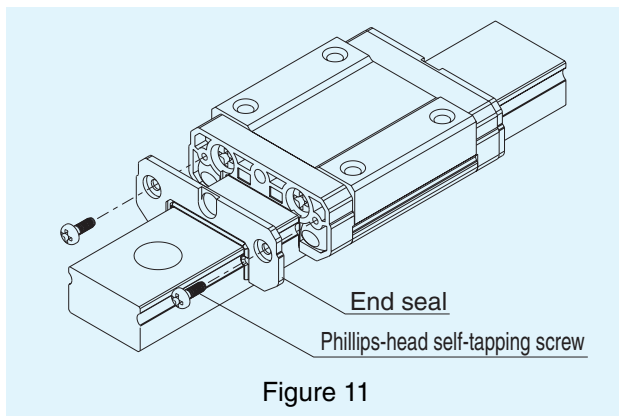

Figure 11

### Side seals

SRS-type LM guides are provided with side seals to prevent soiling from the underside of the LM block.

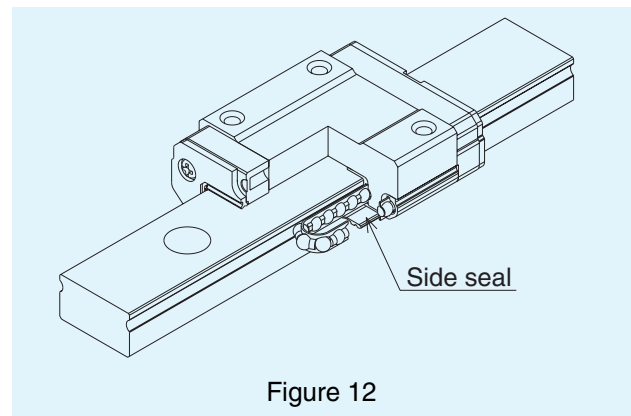

Figure 12

## Codes for contamination protection parts

When protection from contamination is required, use the codes shown below to specify the required parts.

The overall length of the block differs depending on the model. Please contact THK for details.

Table 1 Codes for contamination protection parts

Code	Optional part
UU	With end seals (both ends)
SS	With end seals and side seals



## 2. Grease nipple and oil hole

Because the standard specifications do not include a grease nipple and oil hole, you should select either the Lubricator QZ option\* or Contact scraper LaCS option\* when the guide is to be used in particularly harsh environments. If the guide still fails to run sufficiently smoothly with these options installed, select the grease nipple option.

Note that installing the grease nipple changes the total length of the block.

(See Table 2 for information on models that support grease nipples and the dimensions.)

- Note 1) The machining to install a grease nipple and oil hole cannot be performed on a standard specification model.
- Note 2) Only SRS20 and 25 are provided with the Lubricator QZ.  
Confirm that Lubricator QZ is not constructed to accept a grease nipple.
- Note 3) Contact  for more information on the Lubricator QZ and Contact scraper LaCS options.
- Note 4) SRS9, 9W, 12 and 12W are not provided

## 3. C cap for LM rail mounting holes

If dust or foreign matter enters an LM rail mounting hole on the LM guide, the contamination could also find its way into the inside of the block. This can be prevented by covering the mounting holes with the special caps provided and then ensuring that the caps are flush with the upper surface of the LM rail.

The C-type cap for LM rail mounting holes is made from a special synthetic resin that has excellent oil-proofing and wear-resistance properties, providing a high level of durability. The special caps are kept in stock as standard parts and can be ordered by specifying the model number listed in the table.

To insert a special cap into an LM rail mounting hole, lay a flat metal drift over the cap, as shown in Figure 14, and then gently tap the drift until the cap is flush with the top of the LM rail.

Table 3 Main dimensions of the special caps

Model No.	C cap No.	Applicable bolt	D (mm)	H (mm)
SRS 9M	—	—	—	—
SRS 9WM	C3	M3	6.3	1.2
SRS 12M	C3	M3	6.3	1.2
SRS 12WM	—	—	—	—
SRS 15M	C3	M3	6.3	1.2
SRS 15WM	—	—	—	—
SRS 20M	C5	M5	9.8	2.4
SRS 25M	C6	M6	11.4	2.7

Table 2 Grease nipple and oil hole dimensions Unit: mm

Model No.	E	N	Grease nipple and oil hole
SRS 9M	—	2.4	ø1.5 Drill hole
SRS 9WM	—	2.3	ø1.6 Drill hole
SRS 12M, 12WM	—	3.0	ø2.0 Drill hole
SRS 15M, 15WM	4.0	3.0	PB107
SRS 20M	3.6	4.0	PB107
SRS 25M	4.0	5.0	PB1021B

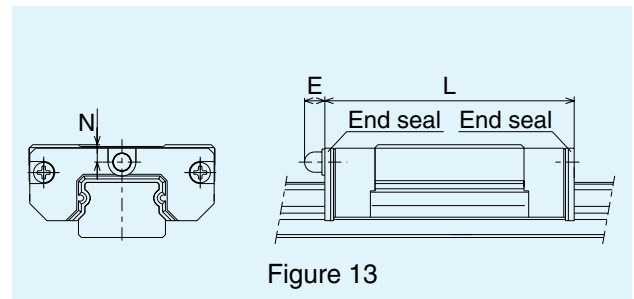

Figure 13

Note) See Table 3 or the dimensions tables for the length of dimension L.

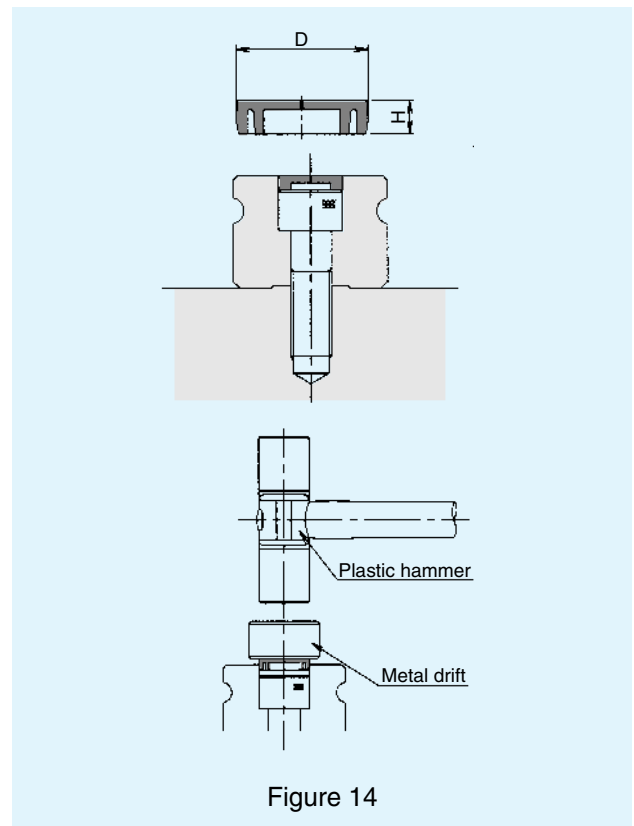
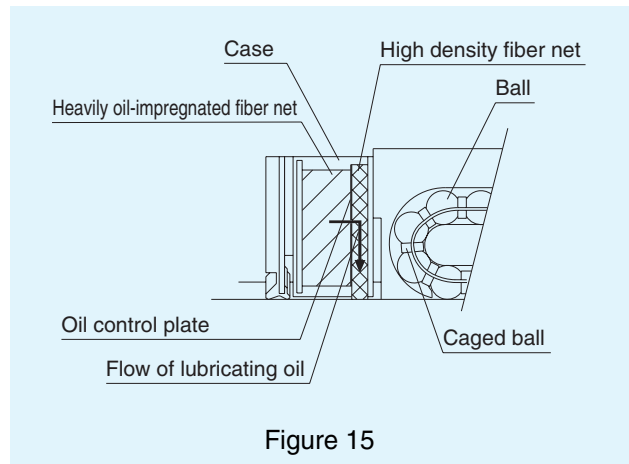

Figure 14

## 4. Lubricator QZ

THK has developed a lubricator QZ with a built-in fiber net of high oil content (absorbent) to eliminate the need for maintenance of the LM guide lubrication for a long term.

- **A substantial extension of maintenance intervals**  
Normal grease lubrication is accompanied by loss of a very small amount of oil in traveling. Installation of the lubricator QZ makes up for lost oil and allows a substantial extension of maintenance intervals.
- **Environment friendly lubrication system**  
The lubricator QZ uses a high density fiber net to supply a proper amount of oil to appropriate positions. This is an environment friendly lubrication system eliminating waste of oil.
- **Setting of oil to meet application requirements**  
The lubricator QZ allows you to set the oil to be sealed in conformity to application requirements of the LM guide. SRS has the lubricator QZ available for you as a standard option. For further information, see THK Catalog No.230.



## Load ratings and service life

THK SRS-type LM guides can support loads in the radial, reverse radial and lateral directions. The basic load ratings listed in the dimensions tables show the load ratings in the radial direction.

### Calculating the service life

Use the following equation to calculate the service life of a THK SRS-type LM guide.

$$L = \left( \frac{f_t \cdot f_c}{f_w} \cdot \frac{C}{P_c} \right)^3 \cdot 50$$

- L** : Rated service life (km)  
("Nominal service life" (L) refers to the average total distance traveled by 90% of a group of identical linear motion systems under identical conditions, without developing flaking.)
- C** : Basic dynamic load rating (N)  
(The "basic dynamic load rating" (C) refers to the load of a group of identical linear motion systems under identical conditions (including direction and magnitude) such that the nominal service life (L) of the systems is 50 km (L = 50 km).)
- P<sub>c</sub>** : Design load (N)
- f<sub>t</sub>** : Temperature coefficient  
(See general catalog P.A-88, Fig. 38.)
- f<sub>c</sub>** : Contact coefficient  
(See general catalog P.A-89, Table 12.)
- f<sub>w</sub>** : Load factor  
(See general catalog P.A-89, Table 13.)

Given a rated service life (L) as calculated using the above equation and assuming that the stroke length and reciprocation rate are constant, the length of the service life can be calculated using the following

$$L_h = \frac{L \times 10^6}{2 \times \ell_s \times n_1 \times 60}$$

- L<sub>h</sub>** : Length of service life (hours)
- ℓ<sub>s</sub>** : Stroke length (mm)
- n<sub>1</sub>** : Number of reciprocating motions per minute (min<sup>-1</sup>)

## Load ratings and permissible moment in each direction

### Load ratings

THK SRS-type LM guides can support loads in the radial, reverse radial and lateral directions. The basic load ratings listed in the dimensions tables show the load ratings in the radial direction in the figure. The load ratings in the reverse radial and lateral directions can be estimated from Table 1.

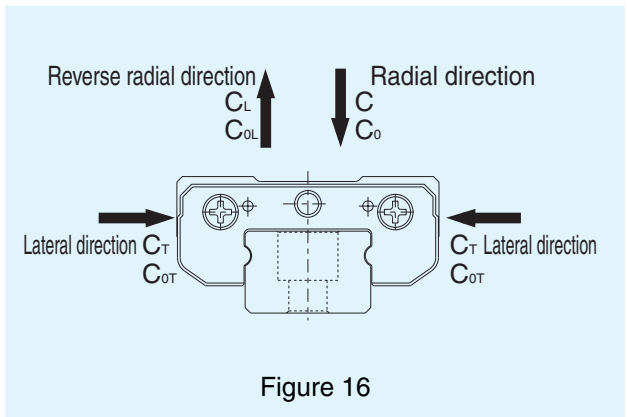

Figure 16

Table 4 Basic load ratings in each direction for SRS-type LM guides

Direction	SRS Type	
	Basic dynamic load rating	Basic static load rating
Radial	C	C <sub>0</sub>
Reverse radial	C <sub>L</sub> =C	C <sub>0L</sub> =C <sub>0</sub>
Lateral (9, 9W, 20)	C <sub>T</sub> =1.19C	C <sub>0T</sub> =1.19C <sub>0</sub>
Lateral (12, 12W, 15, 15W, 25)	C <sub>T</sub> =C	C <sub>0T</sub> =C <sub>0</sub>

### Equivalent load

When an SRS-type LM block is subjected to simultaneous loading from the radial and lateral directions or from the reverse-radial and lateral directions, the equivalent load can be calculated using the following equation.

$$P_E = X \cdot P_R (P_L) + Y \cdot P_T$$

**P<sub>E</sub>** : Equivalent load (N)  
• Radial  
• Reverse radial  
• Lateral

**P<sub>R</sub>** : Radial load (N)

**P<sub>L</sub>** : Reverse radial load (N)

**P<sub>T</sub>** : Lateral load (N)

X, Y: Equivalence coefficient (Table 5)

Table 5 Equivalence coefficients for the SRS type

P <sub>E</sub>	Model No.	X	Y
Radial and reverse radial equivalent load	9, 9W, 20	1	0.839
	12, 12W, 15, 15W, 25	1	1
Lateral equivalent load	9, 9W, 20	1.192	1
	12, 12W, 15, 15W, 25	1	1

## Notes on use

### Installation surface shoulder heights and bottom corners

Table 6 lists the recommended shoulder heights for installing the LM block and LM rail. To prevent corner bevelling or interference between the LM block and LM rail, the corner of the installation surface should have some clearance or should be machined to a radius equal to or less than  $r$  in Table 6.

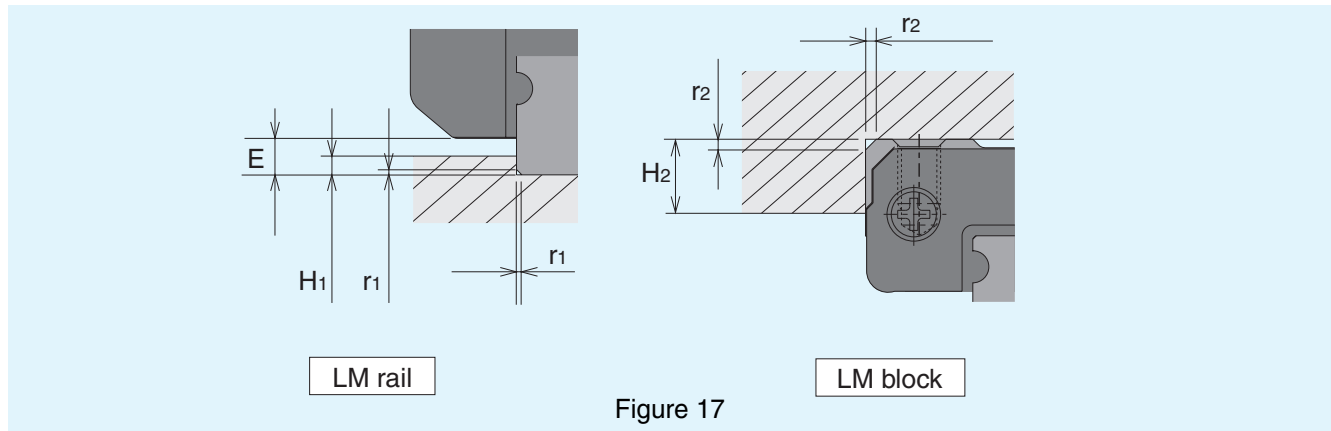

Table 6 Installation surface shoulder height and corner radius

Unit: mm

Model No.	LM rail corner radius $r_1$ (max.)	LM block corner radius $r_2$ (max.)	LM rail shoulder height $H_1$	LM block shoulder height $H_2$	E
SRS 9M	0.1	0.3	0.5	4.9	0.9
SRS 9WM	0.1	0.5	2.5	4.9	2.9
SRS 12M	0.3	0.2	1.5	5.7	2.0
SRS 12WM	0.3	0.3	2.5	5.7	3.0
SRS 15M	0.3	0.4	2.2	6.5	2.7
SRS 15WM	0.3	0.3	2.2	6.5	2.7
SRS 20M	0.3	0.5	3.0	8.7	3.4
SRS 25M	0.5	0.5	4.5	10.5	5.0

## Seal resistance

Table 7 shows the maximum values for seal resistance in 1 LM block when lubricant is applied to an SRS-type LM guide with seals (SS-type).

Table 7 Seal resistance (SS-type)

Unit: N

Model No.	Resistance
SRS 9M	0.2
SRS 9WM	1.0
SRS 12M	0.6
SRS 12WM	1.3
SRS 15M	1.0
SRS 15WM	1.6
SRS 20M	1.3
SRS 25M	1.6

## Flatness of LM rail and LM block installation surfaces

The values shown in Table 8 can be used as the normal clearance. When C1 is used with 2 rails, the value shown in the table should be halved.

Table 8 Flatness of LM rail and LM block installation surfaces  
Unit: mm

Model No.	Flatness
SRS 9M	0.035/200
SRS 9WM	0.035/200
SRS 12M	0.050/200
SRS 12WM	0.050/200
SRS 15M	0.060/200
SRS 15WM	0.060/200
SRS 20M	0.070/200
SRS 25M	0.070/200

## Precision Standards

Table 9 shows the precision standards for the SRS. The precision is shown in terms of the parallelism for an LM guide running the length of the LM rail shown in Figure 18.

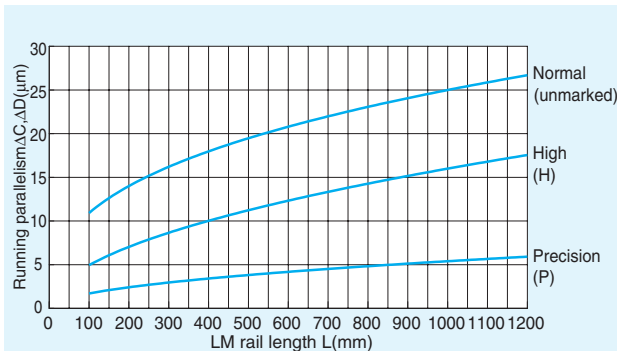

Figure 18 LM rail length and the running parallelism

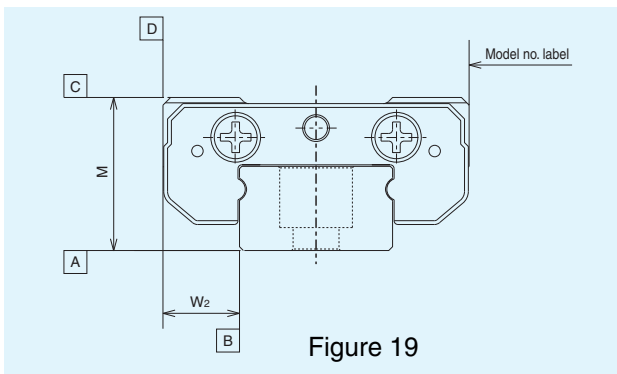

Figure 19

Table 9 SRS-type precision standards

Unit: mm

Model No.	Precision standard	Normal	High	Precision
	Item	Unmarked	H	P
SRS	Tolerance of height M	±0.04	±0.02	±0.01
	Difference in height M	0.03	0.015	0.007
	Tolerance of width W <sub>2</sub>	±0.04	±0.025	±0.015
	Difference in width W <sub>2</sub>	0.03	0.02	0.01
	Running parallelism of flat C with respect to flat A	ΔC (see Fig. 18)		
	Running parallelism of flat D with respect to flat B	ΔD (see Fig. 18)		

## Radial clearance

Table 10 shows the radial clearances for SRS-type LM guides.

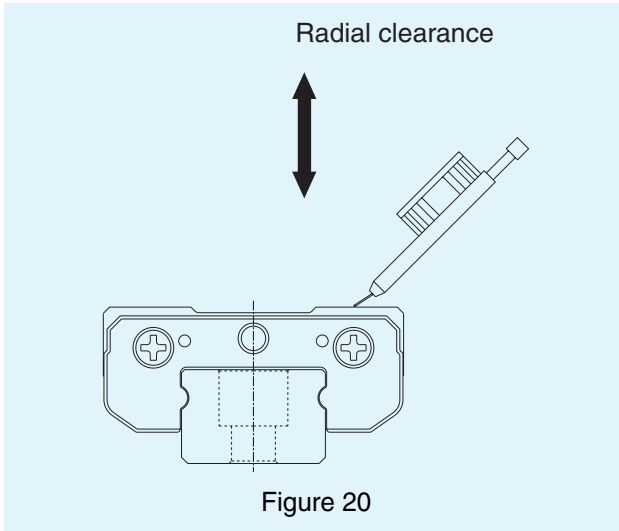
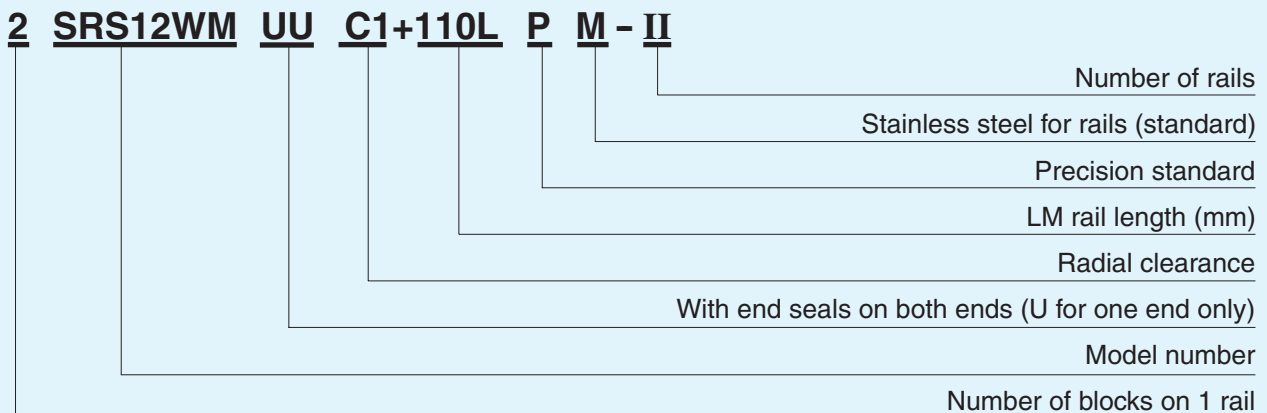
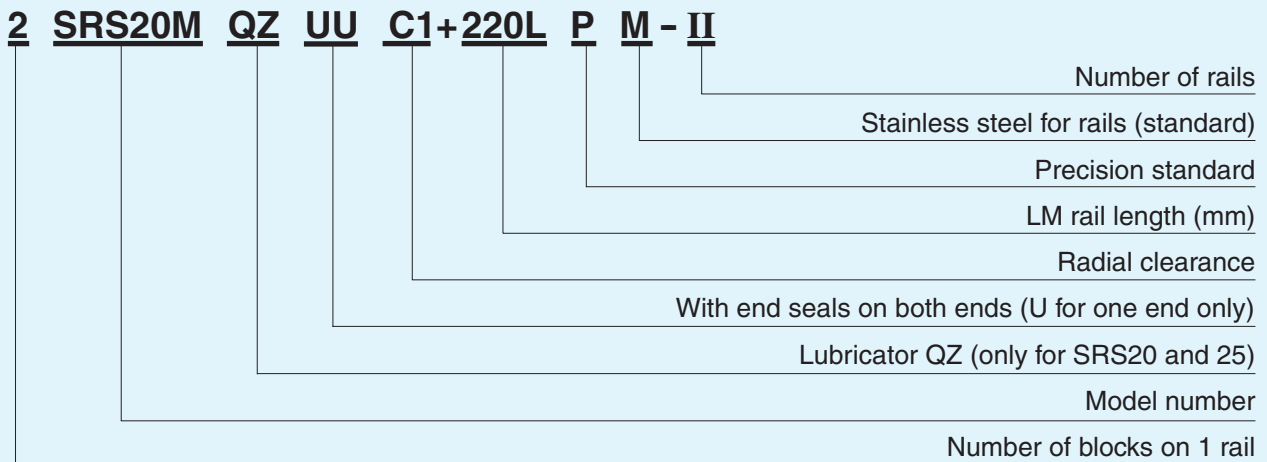

Table 10 Radial clearances for SRS-type LM guides  
Unit:  $\mu\text{m}$

Model No.	Unmarked	C1
SRS 9M, 9WM	-2~+2	-4~0
SRS 12M, 12WM	-3~+3	-6~0
SRS 15M, 15WM	-5~+5	-10~0
SRS 20M	-5~+5	-10~0
SRS 25M	-7~+7	-14~0

## Model number coding



- Notes)
- This model number applies to 1 set on 1 rail unit. (At least 2 sets are required when used on 2 parallel rails.)
  - For installation of a grease nipple, specify "with grease nipple"(for SRS15, 15W, 20 and 25).
  - If you want to use the oil hole, specify "Oil Hole" (for SRS9, 9W, 12 and 12W).

## Standard and maximum LM rail lengths

Table 11 shows the standard and maximum LM rail lengths for the SRS-type LM guides. If the rail length exceeds the maximum length, the rail will be manufactured in 2 or more sections.

If a special length is required, the G dimension given in the table should be used. If the G dimension is too

long, the ends of the rail tend to become unstable after installation, which adversely affects precision.

When 2 or more rail sections are to be connected, you must specify the total length required so that THK can manufacture the sections using simultaneous machining to ensure that the joints are smooth.

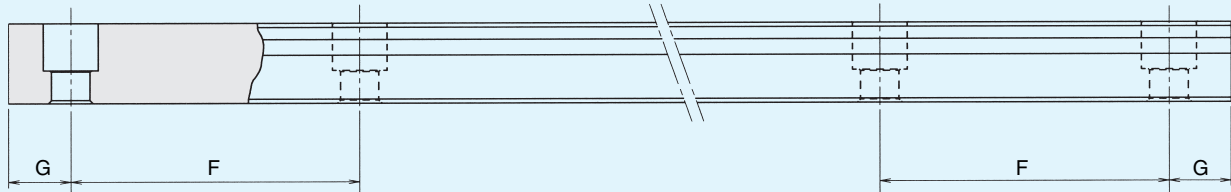

Figure 21

Table 11 Standard and maximum LM rail lengths for SRS-type LM rails

Unit: mm

Model No.	SRS 9M	SRS 9WM	SRS 12M	SRS 12WM	SRS 15M	SRS 15WM	SRS 20M	SRS 25M	
LM rail standard length	55	50	70	70	70	110	220	220	
	75	80	95	110	110	150	280	280	
	95	110	120	150	150	190	340	340	
	115	140	145	190	190	230	460	460	
	135	170	170	230	230	270	640	640	
	155	200	195	270	270	310	880	880	
	175	260	220	310	310	430	1000	1000	
	195	290	245	390	350	550			
	275	320	270	470	390	670			
	375		320	550	430	790			
			370		470				
			470		550				
		570		670					
				870					
Standard pitch F	20	30	25	40	40	40	60	60	
G	7.5	10	10	15	15	15	20	20	
Maximum length	1000	1000	1340	1430	1430	1800	1800	1800	

# Compact Type

## Type SRS-M

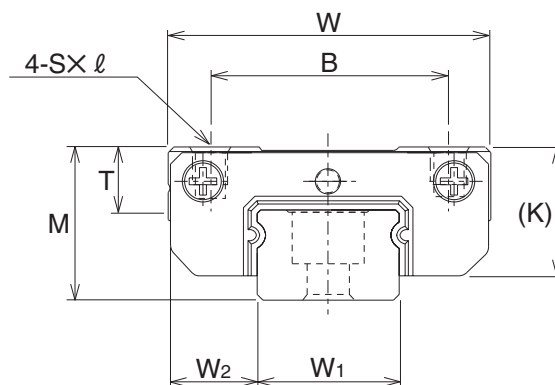

Model No.	External dimensions			LM block dimensions					
	Height M	Width W	Length L	B	C	SX l	L <sub>1</sub>	T	K
SRS 9M	10	20	30.8	15	10	M3X2.8	19.8	4.9	9.1
SRS 12M	13	27	34.4	20	15	M3X3.2	20.6	5.7	11.0
SRS 15M	16	32	43.0	25	20	M3X3.5	25.7	6.5	13.3
SRS 20M	20	40	50.0	30	25	M4X6	34.0	9.1	16.6
SRS 25M	25	48	77.0	35	35	M6X7	56.0	11.0	20.0

- Notes)
- The machining to install a Grease nipple and oil hole cannot be performed on a standard specification model. (See P.8 for details.)
  - See P.13 for a breakdown of the model number coding.
  - See P.14 for information on LM rail lengths.
  - The M coding indicates that stainless steel is used for the LM block, LM rail and the ball bearings, providing excellent resistance to corrosion and the capacity to operate in a wide range of environments.



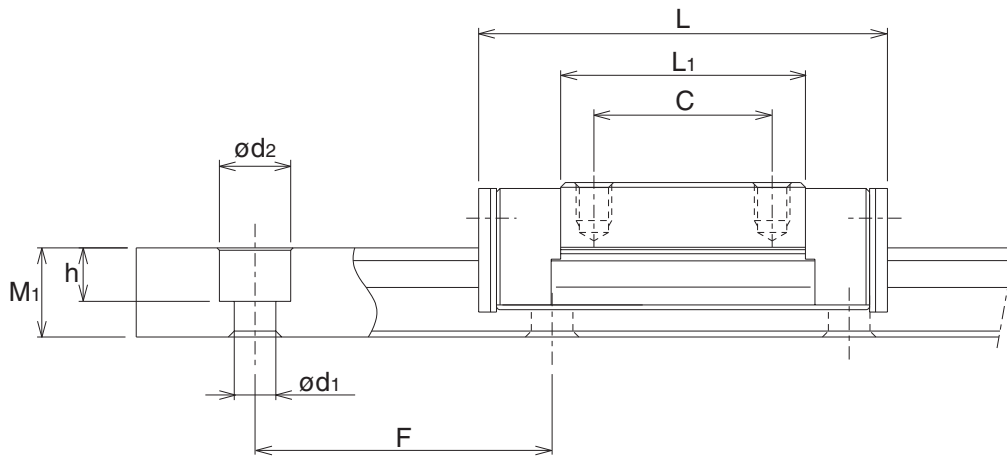

Unit: mm

LM rail dimensions					Basic load rating		Permissible static moment			Mass	
Width $W_1$	$W_2$	Height $M_1$	Pitch $F$	$d_1 \times d_2 \times h$	$C$ kN	$C_0$ kN	$MA$ N·m	$MB$ N·m	$MC$ N·m	LM block kg/block	LM rail kg/m
9 <sup>0</sup> <sub>-0.02</sub>	5.5	5.5	20	3.5×6×3.3	2.69	2.31	7.0	8.3	10.6	0.016	0.32
12 <sup>0</sup> <sub>-0.02</sub>	7.5	7.5	25	3.5×6×4.5	4.00	3.53	12.1	12.1	23.1	0.027	0.65
15 <sup>0</sup> <sub>-0.02</sub>	8.5	9.5	40	3.5×6×4.5	6.66	5.70	24.7	24.7	40.4	0.047	0.96
20 <sup>0</sup> <sub>-0.03</sub>	10.0	11.0	60	6×9.5×8	7.75	9.77	58.7	69.9	104.5	0.11	1.68
23 <sup>0</sup> <sub>-0.03</sub>	12.5	15.0	60	7×11×9	16.5	20.2	180.0	180.0	248.0	0.24	2.6

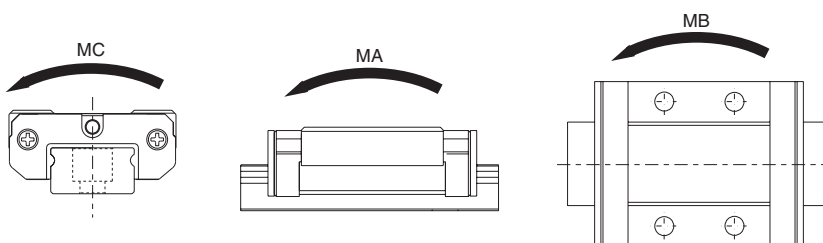

# Wide Type

## Type SRS-WM

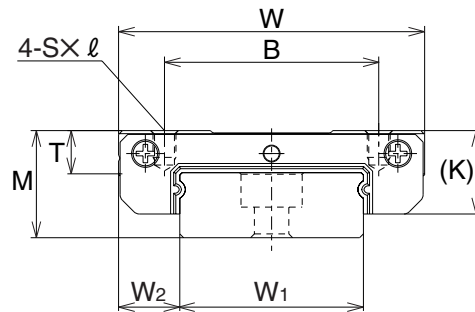

SRS 9W, 12WM

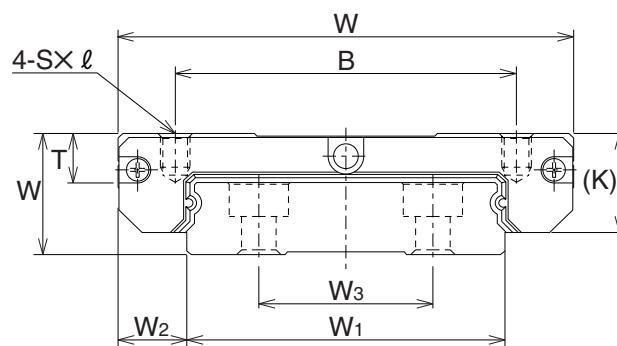

SRS 15WM

Model No.	External dimensions			LM block dimensions					
	Height M	Width W	Length L	B	C	SX ℓ	L <sub>1</sub>	T	K
SRS 9WM	12	30	39.0	21	12	M3X2.8	27.0	4.9	9.1
SRS 12WM	14	40	44.5	28	15	M3X3.5	30.9	5.7	11.0
SRS 15WM	16	60	55.5	45	20	M4X4.5	38.9	6.5	13.3

- Notes)
- The machining to install a Grease nipple and oil hole cannot be performed on a standard specification model. (See P.8 for details.)
  - See P.13 for a breakdown of the model number coding.
  - See P.14 for information on LM rail lengths.
  - The M coding indicates that stainless steel is used for the LM block, LM rail and the ball bearings, providing excellent resistance to corrosion and the capacity to operate in a wide range of environments.

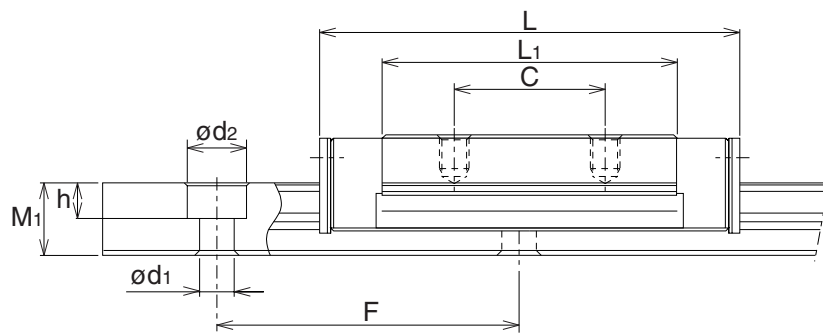

Unit: mm

LM rail dimensions						Basic load rating		Permissible static moment			Mass	
Width $W_1$	$W_2$	$W_3$	Height $M_1$	Pitch $F$	$d_1 \times d_2 \times h$	C kN	$C_0$ kN	MA N·m	MB N·m	MC N·m	LM block kg/block	LM rail kg/m
18 <sup>0</sup> <sub>-0.02</sub>	6.0	—	7.5	30	3.5×6×4.5	3.29	3.34	13.8	16.5	31.5	0.031	1.01
24 <sup>0</sup> <sub>-0.02</sub>	8.0	—	8.5	40	4.5×8×4.5	5.48	5.30	25.1	25.1	66.5	0.055	1.52
42 <sup>0</sup> <sub>-0.02</sub>	9.0	23	9.5	40	4.5×8×4.5	9.12	8.55	51.5	51.5	177.0	0.13	2.87

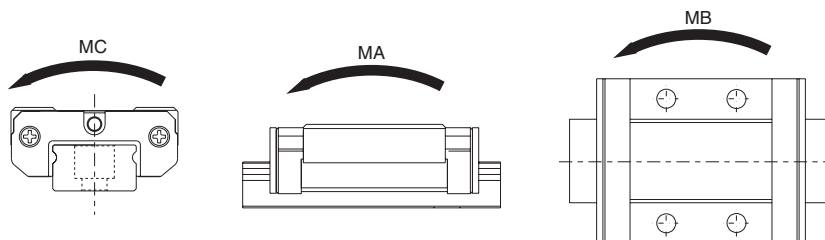

## SRS

### ⚠ Notes on use

#### \*Precautions when handling the LM block

The LM block contains precision-molded resin components. Take great care when handling the block since dropping or striking the block could damage it.

#### \*Reinstalling the LM block

Insertion jigs are available to ensure easy mounting when you want to mount the LM block again after removing it from the LM rail. For further information, contact THK.

#### \*Coolant

If this product is to be used in an environment where coolant may get into the LM block, contact THK, as some types of coolant can impair the functioning of the LM block.

#### \*Installation surface precision

Because the SRS-type LM guides use indentations with a pointed (gothic) arch shape, any discrepancy in the installation surface precision can adversely affect the operation of the product. The guide should be installed on a high-precision installation surface.

#### \*Operating temperature range

Do not use the LM block in temperatures above 80°C as it uses a special resin.

#### \*Lubrication

In some cases, it may not be possible to use ordinary grease when this product is used in special environments such as an area subject to extremes of temperature or vibration, a clean room, or in a vacuum. If this product is to be used in such an environment, contact THK.

#### \*Using the grease nipple socket

When the grease nipple socket in the LM block is to be used, the nipple is installed by THK. (To prevent the entry of foreign matter, the hole is not drilled through.) Note also that the nipple socket is designed specifically for grease nipple installation and should not be used for any other purpose as this could damage the socket.

\*All rights reserved.

\*Specifications are subject to change without notice.

## THK THK CO., LTD.

HEAD OFFICE 3-11-6, NISHI-GOTANDA, SHINAGAWA-KU, TOKYO 141-8503 JAPAN  
INTERNATIONAL SALES DEPARTMENT PHONE:(03)5434-0351 FAX:(03)5434-0353

#### U. S. A.

CHICAGO  
PHONE:(847)310-1111 FAX:(847)310-1182  
NEW JERSEY  
PHONE:(201)529-1950 FAX:(201)529-1962  
LOS ANGELES  
PHONE:(714)891-6752 FAX:(714)894-9315  
SAN FRANCISCO  
PHONE:(925)455-8948 FAX:(925)455-8965  
ATLANTA  
PHONE:(770)840-7990 FAX:(770)840-7897  
DETROIT  
PHONE:(248)858-9330 FAX:(248)858-9445  
BOSTON  
PHONE:(781)575-1151 FAX:(781)575-9295  
INDIANAPOLIS  
PHONE:(317)243-3494 FAX:(317)243-3499  
MINNEAPOLIS  
PHONE:(612)953-4442 FAX:(612)953-4441  
CANADA (MISSISSAUGA,ONT)  
PHONE:(905)712-2922 FAX:(905)712-2925  
BRASIL (SÃO PAULO)  
PHONE:(011)3924-0911 FAX:(011)3924-0900

#### GERMANY

DÜSSELDORF  
PHONE:(02102)74250 FAX:(02102)7425299  
STUTTGART  
PHONE:(07141)2757-0 FAX:(07141)2757-90  
U.K. (MILTON KEYNES)  
PHONE:(01908)222159 FAX:(01908)222161  
FRANCE (LYON)  
PHONE:(0437)49.14.00 FAX:(0437)49.14.01  
ITALY (MILAN)  
PHONE:(039)2842079 FAX:(039)2842527  
SWEDEN (STOCKHOLM)  
PHONE:(08)4457630 FAX:(08)4457639  
AUSTRIA (LINZ)  
PHONE:(07229)51400 FAX:(07229)51400-79  
SPAIN (BARCELONA)  
PHONE:(093)652-5740 FAX:(093)652-5746  
PGM BALLSCREWS LIMITED (COVENTRY)  
PHONE:(02476)841900 FAX:(02476)611032  
PGM BALLSCREWS IRELAND LIMITED (DUBLIN)  
PHONE:(01)4628101 FAX:(01)4629080

#### TAIWAN

TAIPEI  
PHONE:(02)2585-8554 FAX:(02)2585-8495  
TAICHUNG  
PHONE:(04)2359-1505 FAX:(04)2359-1506  
CHINA  
BEIJING  
PHONE:(10)6590-3557 FAX:(10)6590-3557  
HONG KONG  
PHONE:2376-1091, 2376-1252 FAX:2376-0749  
MALAYSIA (KUALA LUMPUR)  
PHONE:(03)9287-1137 FAX:(03)9287-8071  
INDIA (BANGALORE)  
PHONE:(080)330-1524 FAX:(080)330-1524  
KOREA (SEOUL)  
PHONE:(02)3463-0351 FAX:(02)3017-0351

